

ABB INDUSTRIAL DRIVES

ACS880-104 inverter modules

Hardware manual



ACS880-104 inverter modules

Hardware manual

Table of contents



4. Cabinet construction



5. Electrical installation



9. Start-up



Table of contents

1 Introduction to the manual

Contents of this chapter.....	19
Applicability.....	19
Safety instructions.....	19
Target audience.....	19
Categorization by frame size and option code.....	20
Use of component designations.....	20
Terms and abbreviations.....	20
Related documents.....	21

2 Hardware description

Contents of this chapter.....	23
Overview diagram of the drive system.....	24
Inverter module hardware.....	25
General.....	25
Frames R1i...R4i.....	25
General.....	25
DC connection and capacitor charging.....	25
Frame R1i layout.....	27
Frame R4i layout.....	28
Overview circuit diagram of an inverter cubicle (frames R1i...R4i).....	29
Cabinet layout and cooling.....	29
Frame R5i.....	30
General.....	30
DC connection and capacitor charging.....	30
Frame R5i layout.....	31
Overview circuit diagram of an inverter cubicle (frame R5i).....	32
Cabinet layout and cooling.....	32
Frames R6i and R7i.....	33
General.....	33
DC connection and capacitor charging.....	33
Frame R6i and R7i layout (without option +C249).....	35
Frame R6i and R7i layout (options +V992 and +C249).....	36
Overview circuit diagram of an inverter cubicle (frame R6i).....	38
Overview circuit diagram of an inverter cubicle (frame R7i).....	39
Cabinet layout and cooling.....	39
Frame R8i and multiples.....	40
General.....	40
DC connection and capacitor charging.....	40
Frame R8i layout.....	42
Connectors X50...X53.....	43
Fiber-optic connectors.....	44
Overview circuit diagram of a frame R8i inverter unit.....	45
Overview circuit diagram of a frame 2×R8i inverter unit.....	46
Cabinet layout and cooling.....	46
Module variant with capability for increased switching frequency.....	47



Inverter unit control interfaces..... 47
 Overview of the control connections of the UCU-22, UCU-23 and UCU-24 control unit..... 48
 Overview of control connections of the ZCU control unit..... 49
 Overview of the control connections of the BCU control unit..... 50
 Control panel..... 51
 Control by PC tools..... 51
 Type designation key..... 52

3 Moving and unpacking the module

Contents of this chapter..... 53
 Moving and lifting the transport package..... 53
 Unpacking..... 53
 Frames R1i...R5i..... 53
 Frames R6i...R8i..... 53
 Lifting the unpacked modules..... 54
 Moving the unpacked modules..... 54

4 Cabinet construction

Contents of this chapter..... 55
 Limitation of liability..... 55
 North America..... 55
 General..... 55
 Configuration overviews of the inverter module cubicles..... 55
 Frame sizes R1i...R7i..... 56
 Frame sizes R8i and multiples, IEC installations in generic cabinets..... 57
 Frame sizes R8i and multiples, IEC and UL installations in VX25 Rittal cabinets.. 58
 Installation examples..... 60
 R1i...R4i modules in a 400 mm wide Rittal VX25 enclosure..... 62
 Installation stages..... 63
 Overview of kits..... 64
 Stage 1: Installation of common parts..... 65
 Stage 2: Installation of bottom plate..... 66
 Stage 3: Installation of mounting plate..... 67
 Stage 4: Installation of DC busbars..... 68
 Stage 5: Installation of mounting plate shrouds..... 69
 Stage 6: Installation of inverter modules and air guides..... 70
 Stage 7: Installation of du/dt filters..... 71
 R1i...R4i modules in a 600 mm wide Rittal VX25 enclosure..... 72
 Installation stages..... 73
 Overview of kits..... 74
 Stage 1: Instalation of common parts..... 75
 Stage 2: Installation of bottom plate..... 76
 Stage 3: Installation of mounting plate..... 77
 Stage 4: Installation of DC busbars..... 78
 Stage 5: Installation of mounting plate shrouds..... 79
 Stage 6: Installation of inverter modules and air guides..... 80
 Stage 7: Installation of du/dt filter..... 81
 R1i...R4i modules in a 800 mm wide Rittal VX25 enclosure..... 82
 Installation stages..... 83
 Overview of kits..... 84



Stage 1: Installation of common parts.....	85
Stage 2: Installation of bottom plate.....	86
Stage 3: Installation of mounting plate.....	87
Stage 4: Installation of DC busbars.....	88
Stage 5: Installation of mounting plate shrouds.....	89
Stage 6: Installation of inverter modules and air guides.....	90
Stage 7: Installation of du/dt filters.....	91
R5i modules in a 400 mm wide Rittal VX25 enclosure.....	92
Installation stages.....	93
Overview of kits.....	94
Stage 1: Installation of common parts.....	95
Stage 2: Installation of bottom plate.....	96
Stage 3: Installation of inverter module mounting plate.....	97
Stage 4: Installation of DC busbars.....	98
Stage 5: Installation of front mounting plate.....	99
Stage 6: Installation of inverter modules.....	100
Stage 7: Installation of du/dt filters.....	101
R5i modules in a 600 mm wide Rittal VX25 enclosure.....	102
Installation stages.....	103
Overview of kits.....	104
Stage 1: Installation of common parts.....	105
Stage 2: Installation of bottom plate.....	106
Stage 3: Installation of inverter module mounting plate.....	107
Stage 4: Installation of DC busbars.....	108
Stage 5: Installation of front mounting plate.....	109
Stage 6: Installation of inverter modules.....	110
Stage 7: Installation of du/dt filters.....	111
One R6i/R7i module in a 400 mm wide Rittal VX25 enclosure.....	112
Installation stages.....	113
Overview of kits.....	114
Stage 1: Installation of common parts.....	115
Stage 2: Installation of bottom plate.....	116
Stage 3: Installation of support beams.....	117
Stage 4 (R6i): Installation of DC busbars and charging components.....	118
Stage 4 (R7i): Installation of DC busbars and charging components.....	119
Stage 5: Installation of common mode filters.....	120
Stage 6 A: Installation of AC busbars (without du/dt filters).....	121
Stage 6 B: Installation of AC busbars (with du/dt filters).....	122
Stage 7: Installation of inverter module.....	123
Stage 8: Installation of shrouding brackets.....	124
One R6i/R7i module in a 400 mm wide generic enclosure.....	125
One R8i module in a 400 mm wide Rittal VX25 enclosure.....	127
Installation stages.....	128
Overview of kits.....	129
Stage 1: Installation of common parts.....	130
Stage 2 A: Installation of DC busbars (1) (without DC switch/charging).....	131
Stage 2 B: Installation of DC busbars (1) (with DC switch/charging).....	132
Stage 3: Installation of module installation parts and lead-throughs.....	133
Stage 4 A: Installation of quick connector and output (AC) busbars (cable connection).....	134
Stage 4 B: Installation of quick connector and output (AC) busbars (common AC output busbar connection).....	135



Stage 5 A: Installation of DC busbars (2) (without DC switch/charging).....136

Stage 5 B: Installation of DC busbars (2) (with DC switch/charging).....137

Stage 6: Installation of shrouding.....138

Stage 7: Installation of inverter module.....139

Two R8i modules in a 600 mm wide Rittal VX25 enclosure.....140

Installation stages.....141

Overview of kits.....143

Stage 1: Installation of common parts.....144

Stage 2 A: Installation of DC busbars (1) (without DC switch/charging).....145

Stage 2 B: Installation of DC busbars (1) (with DC switch/charging).....146

Stage 3: Installation of module installation parts and lead-throughs.....147

Stage 4 A: Installation of quick connector and output (AC) busbars (cable connection).....148

Stage 4 B: Installation of quick connector and output (AC) busbars (cable connection with bridging).....149

Stage 4 C: Installation of quick connector and output (AC) busbars (common AC output busbar connection).....150

Stage 5 A: Installation of DC busbars (2) (without DC switch/charging).....151

Stage 5 B: Installation of DC busbars (2) (with DC switch/charging).....152

Stage 6: Installation of shrouding.....153

Stage 7: Installation of inverter modules.....154

One R8i module in a 400 mm wide generic enclosure.....155

Two R8i modules in a 600 mm wide generic enclosure.....157

Three R8i modules in a 800 mm wide generic enclosure.....159

One BLHF filter in a 600 mm wide Rittal VX25 enclosure.....161

Installation stages.....162

Overview of kits.....163

Stage 1: Installation of common parts.....164

Stage 2: Installation of module installation parts.....165

Stage 3: Installation of AC busbars and AC input busbars.....166

Stage 4: Installation of filter module, AC flanges and shrouds.....167

Two BLHF filters in a 800 mm wide Rittal VX25 enclosure.....168

Installation stages.....169

Overview of kits.....170

Stage 1: Installation of common parts.....171

Stage 2: Installation of module installation parts.....172

Stage 3: Installation of AC busbars.....173

Stage 4: Installation of filter module, AC connection busbars and shrouds...174

One BLHF filter in a 600 mm wide generic enclosure.....175

Two BLHF filters in a 800 mm wide generic enclosure.....177

5 Electrical installation

Contents of this chapter.....179

Safety and liability.....179

Electrical safety precautions.....180

General notes.....181

Printed circuit boards.....181

Handling fiber-optic cables.....181

Measuring the insulation.....181

Measuring the insulation resistance of the drive.....181

Measuring the insulation resistance of the motor and motor cable.....182

Brake resistor assembly.....182



Power connections – Frames R1i...R5i.....	183
Connection procedure.....	183
Frames R1i and R2i.....	183
Frames R3i...R5i.....	184
Power connections – Frames R6i...R8i.....	185
R6i inverter module.....	185
R7i inverter module.....	186
R8i inverter module.....	187
R8i inverter module.....	187
2×R8i inverter unit.....	188
Connection procedure.....	189
Grounding the motor cable shield at the motor end.....	190
Installing the BLHF filter.....	190
Replacing ACS800 R8i modules with ACS880 R8i modules.....	192
Connecting the control cables.....	195
Installing option modules.....	196
Installing an I/O extension, fieldbus adapter or pulse encoder option module... 196	
Installing an FSO safety functions module onto UCU-22, UCU-23 or UCU-24 or BCU control unit.....	196
Installing an FSO safety functions module onto ZCU control unit.....	197
Mounting kit for FSO safety functions module.....	198
Installing the FSPS-21 PROFIsafe safety functions module.....	199
Installing the FSCS-21 CIP Safety™ functions module.....	199
Connecting a PC.....	199
Panel bus (control of several units from one control panel).....	200
Twin panel connection.....	201
Connection with FDPI-02 modules.....	201
6 UCU-22, UCU-23 and UCU-24 control units	
Contents of this chapter.....	203
General.....	203
Layout.....	204
Default control connection diagram of the inverter control unit.....	207
Additional information on the connections.....	210
Connecting motor temperature sensors to the drive.....	210
Power supply for the control unit (XPOW).....	210
Digital interlock (DIIL).....	210
Control panel connection (XPAN).....	210
The XD2D connector.....	210
Safe torque off (XSTO, XSTO OUT).....	211
Safety functions module connection (XFSO).....	211
MicroSDHC memory card slot.....	211
Connector data.....	212
Ground isolation diagram.....	214
Ground isolation diagram.....	216
Other information.....	217
7 BCU and ZCU control units	
Contents of this chapter.....	219
General.....	219
ZCU-12 layout.....	220



ZCU-14 layout.....	221
Default control connection diagram of the inverter control unit (ZCU).....	222
Layout (BCU).....	225
Default control connection diagram of the inverter control unit (BCU).....	227
Additional information on the connections.....	230
Connecting motor temperature sensors to the drive.....	230
Power supply for the control unit (XPOW).....	230
Digital interlock (DIIL).....	230
The XD2D connector.....	230
Safe torque off (XSTO, XSTO OUT).....	231
Safety functions module connection (X12).....	231
SDHC memory card slot.....	232
Connector data.....	233
BCU ground isolation diagram.....	235
ZCU ground isolation diagram.....	236
Other information.....	237



8 Installation checklist

Contents of this chapter.....	239
Checklist.....	239

9 Start-up

Contents of this chapter.....	243
Start-up procedure.....	244
Charging sequence.....	246

10 Maintenance

Contents of this chapter.....	247
Maintenance intervals.....	247
Description of symbols.....	247
Recommended maintenance intervals after start-up.....	248
Maintenance timers and counters.....	249
Cleaning.....	249
Cleaning the interior of the cabinet.....	249
Cleaning the heatsink.....	249
Cleaning the door air inlets.....	250
Cleaning the door air inlets (IP20).....	250
Cleaning the door air inlets (IP22 and IP42).....	250
Replacing the inlet door filters (IP54).....	251
Cooling fans.....	252
Replacing the module cooling fans.....	252
Replacing the R1i and R2i module cooling fan.....	252
Replacing the R3i and R4i module cooling fan.....	253
Replacing the R5i module main cooling fan.....	254
Replacing the R5i module auxiliary cooling fan.....	255
Replacing the R6i and R7i module cooling fan.....	255
Replacing R8i module cooling fan (speed-controlled version).....	256
Replacing R8i module cooling fan (direct-on-line version,option +C188).....	257
Replacing the circuit board compartment fan.....	259
Replacing the cabinet cooling fans.....	261
Cabinets with ABB air outlet kits.....	261

Cabinets with other fan types.....	261
Replacing R6i/R7i module.....	262
Replacing R8i module.....	265
BLHF filters.....	269
Capacitors.....	269
Reforming the capacitors.....	269
Control units.....	270
UCU and BCU control units.....	270
ZCU control units.....	270
Replacing the memory unit (ZCU-14).....	270
Replacing the control unit battery (ZCU-14).....	270
Control panel.....	271
LEDs and other status indicators.....	271
Control panel and panel platform/holder LEDs.....	271
LEDs of the BPA-01 board.....	272
R8i power module LEDs.....	272
Activating the reduced run function of the inverter unit.....	273
Starting reduced run operation.....	273
Resuming normal operation.....	273
Functional safety components.....	274

11 Ordering information

Contents of this chapter.....	275
Kit code key.....	276
Frames R1i...R4i.....	278
Inverter modules.....	278
Control panel.....	280
DC-side components.....	281
DC bus installation parts (for Rittal VX25 enclosures).....	281
Module-specific DC fuses (IEC, UL).....	282
Module-specific DC fuse bases (IEC, UL).....	282
Main DC switch/disconnector kits.....	283
Main DC fuses (IEC, UL).....	283
Busbars between main DC switch/disconnector and fuses.....	284
AC-side components.....	286
Output (du/dt) filters.....	286
Mechanical installation accessories.....	287
Mounting plate shroud kits.....	287
Air guide kits.....	288
Frame R5i.....	289
Inverter module.....	289
Control panel.....	291
DC-side components.....	292
DC bus installation parts (for Rittal VX25 enclosures).....	292
Module-specific DC fuses (IEC, UL).....	293
Module-specific DC fuse bases (IEC, UL).....	293
Main DC switch/disconnector kits.....	293
Main DC fuses (IEC, UL).....	294
DC busbars (IEC, UL).....	294
AC-side components.....	295
Output (du/dt) filters.....	295

Mechanical installation accessories.....	295
Mounting plate shroud kits.....	296
Fuse base shroud kit.....	296
Frames R6i and R7i.....	298
Inverter modules.....	298
Control panel.....	299
Control electronics.....	300
Control unit (UCU).....	300
Control unit (BCU).....	300
Fiber-optic cables.....	300
DC-side components.....	301
DC bus installation parts (for Rittal VX25 enclosures).....	301
DC fuses.....	302
DC switch/disconnector kits.....	304
Charging kit (R7i only).....	305
DC connection kit for Rittal VX25 enclosures.....	306
DC busbars with common mode filter holder for Rittal VX25 enclosures.....	308
DC busbars with fuse and common mode filter holders for generic enclosures.....	309
Common mode filters.....	309
AC-side components.....	310
AC busbar kit.....	310
Output (du/dt) filters.....	310
Mechanical installation accessories and tools.....	311
Inverter module mounting parts.....	311
Shrouding.....	311
Lifting device.....	311
Frame R8i and multiples.....	313
Inverter modules.....	313
Control panel.....	316
Control electronics.....	317
Control unit (UCU-22...24).....	317
Control unit (BCU).....	317
Fiber-optic cables.....	318
Control circuit plug connectors.....	318
Wire sets for use with the reduced run function.....	318
DC-side components.....	319
DC bus installation parts (for Rittal VX25 enclosures).....	319
DC connection parts 1 of 2 (for Rittal VX25 enclosures).....	319
DC connection parts 1 of 2 (for generic enclosures).....	322
DC connection parts 2 of 2 (for Rittal VX25 or generic enclosures).....	324
Common mode filters.....	325
DC fuses (IEC, UL).....	325
DC switch/disconnector kits.....	327
Charging kits.....	329
Charging resistors.....	332
AC-side components.....	334
Quick connector.....	334
Output busbars/shrouds kit.....	334
Cable entry kit.....	339
Mechanical installation accessories.....	339
Inverter module top/bottom guides.....	339



Insertion/Extraction ramp.....	341
Shrouding.....	341
BLHF filters.....	342
Filter modules.....	342
Control circuit plug connectors.....	342
Filter module top/bottom guides.....	343
AC connection parts.....	344
Shrouding.....	348
Cabinet ventilation.....	349
Air inlet kits.....	349
Air inlet kits 400 mm cabinet.....	349
Air inlet kits 600 mm cabinet.....	350
Air inlet kits 800 mm cabinet.....	351
Air outlet kits.....	351
Air outlet kits 400 mm cabinet.....	351
Air outlet kits 600 mm cabinet.....	353
Air outlet kits 800 mm cabinet.....	354
Cooling fans (frames R1i...R4i).....	357
Fan wire sets for cooling fans.....	358
Cooling fans (frames R5i).....	359
Fan wire sets for cooling fans.....	359
Cooling fans (frames R6i...R7i).....	360
Cooling fans (frames R8i).....	361
Cooling fans.....	361

12 Technical data

Contents of this chapter.....	363
Ratings.....	363
Definitions.....	366
Derating.....	368
Surrounding air temperature derating.....	368
Altitude derating.....	368
Switching frequency derating.....	369
Output frequency derating.....	369
Cooling characteristics, noise, DC capacitance.....	369
Permitted mounting orientations.....	372
Dimensions and weights.....	372
Free space requirements.....	373
Input power (DC) connection.....	374
Motor connection data.....	374
Typical power cable sizes.....	376
Terminal data for the power cables.....	377
Input terminals.....	377
Output terminals (frames R1i...R5i).....	377
Output terminals (frames R6i...R7i).....	378
Output terminals (frame R8i).....	379
Control connections.....	379
Protection classes for modules.....	380
Ambient conditions.....	380
Colors.....	381
Materials.....	381
Module.....	381

Packaging of module.....	381
Packaging of options.....	381
Manuals.....	382
Disposal.....	382
Standards.....	382
Markings.....	382
Efficiency.....	382
Energy efficiency data (ecodesign).....	382
Auxiliary power consumptions.....	383
Control equipment.....	383
Cabinet cooling fans.....	383
Definitions.....	383
Fuse data.....	384
Ferrules used with 400 V and 500 V units.....	384
Ferrules used with 690 V units.....	384
Flush-end fuse blocks used with 400 V and 500 V units.....	385
Flush-end fuse blocks used with 690 V units.....	385
Tightening torques.....	386
Electrical connections.....	386
Mechanical connections.....	386
Insulation supports.....	386
Cable lugs.....	386
Disclaimers.....	387
Generic disclaimer.....	387
Cyber security disclaimer.....	387
Declarations of conformity.....	387

13 The Safe torque off function

Contents of this chapter.....	389
Description.....	389
Compliance with the European Machinery Directive and the UK Supply of Machinery (Safety) Regulations.....	390
Wiring.....	391
Activation switch.....	391
Cable types and lengths.....	391
Grounding of protective shields.....	391
Dual-channel connection with internal power supply.....	392
Frames R1i...R7i (R6i/R7i without option +C249), with ZCU control unit.....	392
Frame R6i/R7i with option +C249, with BCU control unit.....	392
Frame R6i/R7i with option +C249, with UCU-22...24 control unit.....	393
Frame R8i and multiples with BCU control unit.....	394
Frame R8i and multiples with UCU-22...24 control unit.....	395
Single-channel connection of activation switch, with ZCU-12 control unit.....	396
Single-channel connection of activation switch, with ZCU-14 or BCU control unit.....	397
Single-channel connection of activation switch, with UCU-22...24 control unit...	398
Multiple inverter units.....	399
Internal power supply (example, inverter unit with ZCU or BCU control unit).	399
Internal power supply (example, inverter unit with UCU-22...24 control unit)..	400
External power supply (example, inverter unit with ZCU or BCU control unit).	401
External power supply (example, inverter unit with UCU-22...24 control unit).	402
Operation principle.....	403

Start-up including validation test.....	404
Competence.....	404
Validation test reports.....	404
Validation test procedure.....	404
Use.....	406
Maintenance.....	408
Competence.....	408
Perfect proof test procedure.....	409
Simplified proof test procedure.....	409
Fault tracing.....	410
Safety data.....	411
Terms and abbreviations.....	413
TÜV certificate.....	414

14 Resistor braking using frames R1i...R4i inverter modules

Contents of this chapter.....	415
Using R1i...R4i modules for resistor braking.....	415
Planning the braking system.....	415
Restrictions.....	416
Selecting the brake resistor.....	416
Selecting and routing the brake resistor cables.....	417
Minimizing electromagnetic interference.....	417
Maximum cable length.....	417
Selecting the installation location for the brake resistors.....	417
Protecting the system against thermal overload.....	417
Protecting the resistor cable against short circuit.....	418
Mechanical installation.....	418
Electrical installation.....	419
Checking the insulation of the brake resistor assembly.....	419
Connection procedure.....	419
Start-up.....	420
Technical data.....	421
Ratings.....	421
Definitions.....	422
Resistor dimensions.....	423
Resistor connectors on inverter modules.....	424

15 Dimension drawings

Contents of this chapter.....	425
Frame R1i.....	426
Frame R2i.....	427
Frame R3i.....	428
Frame R4i.....	429
Frame R5i.....	430
Frame R6i.....	431
Frame R6i with options +V992 and +C249.....	432
Frame R7i.....	433
Frame R7i with options +V992 and +C249.....	434
Frame R8i.....	435
Frame R8i with option +P942.....	437



Control electronics.....	440
ZCU control unit.....	440
UCU-22 control unit.....	441
BCU control unit.....	442
DPMP-01 door mounting kit.....	443
DC fuses and fuse bases.....	444
Fuse, 14 × 51 mm.....	444
Mersen US141 (Z331153F) fuse disconnecter (for 14 × 51 mm fuses).....	444
Fuse, 27 × 60 mm.....	445
Mersen US271MI (R227600C) fuse disconnecter (for 27 × 60 mm fuses).....	445
Mersen PS272PREMCPS (N220076) fuse disconnecter (for R5i, 27 × 60 mm fuses).....	446
DC fuse blocks (Bussmann).....	447
Switchgear and charging components.....	448
OS_ switch fuses.....	448
OS100GJ04FP.....	448
OS160GD04F.....	449
OS200DZ22F.....	450
OT_ switch/disconnectors.....	451
OT200E11.....	451
OT200U11.....	452
OT400E11.....	453
OT400E22.....	454
OT400U11.....	455
OT400U22.....	456
OT600U11, OT630E11.....	457
OT1200U_, OT1600E_.....	458
OT2500E22.....	459
OHB_ switch handles.....	460
OHB65J6, OHB125J12, OHB145J12.....	460
OHB150J12P.....	460
OHB274J12.....	461
OA1G10/OA3G01 auxiliary contact blocks.....	461
AF190-30-00-13 contactor.....	462
Charging controller.....	463
Charging resistor (frame R7i).....	464
Charging resistor (frame R8i).....	464
Miscellaneous components.....	465
Cooling fan 3AXD5000000592.....	465
Cooling fan 3AXD50000006111.....	465
Output (du/dt) filters for frames R1i...R5i.....	466
Common mode filters.....	467
Quick connector for frame R8i.....	467
Insertion/extraction ramp for frame R8i modules.....	469

16 Circuit diagrams

Contents of this chapter.....	471
Component designations used in the diagrams.....	471
Frames R1i...R5i.....	471
Frame R6i.....	472
Frame R7i.....	472
Frame R8i and multiples.....	473

Frames R1i...R4i.....	474
Frames R1i...R4i – Sheet 000A.....	474
Frames R1i...R4i – Sheet 000B.....	475
Frames R1i...R4i – Sheet 000C.....	476
Frames R1i...R4i – Sheet 300A.....	477
Frames R1i...R4i – Sheet 001a.....	478
Frames R1i...R4i – Sheet 003a.....	479
Frames R1i...R4i – Sheet 020a.....	480
Frames R1i...R4i – Sheet 021a.....	481
Frames R1i...R4i – Sheet 026a.....	482
Frames R1i...R4i – Sheet 040a.....	483
Frames R1i...R4i – Sheet 040b.....	484
Frames R1i...R4i – Sheet 040c.....	485
Frames R1i...R4i – Sheet 040d.....	486
Frames R1i...R4i – Sheet 041a.....	487
Frames R1i...R4i – Sheet 061a.....	488
Frame R5i.....	489
Frame R5i – Sheet 000A.....	489
Frame R5i – Sheet 000B.....	490
Frame R5i – Sheet 000C.....	491
Frame R5i – Sheet 300A.....	492
Frame R5i – Sheet 001a.....	493
Frame R5i – Sheet 003a.....	494
Frame R5i – Sheet 020a.....	495
Frame R5i – Sheet 021a.....	496
Frame R5i – Sheet 026a.....	497
Frame R5i – Sheet 040a.....	498
Frame R5i – Sheet 040b.....	499
Frame R5i – Sheet 040c.....	500
Frame R5i – Sheet 040d.....	501
Frame R5i – Sheet 041a.....	502
Frame R5i – Sheet 061a.....	503
Frame R6i.....	504
Frame R6i – Sheet 000A.....	504
Frame R6i – Sheet 000B.....	505
Frame R6i – Sheet 000C.....	506
Frame R6i – Sheet 300A.....	507
Frame R6i – Sheet 001a.....	508
Frame R6i – Sheet 020a.....	509
Frame R6i – Sheet 040a.....	510
Frame R6i – Sheet 040b.....	511
Frame R6i – Sheet 040c.....	512
Frame R6i – Sheet 041a.....	513
Frame R7i.....	514
Frame R7i – Sheet 000A.....	514
Frame R7i – Sheet 000B.....	515
Frame R7i – Sheet 000C.....	516
Frame R7i – Sheet 300A.....	517
Frame R7i – Sheet 020a.....	518
Frame R7i – Sheet 040a.....	519
Frame R7i – Sheet 040b.....	520
Frame R7i – Sheet 040c.....	521



Frame R7i – Sheet 041a.....	522
Frame R7i – Sheet 001a.....	523
Frame R7i – Sheet 005a.....	524
Frame 1×R8i.....	525
Frame 1×R8i (with DC switch/disconnector) – Sheet 000A.....	525
Frame 1×R8i – Sheet 000B.....	526
Frame 1×R8i – Sheet 000C.....	527
Frames 1×R8i and 2×R8i – Sheet 300A.....	528
Frame 1×R8i – Sheet 001a.....	529
Frame 1×R8i – Sheet 002a.....	530
Frame 1×R8i – Sheet 005a.....	531
Frame 1×R8i – Sheet 020a.....	532
Frames 1×R8i and 2×R8i – Sheet 021a.....	533
Frames 1×R8i and 2×R8i – Sheet 040a.....	534
Frames 1×R8i and 2×R8i – Sheet 040b.....	535
Frame 1×R8i – Sheet 040c.....	536
Frames 1×R8i and 2×R8i – Sheet 040d.....	537
Frames 1×R8i and 2×R8i – Sheet 041a.....	538
Frames 1×R8i and 2×R8i – Sheet 061a.....	539
Frames 1×R8i and 2×R8i – Sheet 095a.....	540
Frame R8i multiples.....	541
Frame 2×R8i – Sheet 000A.....	541
Frame 2×R8i – Sheet 000B.....	542
Frame 2×R8i – Sheet 000C.....	543
Frame 2×R8i – Sheet 001a.....	544
Frame 2×R8i – Sheet 005a.....	545
Frame 2×R8i – Sheet 020a.....	546
Frame 2×R8i – Sheet 040c.....	547

Further information



1

Introduction to the manual

Contents of this chapter

This chapter gives the basic information on the manual.

Applicability

The manual applies to ACS880-104 inverter modules (frame sizes R1i...R8i) and inverter units (frame sizes 2×R8i...10×R8i) intended for user-defined cabinet installations.

Safety instructions

Obey all safety instructions of the drive.

- Read the **complete safety instructions** before you install, commission, use or service the drive. The complete safety instructions are given in [ACS880 multidrives cabinets and modules safety instructions \(3AUA0000102301 \[English\]\)](#).
- Read the warnings of the software function before you take the function in use or change its default parameter settings. Read the warnings of the parameter before you change its default setting. Refer to the firmware manual.

Target audience

This manual is intended for people who plan the installation, install, commission, and do maintenance work on the drive, or create instructions for the end user of the drive concerning the installation and maintenance of the drive.

Read the manual before you do work on the drive. You are expected to know the fundamentals of electricity, wiring, electrical components, and electrical schematic symbols.

Categorization by frame size and option code

The instructions and technical data which concern only certain module or frame sizes are marked with the size identifier.

The module size can be identified from the basic code visible on the type designation label, for example, ACS880-104-0100A-3 where 0100A is the module size. The option codes of the module are listed after the plus sign.

The frame size of a module can be, for example, R1i, R4i, R7i, R8i or 3×R8i (the latter describing an inverter unit consisting of three parallel-connected R8i inverter modules). See the technical data for the units and frame sizes.

Use of component designations

Some device names in the manual include the component designation in brackets (for example, [Q20]). This will help you to identify the components in the circuit diagrams.

Terms and abbreviations

Term	Description
BCU	Type of control unit
Drive	Frequency converter for controlling AC motors
EMC	Electromagnetic compatibility
EMI	Electromagnetic interference
FEN-01	Optional TTL incremental encoder interface module
FEN-11	Optional absolute encoder interface module
FEN-21	Optional resolver interface module
FEN-31	Optional HTL incremental encoder interface module
FIO-11	Optional analog I/O extension module
FPTC-01	Optional thermistor protection module
FPTC-02	Optional ATEX-certified thermistor protection module for potentially explosive atmospheres
Frame, frame size	Physical size of the drive or power module
FSO-12, FSO-21	Optional functional safety modules
IGBT	Insulated gate bipolar transistor
Inverter unit	Inverter module(s) under control of one control unit, and related components. One inverter unit typically controls one motor.
Module charging circuit	A charging circuit inside the module
Power module	Common term for drive module, inverter module, supply module, brake chopper module etc.
RFI	Radio-frequency interference
STO	Safe torque off (IEC/EN 61800-5-2)
Supply unit	Supply module(s) under control of one control unit, and related components.
UCU	Type of control unit
Unit charging circuit	DC-DC charging circuit for a cubicle

Related documents

For more documentation, go to www.abb.com/drives/documents.

You can find more documentation related to the multidrive modules on the Internet at <https://sites-apps.abb.com/sites/lvacdrivesengineeringssupport/content>.



[Manuals for ACS880 multidrive modules](#)

A large, light gray square with rounded corners, centered on the page. Inside the square is a large, bold, black number '2'.

Hardware description

Contents of this chapter

This chapter describes a typical drive system and the hardware of ACS880-104 inverter modules.

Overview diagram of the drive system

The diagram that follows shows an example of a multidrive. The supply unit connects the drive to the AC supply network. It converts the AC voltage into DC. The DC voltage is distributed through the DC link to all inverter units and optional brake units. The inverter unit converts the DC back to AC that rotates the motor. The brake unit (optional) conveys energy to brake resistors whenever needed.

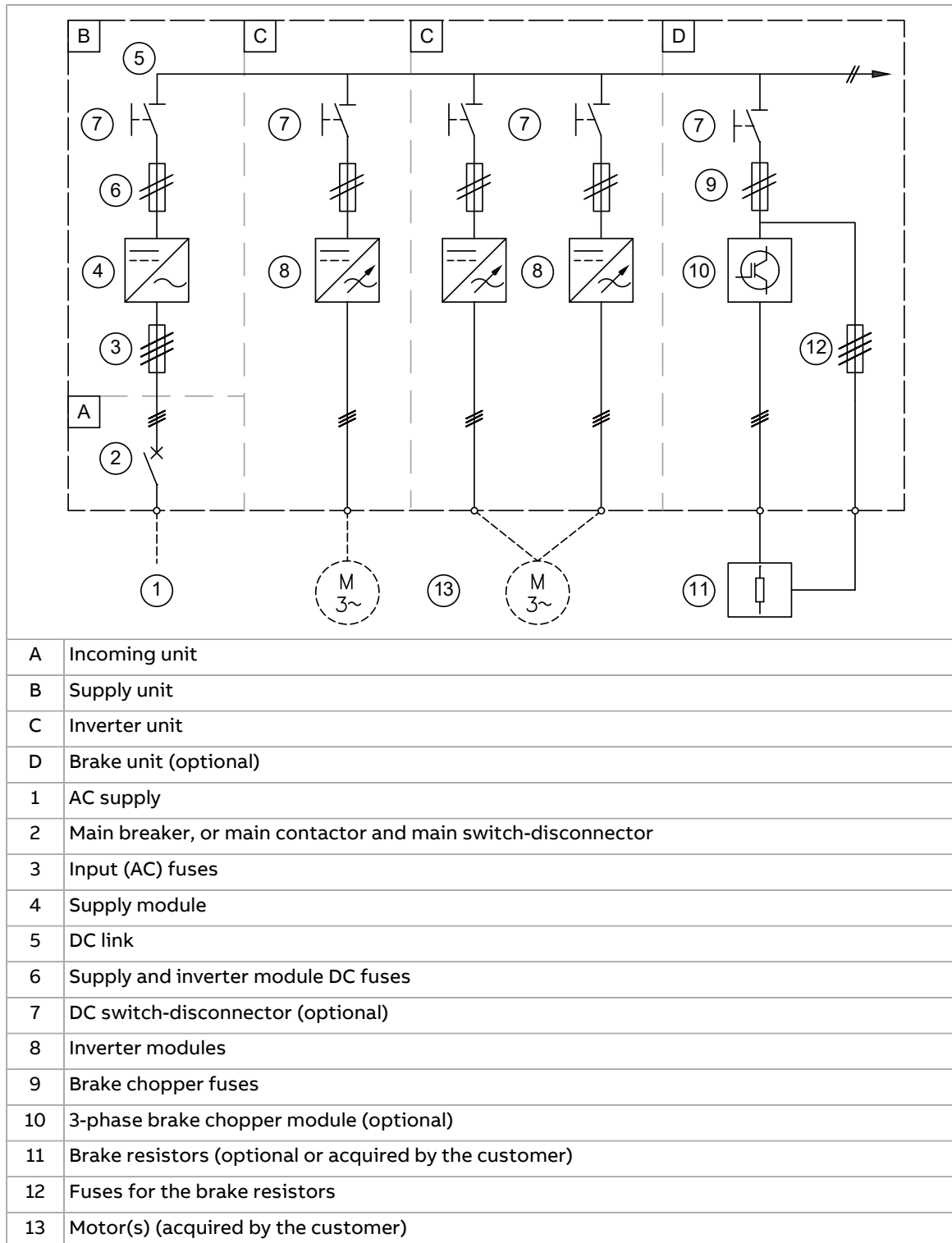

Inverter module hardware

■ General

An inverter unit contains the components required to control one motor. These include one or more inverter modules connected in parallel, together with the necessary auxiliary equipment, such as control electronics, fusing, cabling, and switchgear.

ACS880-104 inverter modules can be used to construct inverter units with a power rating from 2.5 kW up to several megawatts. Up to approximately 500 kW, inverter units consist of one module only. Higher power ratings are achieved by connecting multiple modules in parallel.

All inverter modules have coated circuit boards as standard.

■ Frames R1i...R4i

General

The DC input terminals are located at the top of the module and the AC output terminals are located at the bottom. The control unit is mounted onto the module front cover. The control unit contains the basic I/Os and slots for optional I/O modules. Other optional equipment is primarily installed on separate mounting plates.

DC connection and capacitor charging

The system integrator installs external DC fuses for the inverter module. The system integrator can also install a DC switch-disconnector if it is necessary to have a quick isolator between the inverter module(s) and the drive DC bus.

The inverter module has a module charging circuit as standard.

This figure shows the DC switch-disconnector and charging concept for frame R1i...R4i modules.

26 Hardware description

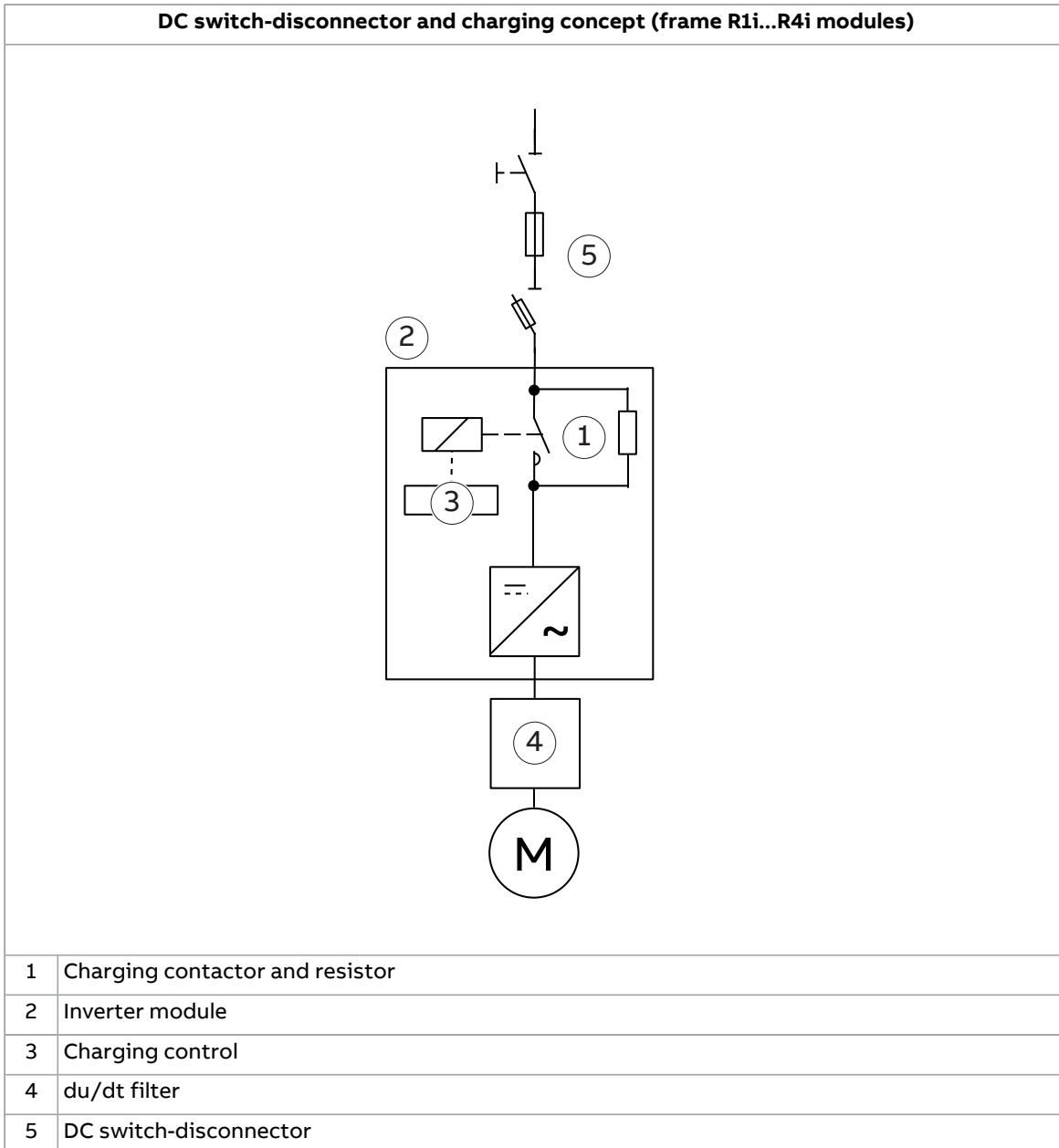

Frame R1i layout

Frame R1i is pictured (frame R2i has a similar layout).

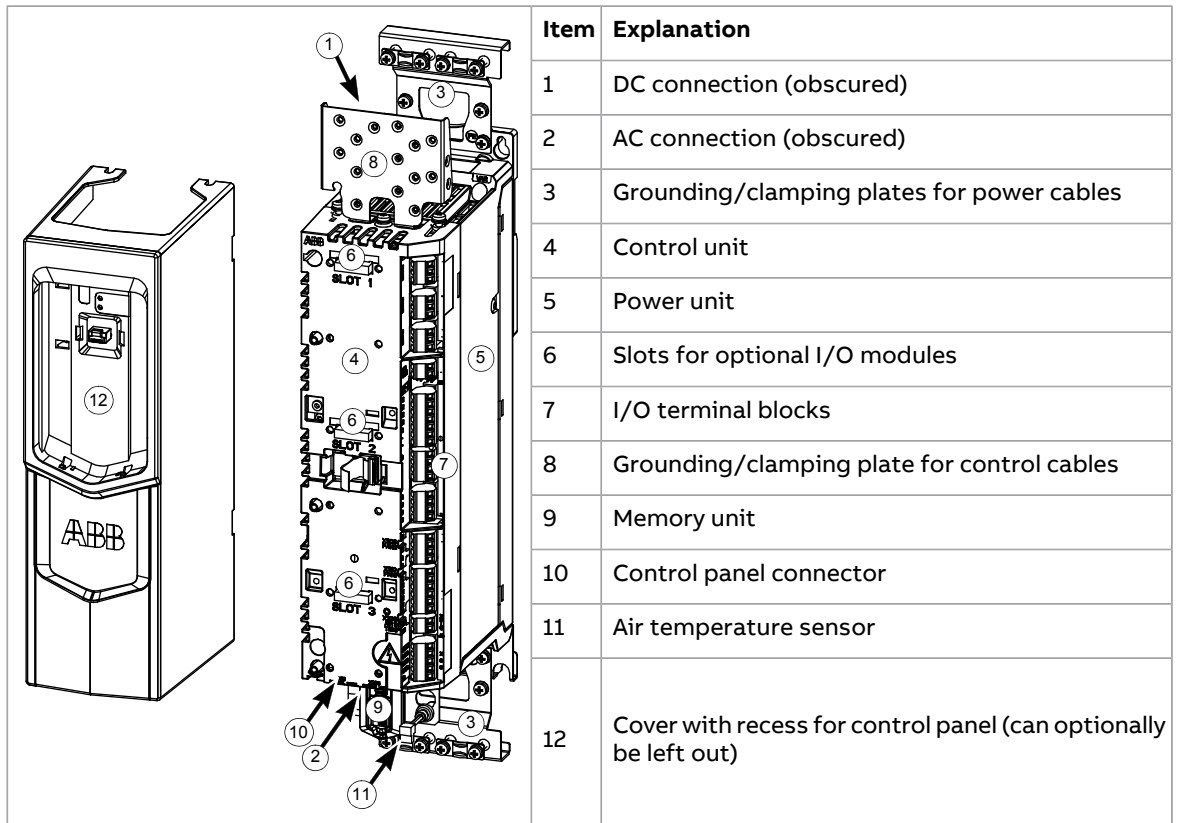

Frame R4i layout

Frame R4i is pictured (frame R3i has a similar layout).

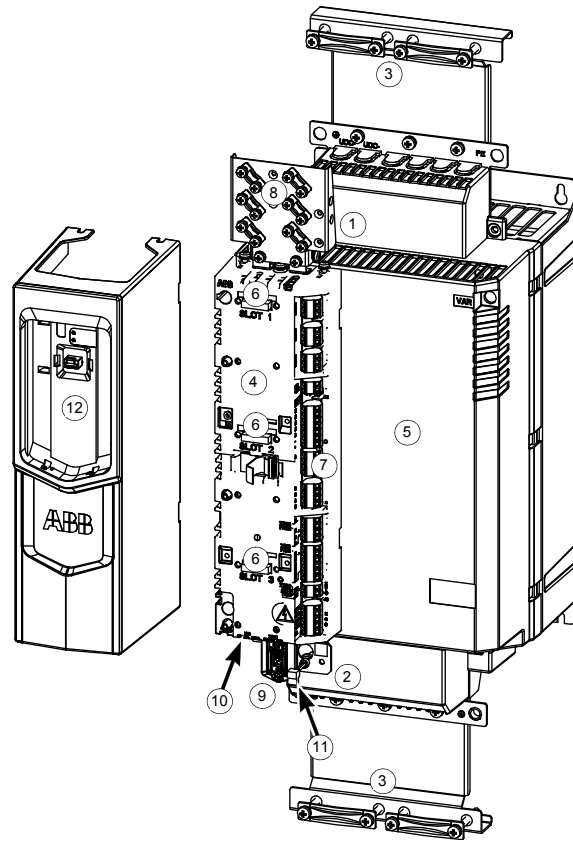

1	DC connection (under connector cover)
2	AC connection (under connector cover)
3	Grounding/clamping plates for power cables
4	Control unit
5	Power unit
6	Slots for optional I/O modules
7	I/O terminal blocks
8	Grounding/clamping plate for control cables
9	Memory unit
10	Control panel connector
11	Air temperature sensor
12	Cover with panel mounting platform (can optionally be left out)

Overview circuit diagram of an inverter cubicle (frames R1i...R4i)

The following figure shows a simplified connection example of an inverter cubicle containing several frame R1i...R4i inverter modules.

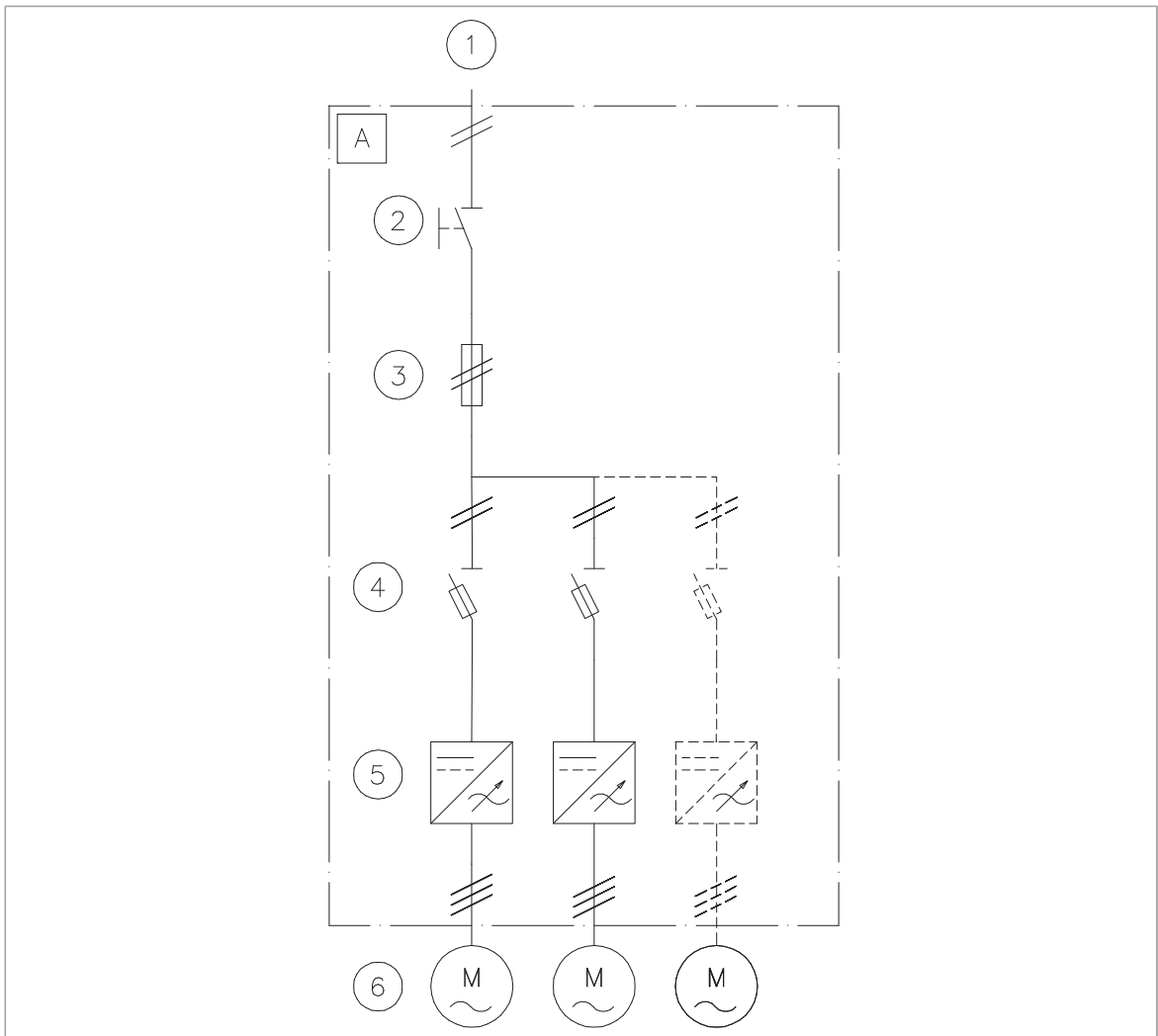

Item	Explanation	Available through
A	Inverter cubicle	-
1	DC supply	-
2	DC switch/disconnector	ABB or third party
3	Common DC fuses	ABB or third party
4	Fuse disconnecter	ABB or third party
5	Inverter modules	ABB
6	Motor	ABB (not part of ACS880-104 product offering) or third party

Cabinet layout and cooling

Refer to chapter [Cabinet construction \(page 55\)](#).

■ **Frame R5i**

General

The DC input and AC output terminals are located at the bottom of the module. The control unit is mounted underneath the front cover. The control unit contains the basic I/Os and slots for optional I/O modules. Other optional equipment is primarily installed on separate mounting plates.

DC connection and capacitor charging

The system integrator installs external DC fuses for the inverter module. The system integrator can also install a DC switch-disconnector if it is necessary to have a quick isolator between the inverter module(s) and the drive DC bus.

The inverter module has a module charging circuit as standard.

This figure shows the DC switch-disconnector and charging concept for frame R5i modules.

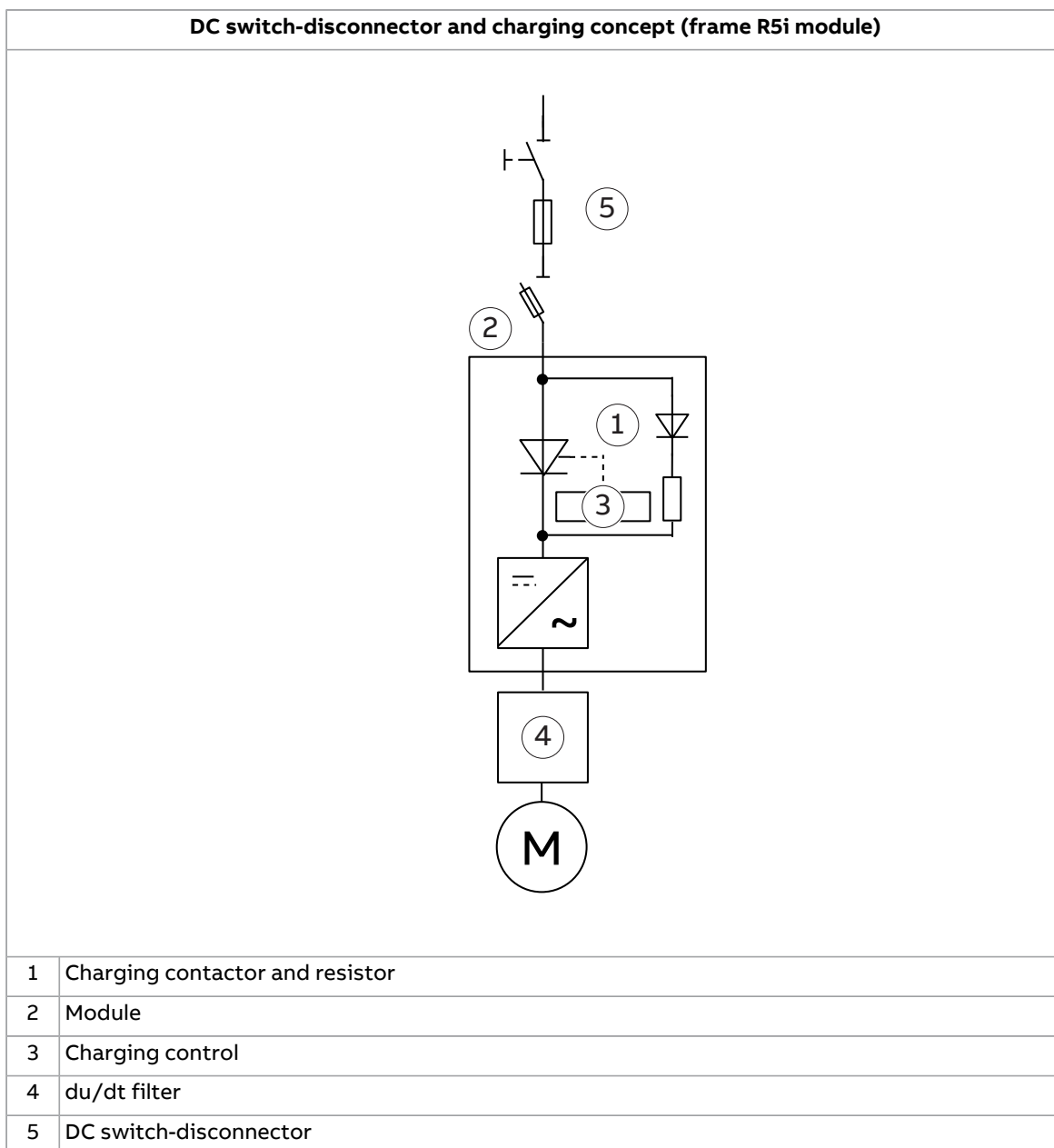

Frame R5i layout

	Item	Explanation
	1	DC connection
	2	AC connection
	3	Control unit
	4	I/O terminal blocks
	5	Slots for optional I/O modules
	6	Memory unit
	7	Control panel holder
	8	Cooling fan
	9	Front cover
	10	Front cover retaining clip To remove the front cover, use a screwdriver to push the clip down, and pull cover outwards by its bottom edge.
	11	Varistor board and EMC filter connecting screws (VAR and EMC). Not present in an ACS880-104.

Overview circuit diagram of an inverter cubicle (frame R5i)

The following figure shows a simplified connection example of an inverter cubicle containing several frame R5i inverter modules.

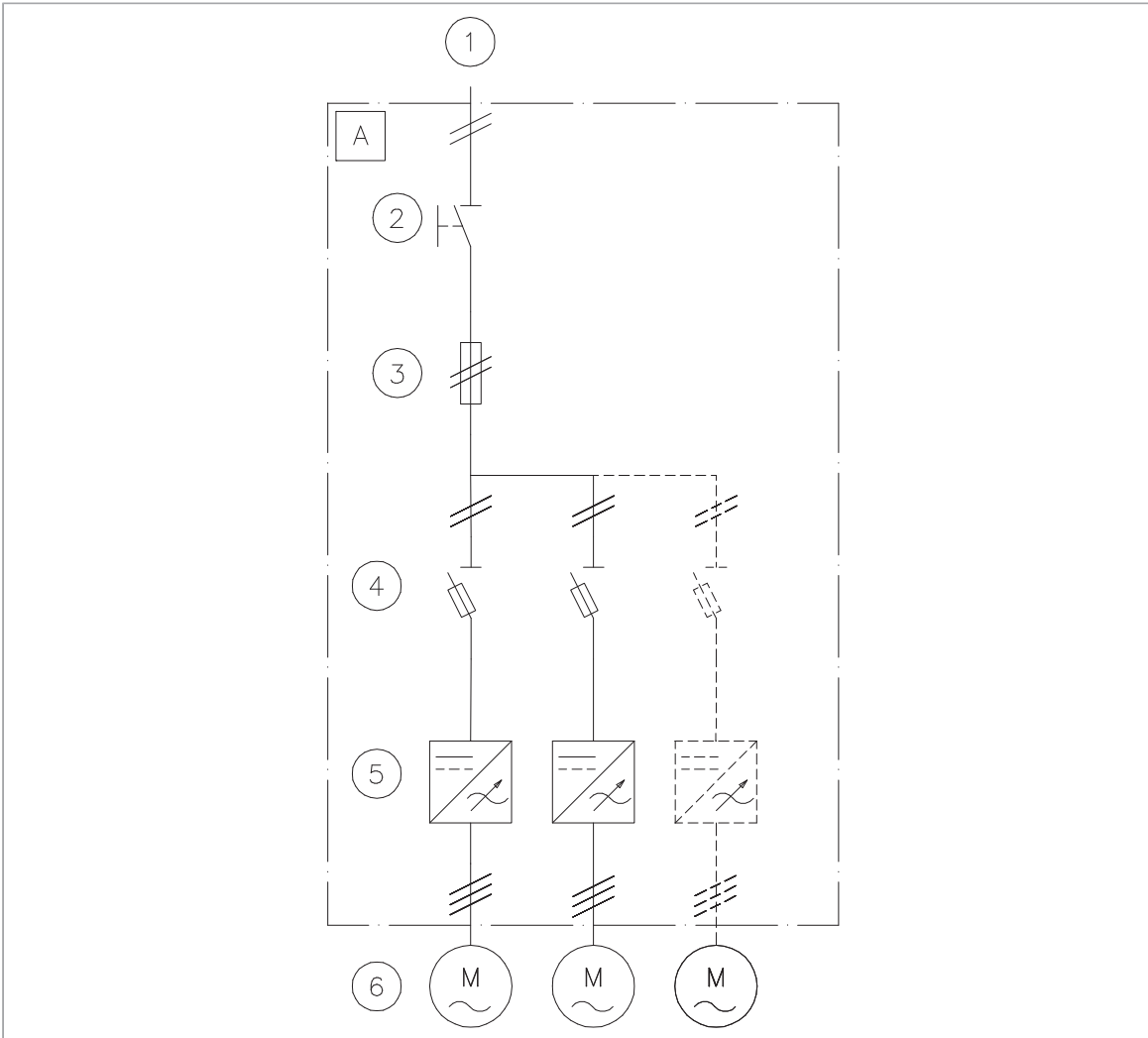

Item	Explanation	Available through
A	Inverter cubicle	-
1	DC supply	-
2	DC switch/disconnector	ABB or third party
3	Common DC fuses	ABB or third party
4	Fuse disconnecter	ABB or third party
5	Inverter modules	ABB
6	Motor	ABB (not part of ACS880-104 product offering) or third party

Cabinet layout and cooling

Refer to chapter [Cabinet construction \(page 55\)](#).

■ Frames R6i and R7i

General

The DC input terminals are located at the top of the module. The AC output terminals are located at the bottom. The control unit is mounted onto the module. The control unit contains the basic I/Os and slots for optional I/O modules. Other equipment is primarily installed on separate mounting plates.

Frame R6i or R7i module ordered with option +V992 has version 2 of the hardware. Hardware version +V992 is mechanically and electrically backward-compatible with modules without option +V992. However, ACS880 primary control program v3.40 and later versions only support option +V992.

DC connection and capacitor charging

The system integrator installs external DC fuses for the inverter module. The panel builder can also install a DC switch-disconnector if it is necessary to have a quick isolator between the inverter module(s) and the drive DC bus.

The system integrator installs a unit charging circuit if:

- the module is connected to the DC bus through a DC switch-disconnector, or
- the module is directly connected to the DC bus and the supply unit of the system does not have a charging capability.

Implementation instructions for frame R6i modules:

- Order the module with option +F272. It has a module charging circuit.

Implementation instructions for frame R7i modules:

- Order the module with option +F272. It has a module charging circuit.
- Install a charging contactor and charging resistors outside the module.

An internal monitoring board that uses a voltage of 230 V DC controls the charging contactor.

For common mode filtering, put the DC bus through the ferrite cores at the input of the module.

This figure shows the DC switch-disconnector and charging concepts for frames R6i and R7i.

DC switch-disconnector and charging concept (frame R6i module with option +F272)	DC switch-disconnector and charging concept (frame R7i module with option +F272)
1	Internal capacitor charging circuit, option +F272
2	Module
3	Charging control
4	du/dt filter
5	DC switch-disconnector
6	Charging contactor and resistors

Frame R6i and R7i layout (without option +C249)

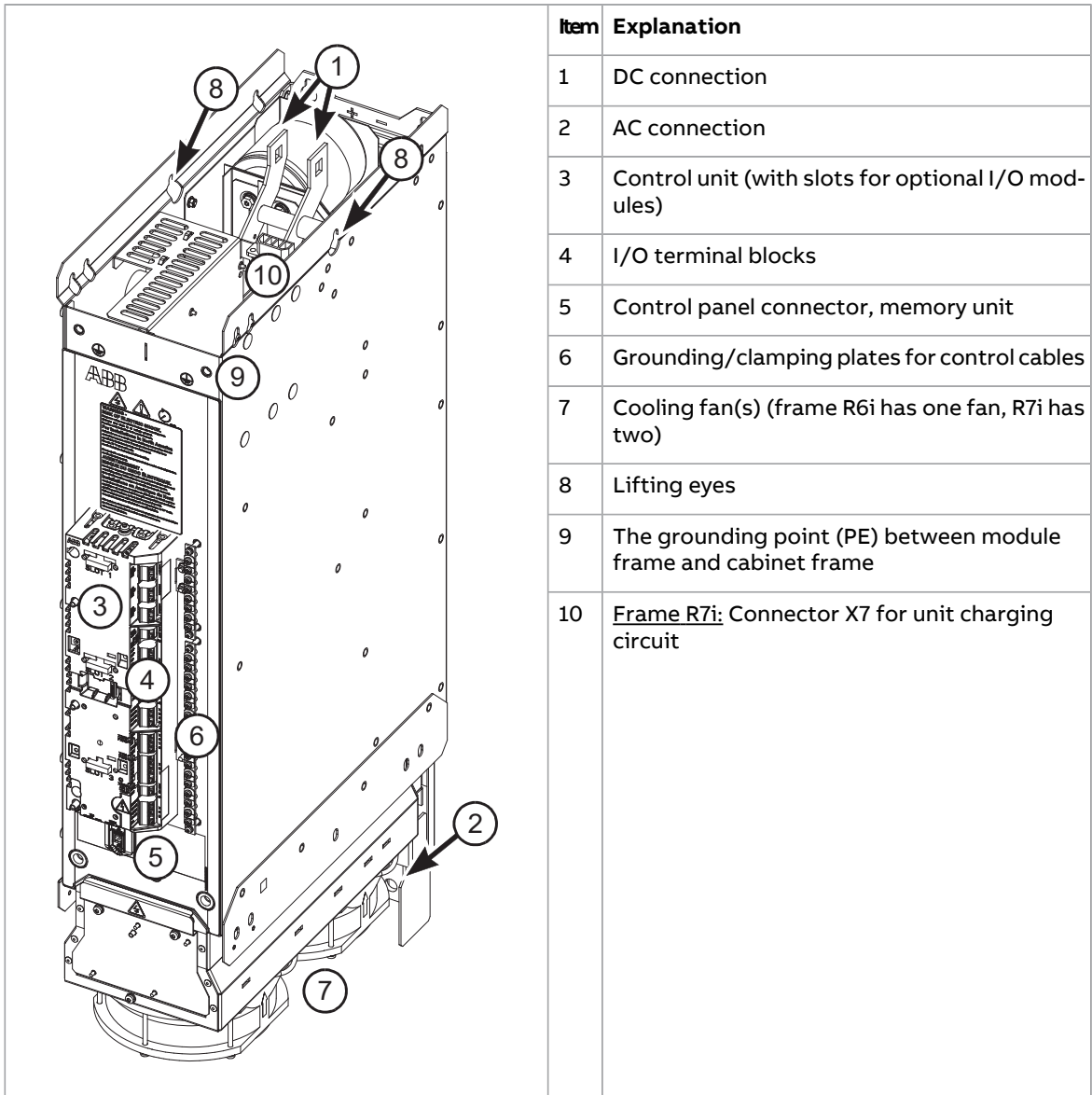

Item	Explanation
1	DC connection
2	AC connection
3	Control unit (with slots for optional I/O modules)
4	I/O terminal blocks
5	Control panel connector, memory unit
6	Grounding/clamping plates for control cables
7	Cooling fan(s) (frame R6i has one fan, R7i has two)
8	Lifting eyes
9	The grounding point (PE) between module frame and cabinet frame
10	<u>Frame R7i</u> : Connector X7 for unit charging circuit

Frame R6i and R7i layout (options +V992 and +C249)

	Item	Explanation	
	1	DC connection	
	2	AC connection	
	3	Terminal blocks:	
		X1 (STO IN)	STO input
		X2 (24V OUT)	Control unit power supply
	4	Fiber optic connections:	
		V10	Fiber-optic transmitter (signal to control unit)
		V20	Fiber-optic receiver (signal from control unit)
5	LEDs:		
	24V OUT FAULT	INTERNAL POWER OK	
6	Cooling fan(s) (frame R6i has one fan, R7i has two)		
7	Lifting eyes		
8	The grounding point (PE) between module frame and cabinet frame		
9	<u>Frame R7i:</u> Connector X7 for unit charging circuit		

Connectors X1 and X2

	<table border="1"> <tr><th colspan="4">STO IN</th></tr> <tr><th colspan="4">X1</th></tr> <tr><td>GND</td><td>+24V</td><td>GND</td><td>+24V</td></tr> </table>	STO IN				X1				GND	+24V	GND	+24V	X1	STO IN	<p>24 V Safe torque off (STO) signals from control unit</p> <p>Note: By default, the Safe torque off (STO) terminals are energized by jumpering from terminal X2. If the STO function is required, remove the jumpering and wire the signals from the control unit. Refer to chapter The Safe torque off function (page 389).</p>
STO IN																
X1																
GND	+24V	GND	+24V													
	<table border="1"> <tr><th colspan="2">24V OUT</th></tr> <tr><th colspan="2">X2</th></tr> <tr><td>GND</td><td>+24V</td></tr> </table>	24V OUT		X2		GND	+24V	X2	24V OUT	<p>Control unit power supply.</p> <p>Note: For powering the control unit (max 2 A).</p>						
24V OUT																
X2																
GND	+24V															

Connector X7

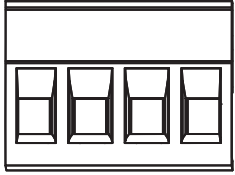
	X7				X7	<u>Frame R7i, option +F272:</u> Unit charging circuit connector. Connector counterpart is included in charging kit 3AXD50000018982.
	1	2	3	4		
	CONT+	CONT-	FB OUT	FB IN		

Fiber optic connectors V10 and V20

<table border="1" style="display: inline-table; vertical-align: middle;"> <tr><td>V10</td></tr> <tr><td>V20</td></tr> </table> 	V10	V20	Control unit connection.
V10			
V20			

Overview circuit diagram of an inverter cubicle (frame R6i)

The following figure shows a simplified connection example of an inverter unit based on a frame R6i inverter module.

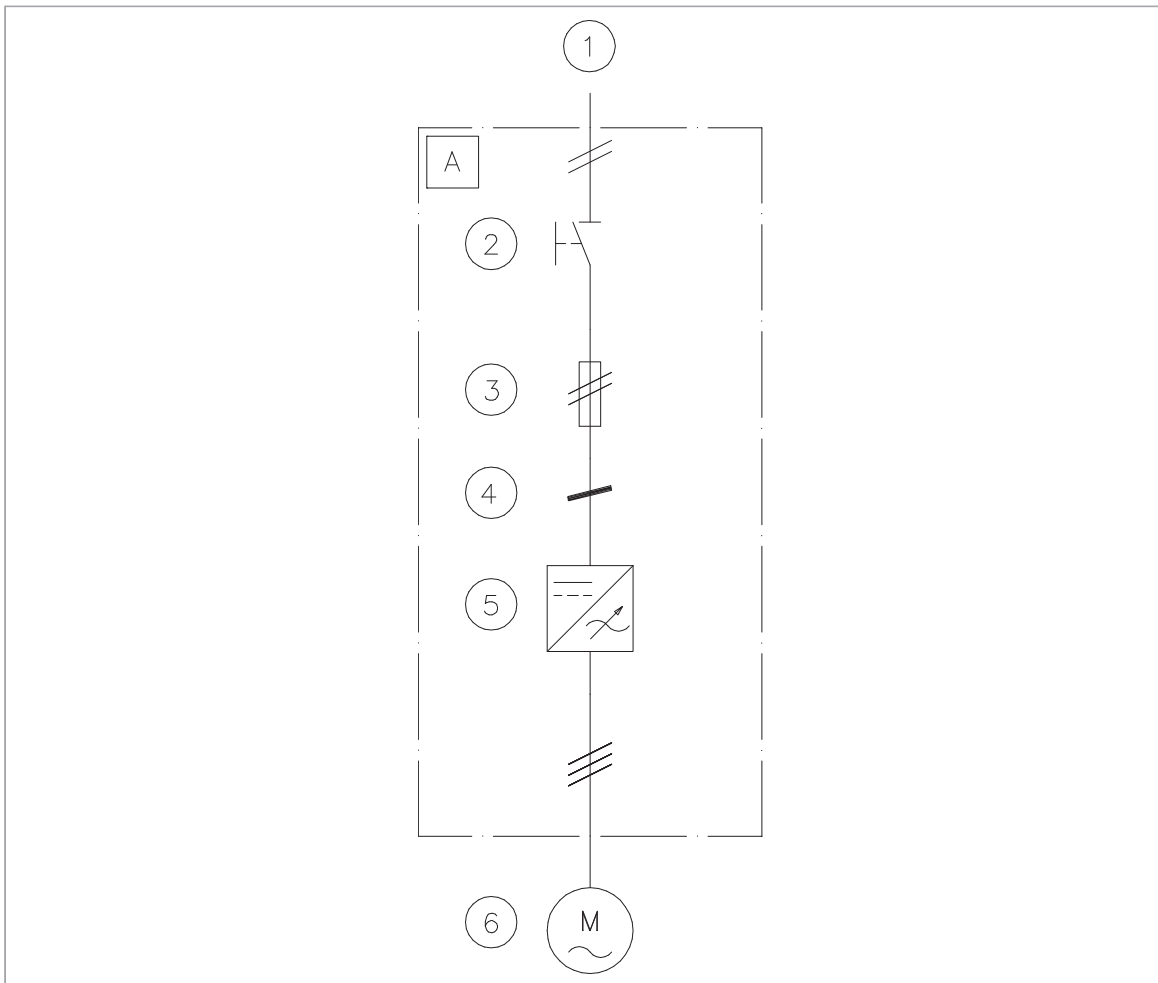

Item	Explanation	Available through
A	Inverter cubicle	-
1	DC supply	-
2	DC switch/disconnector (optional)	ABB or third party
3	DC fuses	ABB or third party
4	Common mode filters	ABB
5	Inverter module	ABB
6	Motor	ABB (not part of ACS880-104 product offering) or third party

Overview circuit diagram of an inverter cubicle (frame R7i)

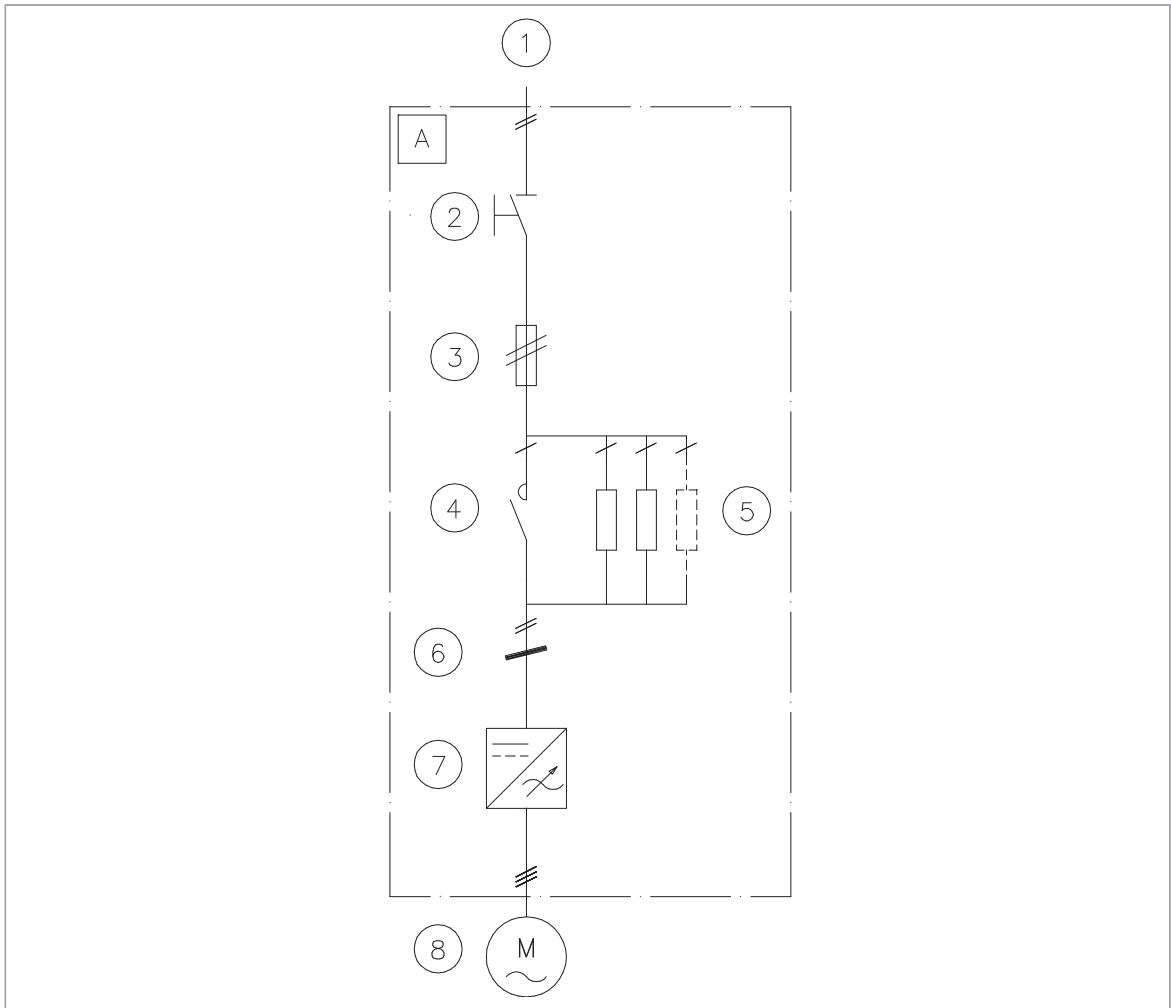

Item	Explanation	Available through
A	Inverter cubicle	-
1	DC supply	-
2	DC switch/disconnector (optional)	ABB or third party
3	DC fuses	ABB or third party
4	Charging contactor (optional)	ABB or third party
5	Charging resistor (optional)	ABB or third party
6	Common mode filters	ABB
7	Inverter module	ABB
8	Motor	ABB (not part of ACS880-104 product offering) or third party

Cabinet layout and cooling

See chapter [Cabinet construction \(page 55\)](#).

■ Frame R8i and multiples

General

Frame R8i modules are used to achieve output powers from approximately 250 kW up.

Frame R8i modules are used in single or parallel configurations. R8i modules have wheels, and can easily be removed from the cubicle for cable installation or service.

The motor connection is via a quick connector at the back of the module that couples when the module is inserted into the cubicle. Each parallel-connected module is cabled separately to the motor, or connected by busbars to adjacent modules to reduce the number of cables. It is also possible to build an AC bus from each module to a separate output cubicle.

As standard, the cooling fan is automatically speed-controlled according to the loading of the inverter module. The fan is supplied internally.

If a direct-on-line fan (option +C188) is used, the installer must connect the fan supply (400 V AC / 50/60 Hz or 320 V AC / 60 Hz) to the terminal block [X50].

Internal du/dt filtering is optional for single-module 400/500 V inverter units, but mandatory with all 690 V units and all parallel-connected modules.

Frame R8i (and multiples, if any) modules are controlled by a single control unit installed separately from the module(s). The control unit is connected to each module by a fiber-optic link. The control unit can be powered from the module (terminal block X53), from an external 24 V DC supply, or both for redundancy. The control unit contains the basic I/Os and slots for optional I/O modules. Other equipment is primarily installed on separate mounting plates.

DC connection and capacitor charging

The system integrator installs external DC fuses to the inverter module. The panel builder can also install a DC switch-disconnector if it is necessary to have a quick isolator between the inverter module(s) and the drive DC bus.

The system integrator can install a unit charging circuit if:

- the module is connected to the DC bus through a DC switch-disconnector, or
- the module is directly connected to the DC bus and the supply unit of the system does not have charging capability.

The charging circuit that is shown in this manual consists of a charging switch, resistors and charging controller. When the module is connected to an energized DC bus, the charging switch closes first. After charging, you can close the main DC switch-disconnector and open the charging switch. The module will not operate if the charging switch is closed. Stop the drive before you open the DC switches.

For common mode filtering, put the DC bus through the ferrite cores at the input of the module.

This figure shows the DC switch and charging concept for frame R8i modules.

DC switch-disconnector and charging concept (frame R8i module)

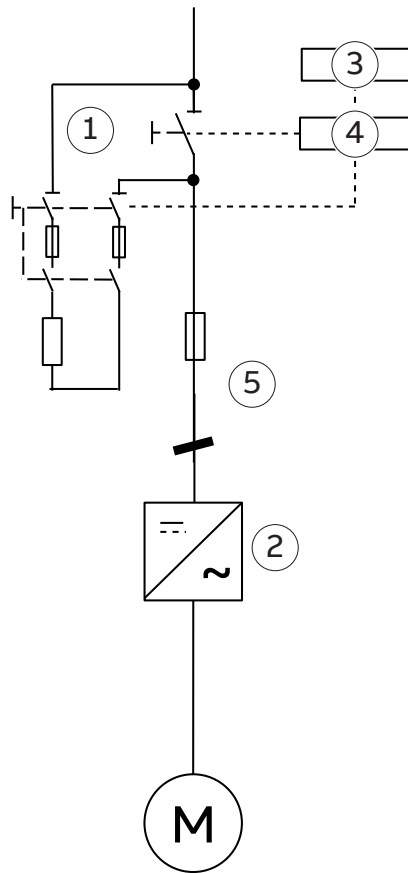

1	DC switch-disconnector and charging circuit
2	Module
3	Charging control, such as software and parameters
4	BSFC-12C board to control the DC switch-disconnector and charging circuit
5	DC switch-disconnector

Frame R8i layout

This figure shows the layout of the R8i module.

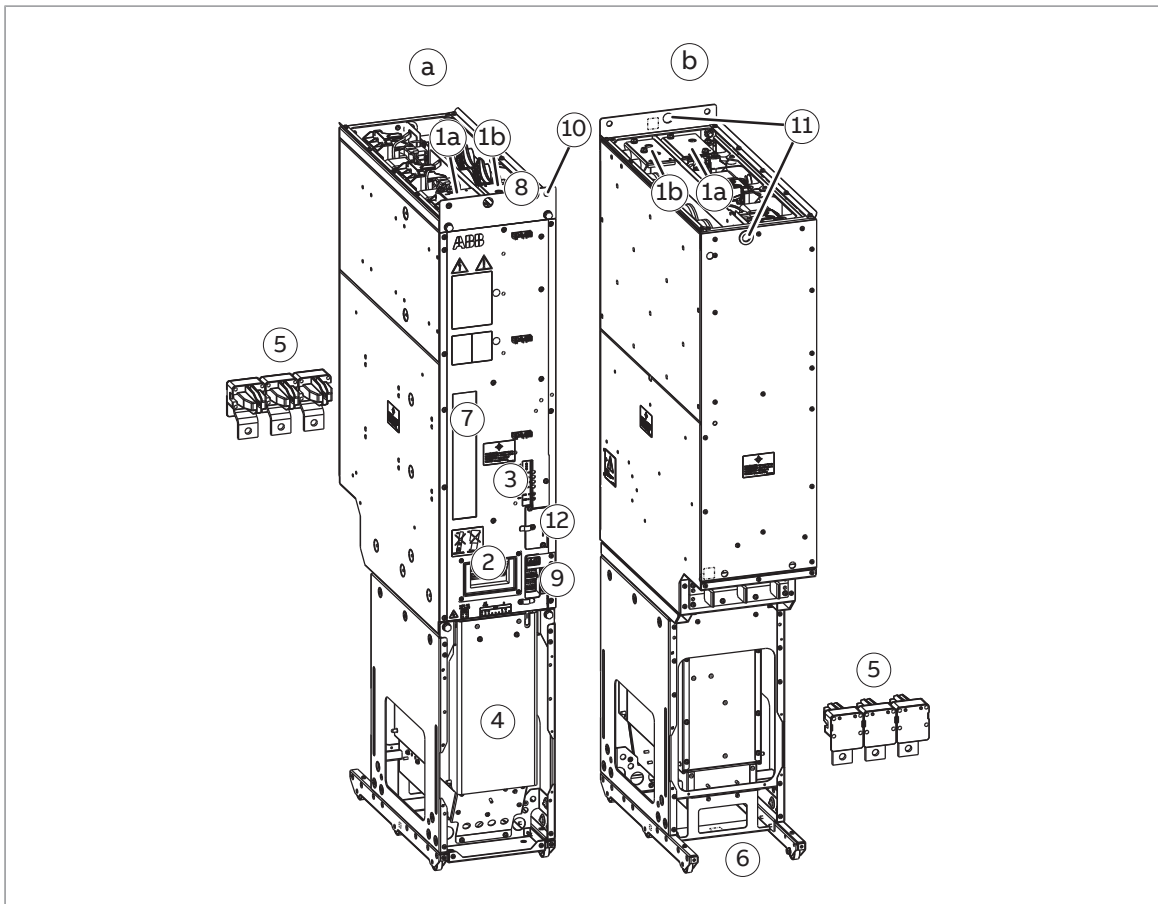

A	R8i module, front
B	R8i module, back
1	DC- busbar (a), DC+ busbar (b)
2	Handle
3	LEDs and fiber optic connectors
4	Fan (standard speed-controlled fan shown; a direct-on-line fan is available as option +C188)
5	Quick connector (three phases). The counterpart is fastened to the cabinet behind the module.
6	Wheels
7	Type designation label
8	Terminal block [X50] (power supply for internal boards and module heating element, option +C183; DOL fan supply, option +C188)
9	Connectors [X51], [X52], [X53]
10	The unpainted grounding point (PE) between module frame and cabinet frame.
11	Lifting eyes
12	Circuit board compartment fan

Connectors X50...X53

R8i modules contain a power supply (BDPS) that provides 24 V DC for the circuit boards of the module. The BDPS is powered internally from the DC link. An auxiliary voltage of 230 V AC (standard) or 115 V AC (option +G304) can optionally be fed to X50 (X50:4 and X50:5) to power the BDPS even when the DC link is not live. The 24 V DC voltage provided by the BDPS is available on X53, and can be used to power the control unit of a single R8i inverter module. An output power of 60 W is available from X53.

Note: With an inverter unit consisting of parallel-connected R8i modules, ABB recommends to use an external 24 V DC supply to power the control unit.

If a direct-on-line fan (option +C188) is used, the installer must connect the fan supply (400 V AC 50 Hz or 60 Hz) to the module control connector [X50.1-3]. If an internal heating element (option +C183) is used, the installer must connect the supply for the heating element to the module control connector [X50.7-8].

If the Safe torque off (STO) function is used, STO OUT on the control unit is wired to X52 (STO IN); see the safe torque off function. X51 on the R8i module forwards the STO signals to the X52 connector of the next module (if present).

If the Safe torque off function is not used, the “24V” inputs on X52 must be connected to +24 V (X53, for example) on each inverter module. X51 is to be left unconnected.

Note: As a factory standard, Safe torque off is disabled by a jumper connection between connectors X52 and X53.

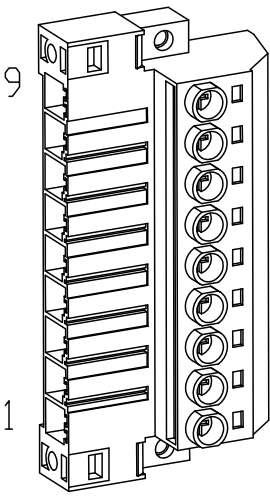
Connector X50		
	9	Not in use.
	8	N
	7	L
	6	Not in use.
	5	N
	4	L
	3	W
	2	V
	1	U
		<p>115/230 V AC (50/60 Hz) input for optional heating element (+C183). The cabinet builder must connect this when the option is in use.</p> <p>Optional 230 V AC 50/60 Hz input for internal power supply (BDPS) (115 V AC 50/60 Hz with option +G304). The cabinet builder can connect this to back up the power supply.¹⁾</p> <p>320 V AC (60 Hz) or 400 V AC (50/60 Hz) supply for optional DOL (direct-online) cooling fan (option +C188). The cabinet builder must connect this when the option is in use.</p> <p>Note: In modules without +C188, the DOL wiring is present but not in use.</p>

- 1) Can be used to:
- Do a communication test while the main circuit of the drive is disconnected and de-energized.
 - Keep the event loggers and buffer memory in operation if the main DC voltage temporarily decreases.

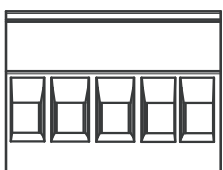
Connectors X51, X52, X53																					
	<table border="1"> <thead> <tr> <th colspan="5">STO OUT</th> </tr> <tr> <th colspan="5">X51</th> </tr> </thead> <tbody> <tr> <td>FE</td> <td>GND</td> <td>24V</td> <td>GND</td> <td>24V</td> </tr> </tbody> </table>			STO OUT					X51					FE	GND	24V	GND	24V	X51	STO OUT	STO signal forwarding output to next inverter module (if present). The cabinet builder must connect this in a unit with parallel modules.
	STO OUT																				
X51																					
FE	GND	24V	GND	24V																	

44 Hardware description

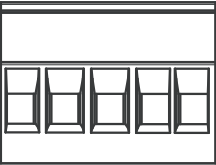
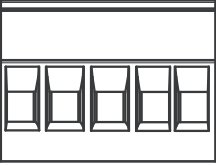
Connectors X51, X52, X53														
	<table border="1"> <thead> <tr> <th colspan="5">STO IN X52</th> </tr> </thead> <tbody> <tr> <td>FE</td> <td>GND</td> <td>24V</td> <td>GND</td> <td>24V</td> </tr> </tbody> </table>	STO IN X52					FE	GND	24V	GND	24V	X52	STO IN	24 V STO signals from the control unit
STO IN X52														
FE	GND	24V	GND	24V										
	<table border="1"> <thead> <tr> <th colspan="5">24V OUT X53</th> </tr> </thead> <tbody> <tr> <td>FE</td> <td>24V</td> <td>GND</td> <td>24V</td> <td>GND</td> </tr> </tbody> </table>	24V OUT X53					FE	24V	GND	24V	GND	X53	24V OUT	24 V DC output (for eg. the control unit)
24V OUT X53														
FE	24V	GND	24V	GND										
<p>Note: The Safe torque off (STO) safety function is only implemented in inverter units. Therefore, the STO function cannot be used in supply, rectifier, DC/DC converter and brake units. In these units, de-energizing any connection of STO IN (X52) connector stops the unit. Note that this stop is not safety related and must not be used for safety function purposes.</p>														

Fiber-optic connectors

		Name	Description
BSFC	V50 V60	BSFC	Charging controller connection. Must be connected by the installer.
BFPS	V30 V40	BFPS	Fan control connection (to fan control box). Connected at the factory.
BCU	V10 V20	BCU, UCU-22...24	Control unit connection. Must be connected by the installer.

Overview circuit diagram of a frame R8i inverter unit

The following figure shows a simplified connection example of an inverter unit based on a single inverter module.

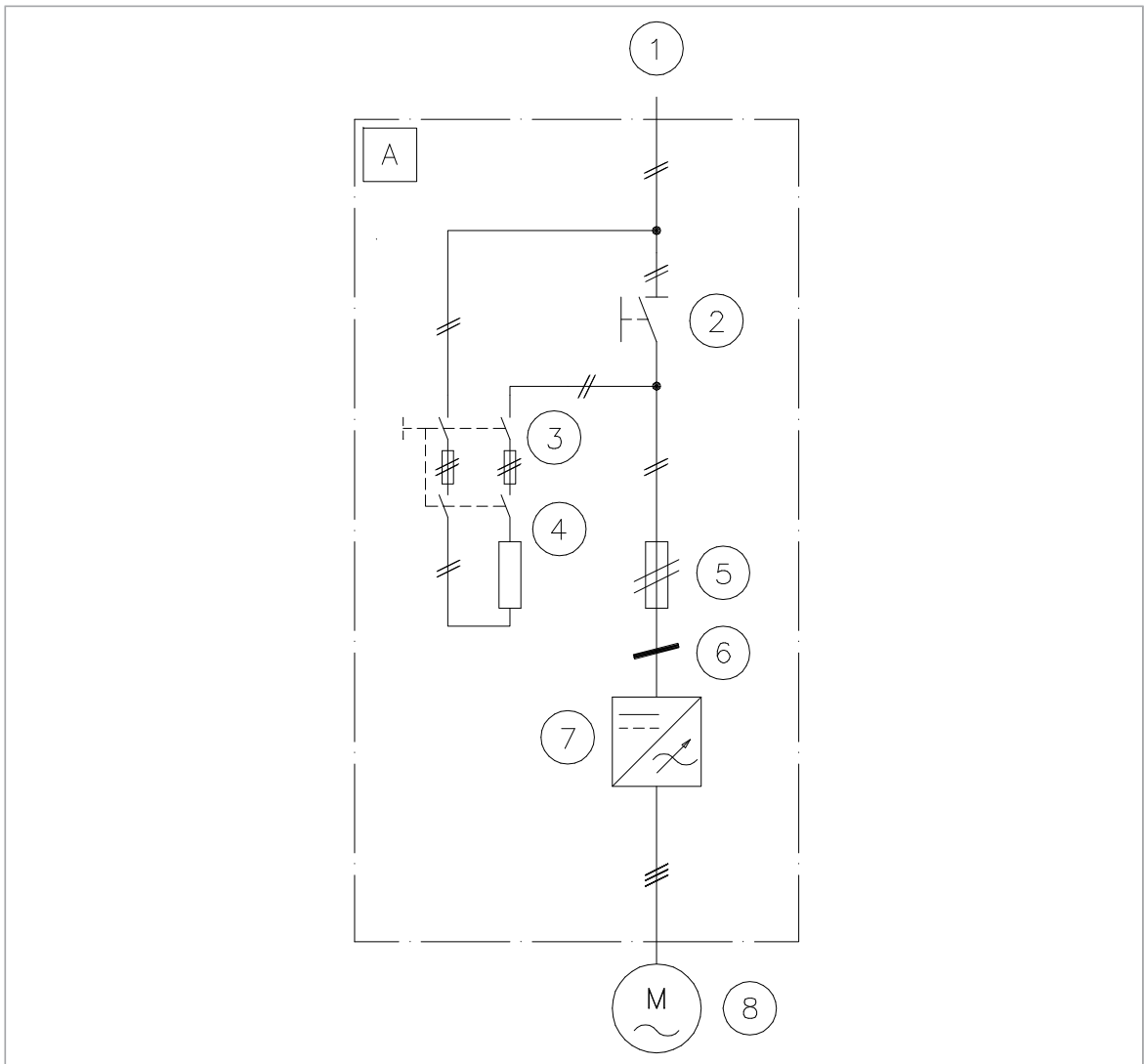

Item	Explanation	Available through
A	Inverter cubicle	-
1	DC supply	-
2	DC switch-disconnector (optional)	ABB or third party
3	Charging switch (optional)	ABB or third party
4	Charging resistor (optional)	ABB or third party
5	DC fuses	ABB or third party
6	Common mode filters	ABB
7	Inverter module	ABB
8	Motor	ABB (not part of ACS880-104LC product offering) or third party

Overview circuit diagram of a frame 2×R8i inverter unit

The following figure shows a simplified connection example of an inverter based on two parallel-connected frame R8i inverter modules.

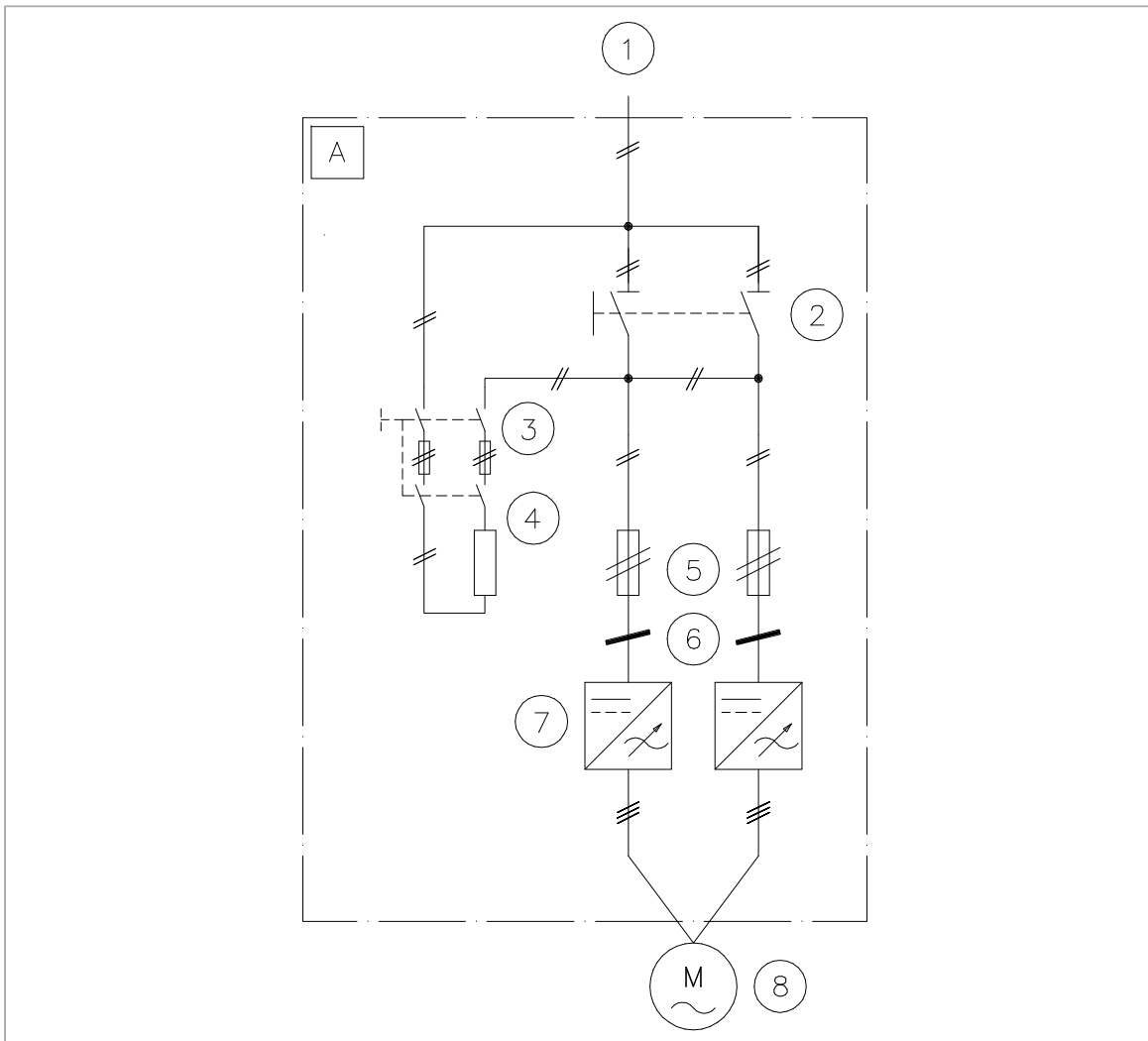

Item	Explanation	Available through
A	Inverter cubicle	-
1	DC supply	-
2	DC switch-disconnector (optional)	ABB or third party
3	Charging switch (optional)	ABB or third party
4	Charging resistors (optional)	ABB or third party
5	DC fuses	ABB or third party
6	Common mode filters	ABB
7	Inverter modules	ABB
8	Motor	ABB (not part of ACS880-104LC product offering) or third party

Cabinet layout and cooling

Refer to chapter [Cabinet construction \(page 55\)](#).

Module variant with capability for increased switching frequency

Module variant with capability for increased switching frequency (option +P967) is also available. The high-speed option is intended for test bench applications with high-speed permanent magnet motors. The option involves installing a BLHF-2x-7 filter to the drive output. Refer to [ACS880 multidrive for high-speed test benches supplement \(3AXD50000818013 \[English\]\)](#).

Inverter unit control interfaces

■ Overview of the control connections of the UCU-22, UCU-23 and UCU-24 control unit

The diagram shows the possible control connections and interfaces of the UCU-22, UCU-23 and UCU-24 control units.

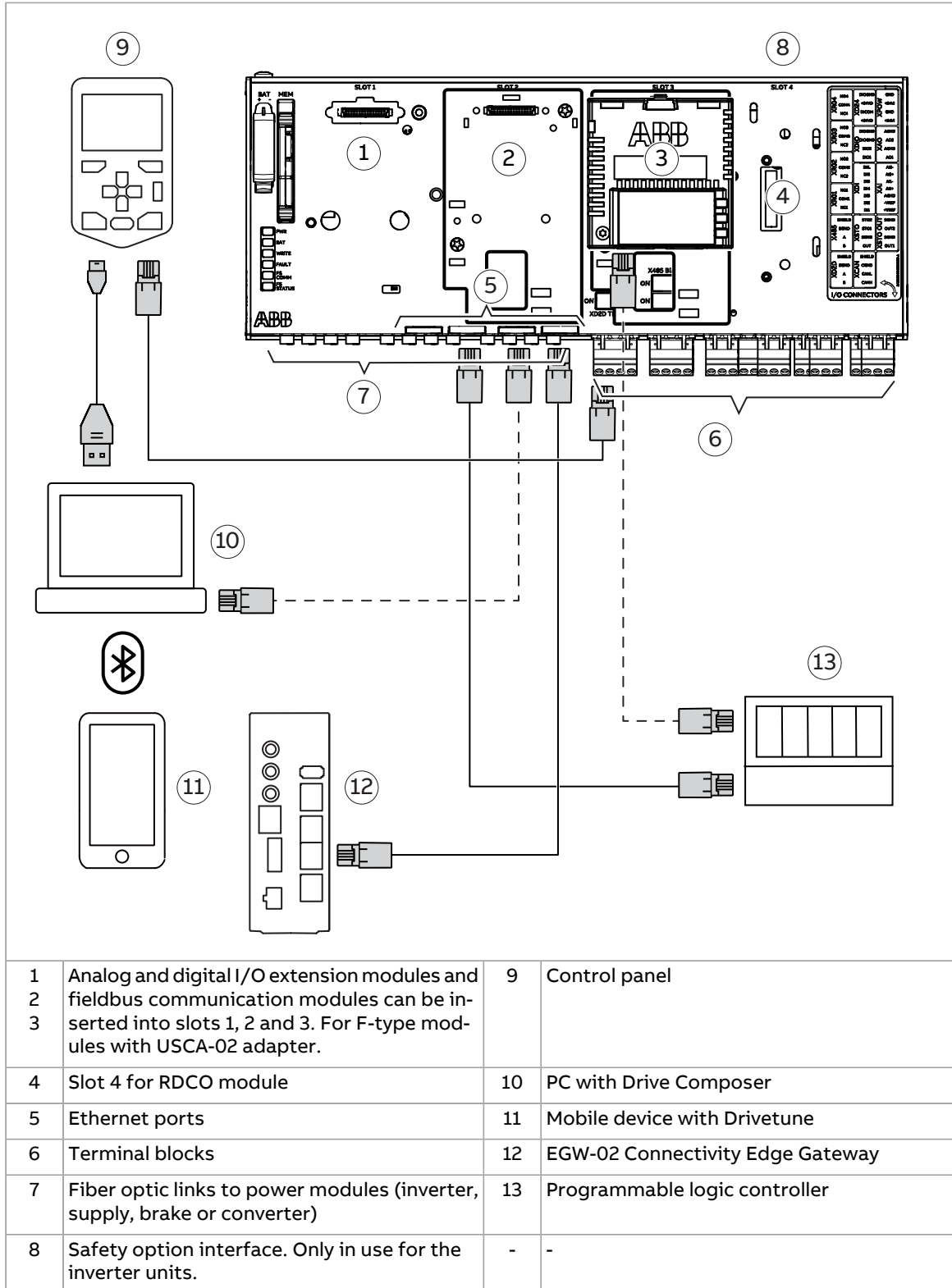

■ **Overview of control connections of the ZCU control unit**

The diagram shows the possible control connections and interfaces of the ZCU-14 control unit.

ZCU-12 has a different layout, but the connections are the same as in ZCU-14.

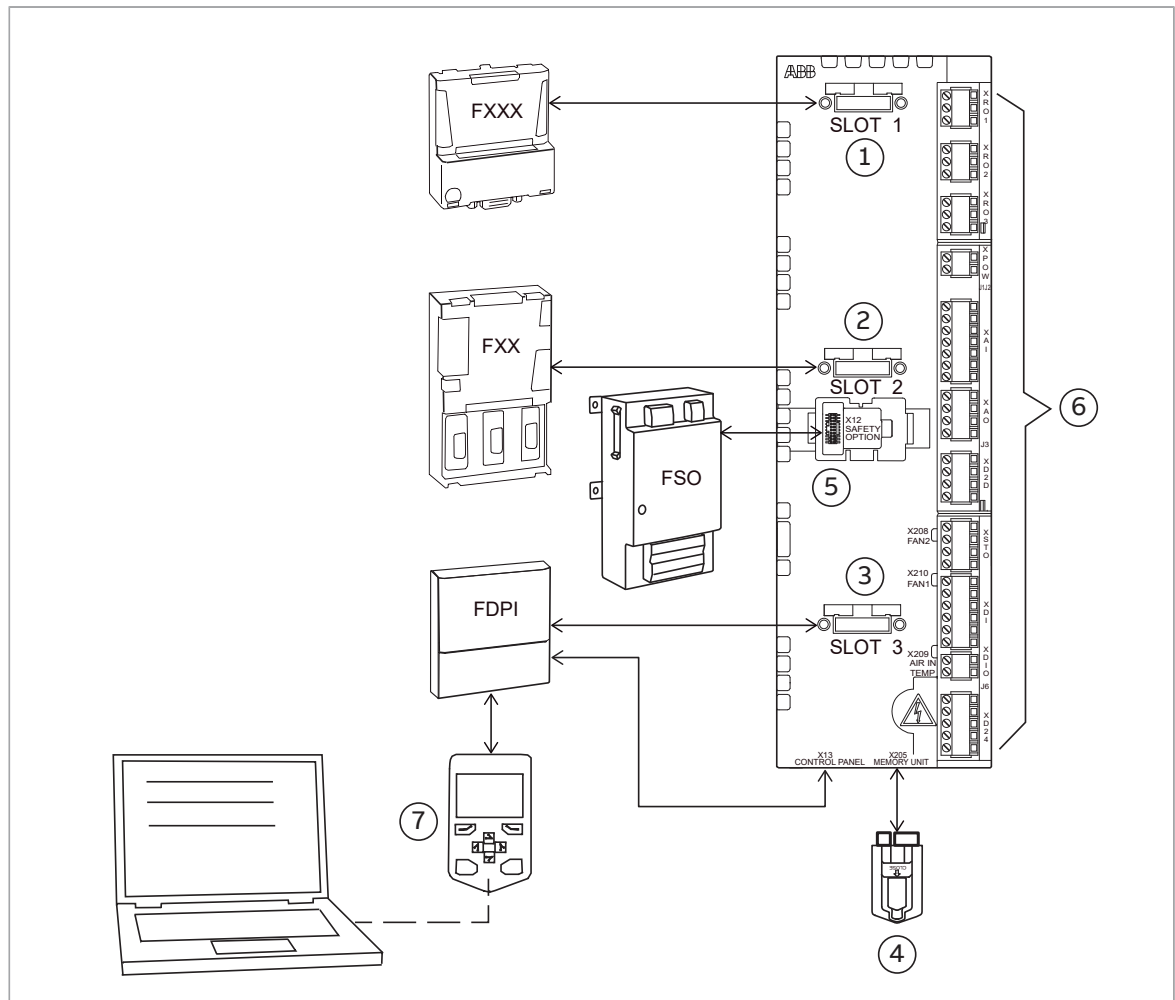

1	Option modules can be inserted into slots 1, 2 and 3 as follows:	
2		
3	Modules	Slots
	Analog and digital I/O extension modules ¹⁾	1, 2, 3
	Feedback interface modules	1, 2, 3
	Fieldbus communication modules	1, 2, 3
	FSO safety functions module	2 (X12)
	1) When installed into slot 3 of a ZCU-14 control unit, the module will extend over the edge. ABB recommends that you use slot 1 or 2 instead whenever possible.	
4	Memory unit	
5	Connector for FSO safety functions module (X12). The module reserves slot 2 when connected.	
6	I/O terminal blocks	
7	Control panel	

■ **Overview of the control connections of the BCU control unit**

The diagram shows the possible control connections, and interfaces of the BCU control unit.

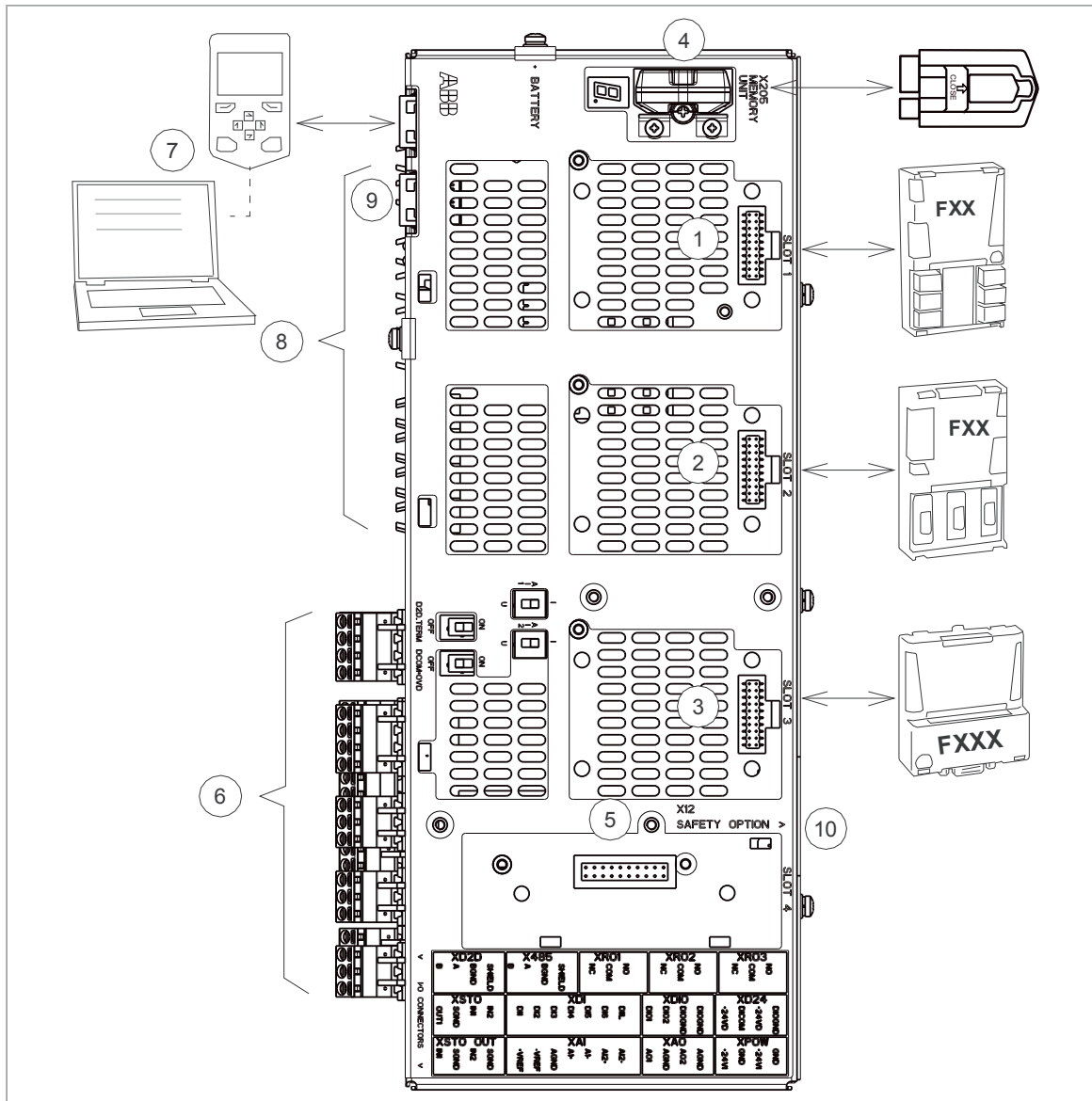

<p>1 Analog and digital I/O extension modules and fieldbus communication modules can be inserted into slots 1, 2 and 3.</p>	<p>7 Control panel</p>
<p>4 Memory unit</p>	<p>8 Fiber optic links to power modules (inverter, supply, brake or converter)</p>
<p>5 Slot 4 for RDCO module</p>	<p>9 Ethernet port. Not in use.</p>
<p>6 Terminal blocks.</p>	<p>10 Safety option interface. Only in use for the inverter units.</p>

■ Control panel

The ACS-AP-W or ACS-AP-I control panel is the user interface of the inverter unit, providing the essential controls such as Start/Stop/Direction/Reset/Reference, and the parameter settings for the control program.

The control panel can be mounted on the cabinet door using a DPMP-01 or DPMP-02 mounting platform (available separately).

With frame R1i...R5i inverter modules, the panel can be mounted on the panel holder on the cover of the module.

One control panel can be used to control several inverter units through a panel link provided that each unit is equipped with panel holder or an FDPI-02 module.

Note: A control panel is required for the commissioning of an ACS880 drive system, even if the Drive Composer PC tool is used.

For details on the control panel, refer to [ACS-AP-I, -S, -W and ACH-AP-H, -W Assistant control panels user's manual \(3AUA0000085685 \[English\]\)](#).

Control by PC tools

There is a USB connector on the front of the panel that can be used to connect a PC to the drive. When a PC is connected to the control panel, the control panel keypad is disabled.

Type designation key

Type designation describes the composition of the module in short. The complete designation code is divided in subcodes:

- The first digits form the basic code. It describes the basic construction of the module. The fields in the basic code are separated by hyphens.
- The plus codes follow the basic code. Each plus code starts with an identifying letter (common for the whole product series), followed by descriptive digits. The plus codes are separated by plus signs.

The subcodes are described below.

Code	Description
Basic codes	
ACS880	Product series
104	Construction: Inverter, supply, converter or brake module.
Size	
xxxxx	Refer to the ratings table in the technical data.
Voltage range	
3	513...566 V DC. This is indicated in the type designation label as typical input voltage level (566 V DC).
5	513...707 V DC. This is indicated in the type designation label as typical input voltage levels (566/679/707 V DC).
7	709...976 V DC. This is indicated in the type designation label as typical input voltage levels (742/849/976 V DC).
Option codes (plus codes)	
C132	Marine type approval
C183	Internal heating element
C188	Direct-on-line (DOL) cooling fan
C249	<u>Frames R6i and R7i</u> : Interface for optical fiber cable connection for the control unit
E205	Internal du/dt filtering
F272	Internal charging circuit
G304	115 V auxiliary voltage supply
N8010	Drive application programming
P942	Retrofit version of frame R8i (mechanically compatible with ACS800 R8i)
P967	Module variant with capability for increased switching frequency
V112	Module auxiliary and fan power supply connector change
V992	<u>Frames R6i and R7i</u> : Hardware version 2

3

Moving and unpacking the module

Contents of this chapter

This chapter gives basic information on moving, unpacking and lifting the modules.

Moving and lifting the transport package

Move the transport package by a pallet truck or lift. Lift the transport package in a horizontal position. Use soft lifting slings.

Unpacking

■ Frames R1i...R5i

The module is delivered in a corrugated cardboard box. The module and its parts (such as grounding/clamp plates, terminal blocks, etc.) are placed in the different compartments of the box.

1. Remove any banding and lift off the cover of the box.
2. Lift the module out of the box.
3. Check all the compartments in the box for accessories.

Note: Some parts may be placed in a compartment directly underneath the module.

Dispose of or recycle the packaging according to the local regulations.

■ Frames R6i...R8i

The module is delivered on a wooden base, boxed in corrugated cardboard. The cardboard box is tied to the base with PET bands.



⚠ WARNING Obey the safety instructions of the drive. If you ignore them, injury or death, or damage to the equipment can occur.

1. Cut off the bands.
2. Lift off the cardboard box.
3. Remove any filling material.
4. Cut open the plastic wrapping of the module.
5. Lift off the module.
6. Check that there are no signs of damage.

Dispose of or recycle the packaging according to the local regulations.

Lifting the unpacked modules

Lift the unpacked module only from its lifting eyes.

Moving the unpacked modules



⚠ WARNING For general safety instructions for moving the module, refer to [ACS880 multidrives cabinets and modules safety instructions \(3AUA0000102301 \[English\]\)](#).

4

Cabinet construction



Contents of this chapter

This chapter gives instructions on how to install the modules and other equipment into a cabinet.

For general instructions, refer to [Drive modules cabinet design and construction instructions \(3AUA0000107668 \[English\]\)](#).

Limitation of liability

The installation must always be designed and made according to applicable local laws and regulations. ABB does not assume any liability whatsoever for any installation that breaches the local laws and/or other regulations. Furthermore, if the recommendations given by ABB are not followed, the drive may experience problems that the warranty does not cover.

■ North America

Installations must be compliant with NFPA 70 (NEC)¹⁾ and/or Canadian Electrical Code (CE code), along with state and local codes for your location and application.

¹⁾ National Fire Protection Association 70 (National Electric Code).

General

Refer to the technical data for module-specific cooling requirements and allowed mounting orientations.

Configuration overviews of the inverter module cubicles

This section shows configuration examples of the inverter module cubicles with DC switches.

If you use VX25 Rittal cabinets, you can make configurations with no more than two R8i modules in one cubicle.

For more information, refer to [Drive modules cabinet design and construction instructions \(3AUA0000107668 \[English\]\)](#).

The values in the images show the width of the cubicle in millimeters.

■ **Frame sizes R1i...R7i**

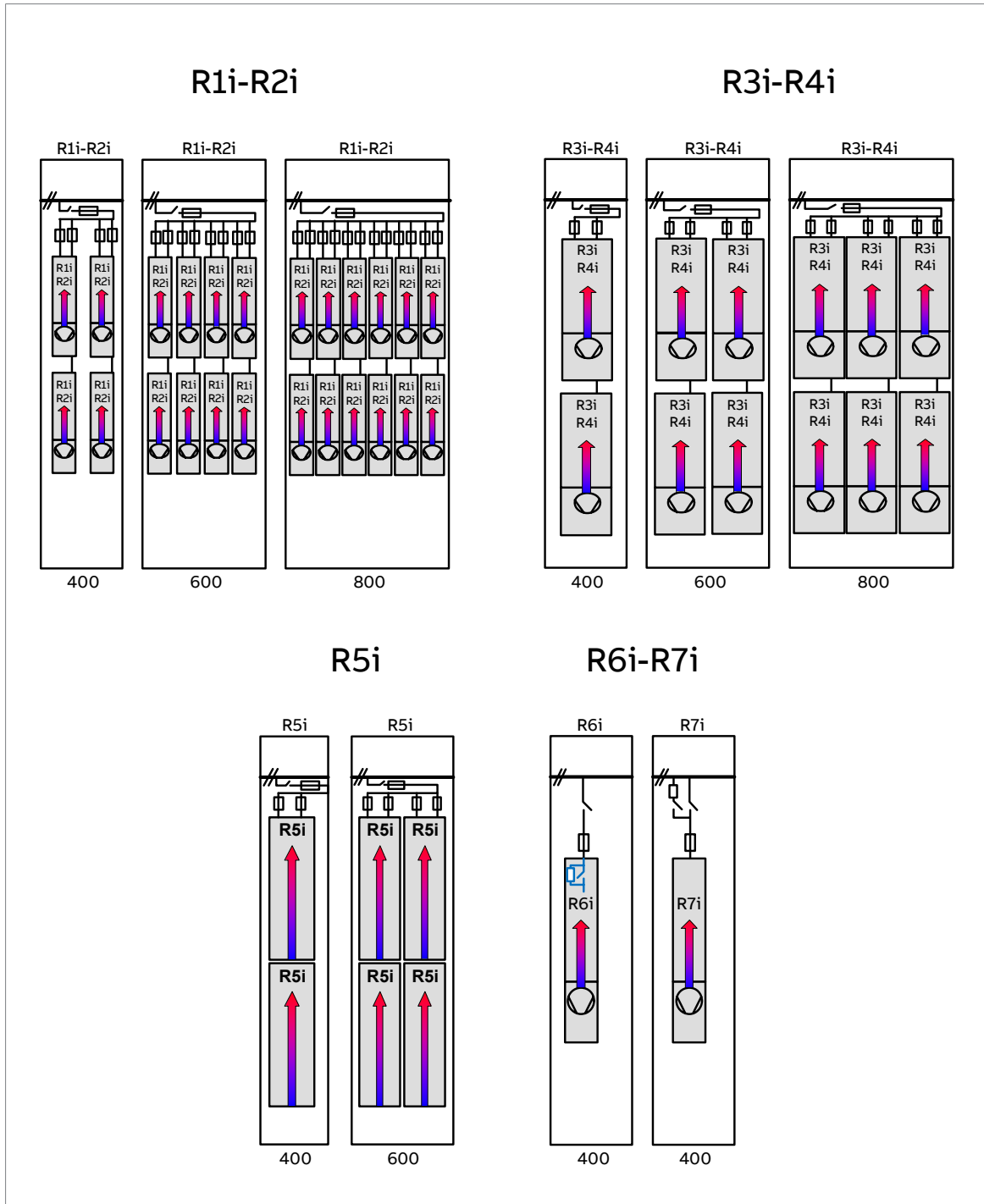

■ Frame sizes R8i and multiples, IEC installations in generic cabinets

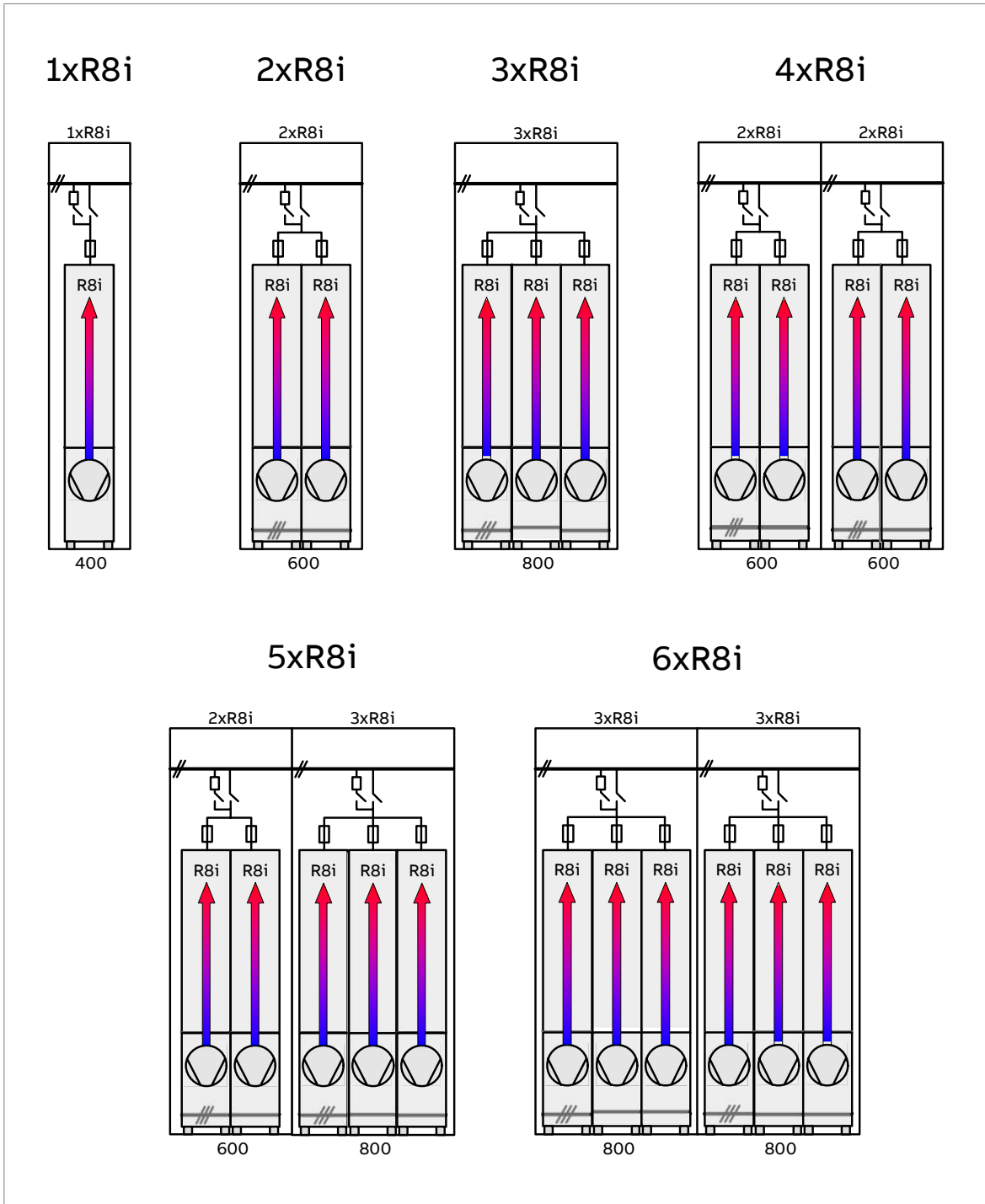

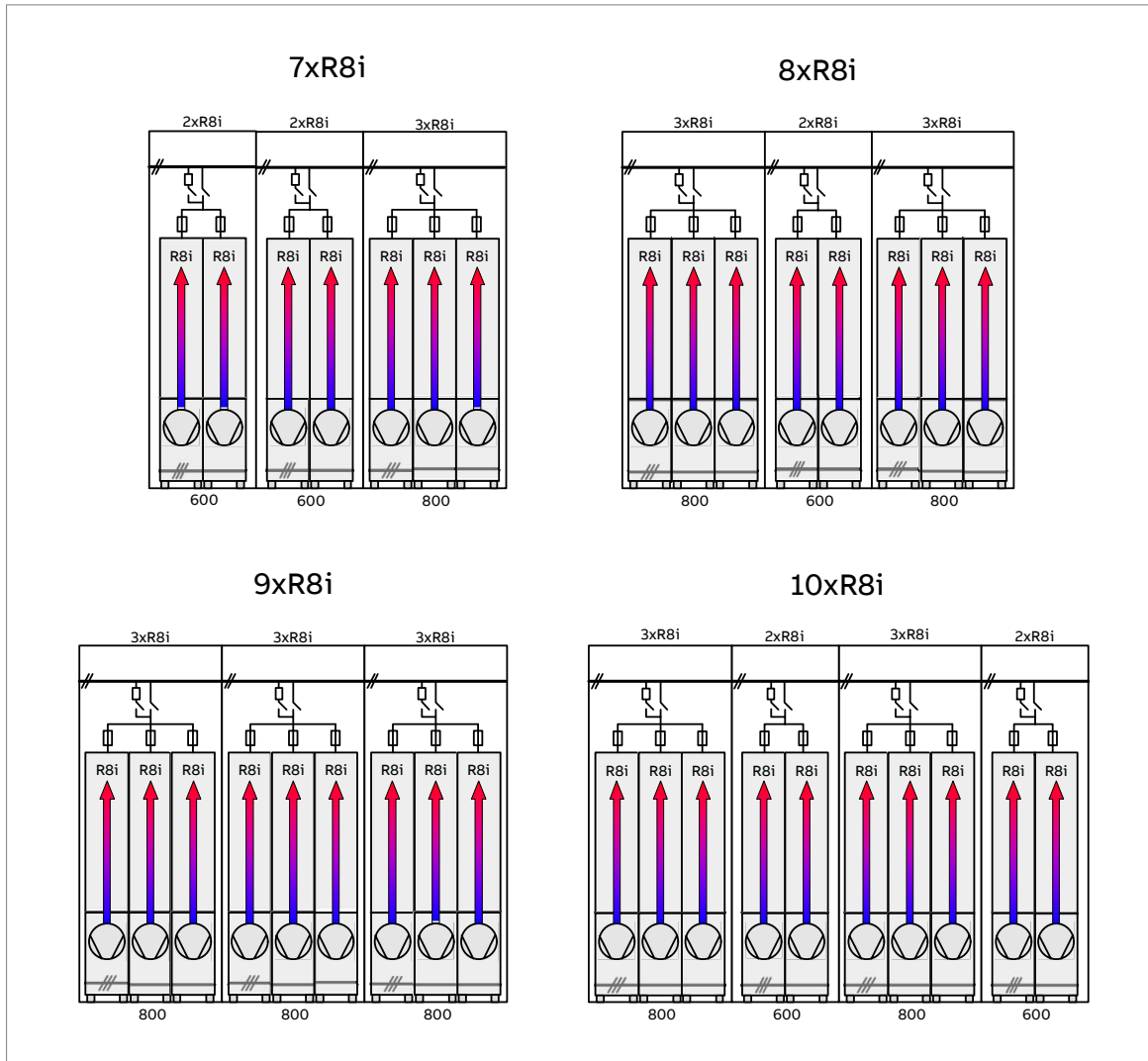

■ **Frame sizes R8i and multiples, IEC and UL installations in VX25 Rittal cabinets**

NOTICE If you have five or more 400 V or 500 V frame size R8i modules, or six or more 690 V frame size R8i modules, it is possible that the total load is more than the maximum current-carrying capacity of the Rittal Flat-PLS60 busbars. In such conditions, divide the DC power supply into two separate paths. To do this, install two supply units with one on the left side and one on the right side of the inverter unit. Alternatively, divide the cubicles of the inverter unit to the left side and right side of the supply unit.

Contact ABB for more information.

1xR8i

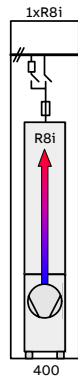

2xR8i

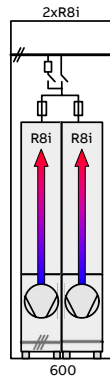

3xR8i

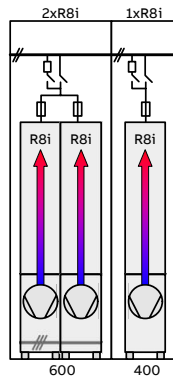

4xR8i

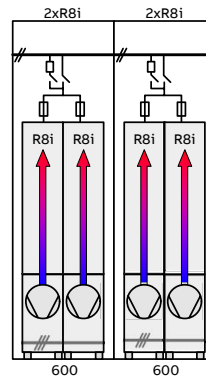

5xR8i

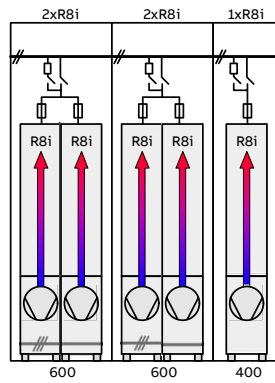

6xR8i

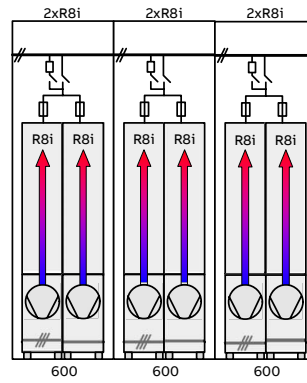

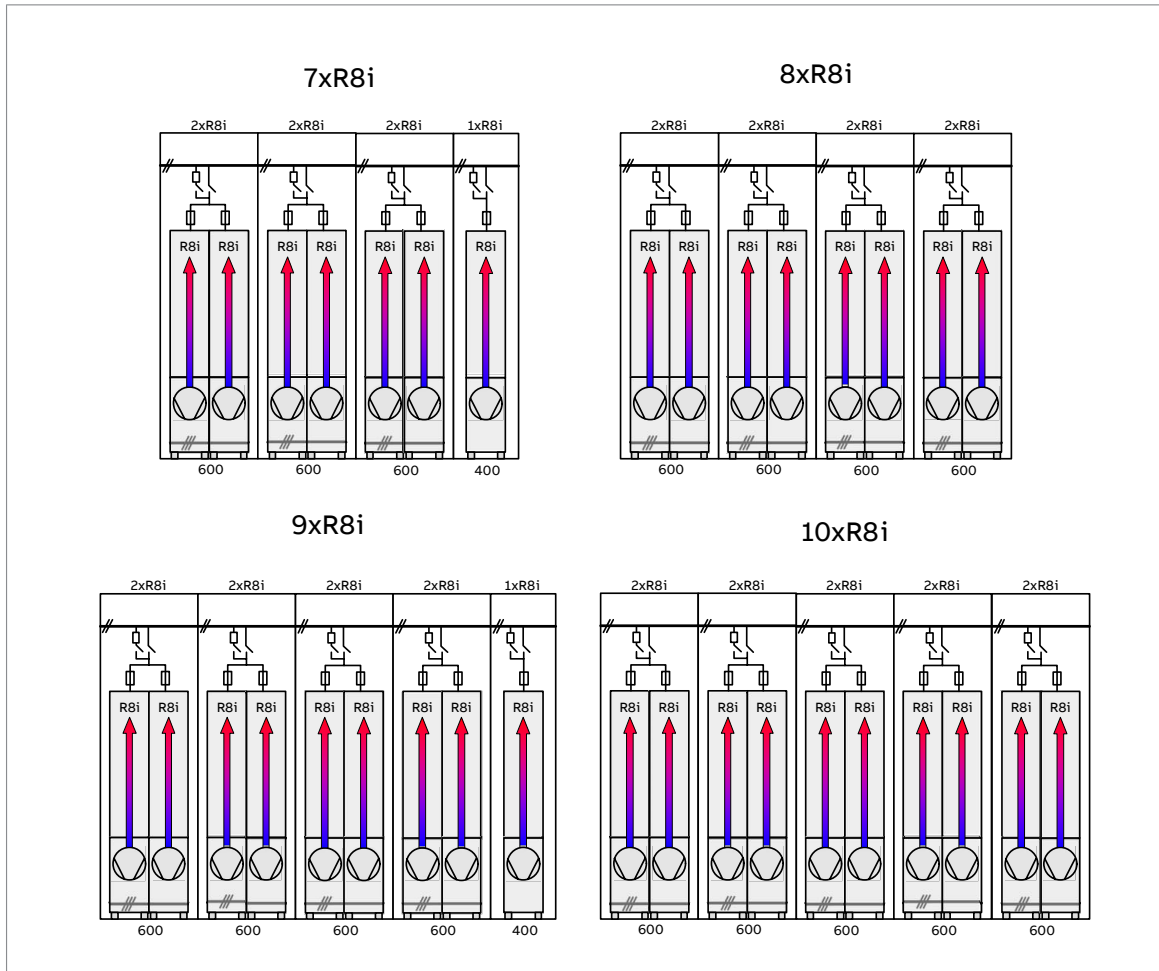

Installation examples

This section contains cabinet construction examples. Each example presents the cubicle with the power modules and related main circuit components. These examples do not show the installation and connections of the control unit, or other components in the control circuit or auxiliary power supply circuit.

Each example includes a table with:

- installation stages of the different equipment in the correct installation order
- instruction code of the step-by-step instructions
- equipment kit code
- kit ordering code.

For the kit-specific assembly drawings, step-by-step instructions and kit information, go to <https://sites-apps.abb.com/sites/lvacdrivesengineeringssupport/content>. If necessary, contact your local ABB representative.

The example includes cabinet assembly drawings that show each stage listed in the table. More detailed steps of each stage are described in the kit-specific assembly drawings. The tightening torques are listed in the kit-specific assembly drawings and in the technical data in the hardware manual.

For general instructions, refer to [Drive modules cabinet design and construction instructions \(3AUA0000107668 \[English\]\)](#).

NOTICE Remove the code labels attached to mechanical parts such as busbars, shrouds and sheet metal parts before installation. They can cause bad electrical connections, or, after peeling off and collecting dust in time, cause arcing or block the cooling air flow.



■ **R1i...R4i modules in a 400 mm wide Rittal VX25 enclosure**

A maximum of four frame R1i or R2i modules, or two frame R3i or R4i modules can be fitted into a 400 mm wide VX25 enclosure, but the number can be reduced by optional equipment.

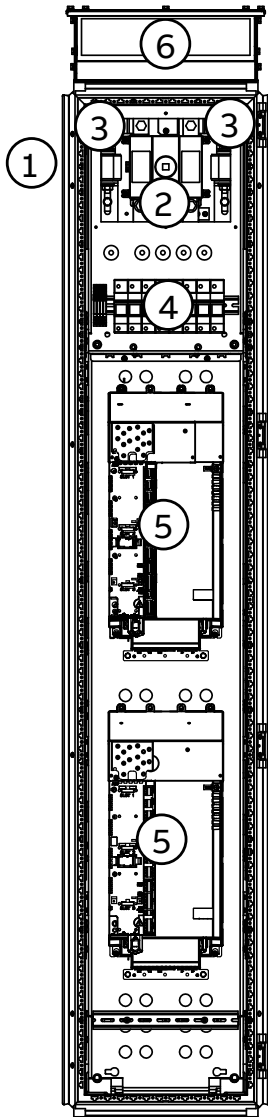

1	DC input
2	DC switch/disconnector for all inverter modules
3	Main DC fuses
4	DC fuse disconnectors for each inverter module
5	Inverter modules
6	Air outlet with exhaust fan



Installation stages

#	Installation stage	Instruction code	Kit code	Kit ordering code
1	Common parts:			
	Baying parts	3AXD50000336340	-	-
	PE busbars	3AXD50000336104	-	-
	Divider panel	3AXD50000336692	-	-
	DC bus support kit	3AXD50000333639	A-468-X-001-VX	3AXD50000333387
2	Bottom plate	-	-	-
3	Mounting plate (IEC)	3AXD50000444588	-	-
	Mounting plate (UL)	3AXD50000003890	-	-
4	DC busbars (IEC)	3AXD50000453108	A-4-1234-272-VX	3AXD50000474493
	DC busbars (UL)	3AXD50000003895	A-4-1234-274	3AXD50000003918
5	Mounting plate shrouds	3AXD50000450060	A-4-1234-403-VX	3AXD50000456772
6	Inverter modules and air guides:			
	R1i	3AUA0000114397	A-468-1-422	3AUA0000114398
	R2i	3AUA0000114397	A-468-2-423	3AUA0000114330
	R3i	3AUA0000114397	A-468-3-424	3AUA0000114404
	R4i	3AUA0000114397	A-468-4-425	3AUA0000114405
7	du/dt filters	3AXD50000458721	-	See AC-side components (page 286)



Overview of kits



1	2	3	4	5	6	7	8
<p>3AXD50000460755 A.01 We reserve all rights for this document and in the information contained herein. Reproduction, storage in retrieval systems, copying, distribution, or any other use is strictly forbidden. © ABB. ALL INFORMATION CONTAINED HEREIN IS UNCLASSIFIED.</p> <p>A Initial Approval 23-May-19 M. Michelsson</p>							
<p>KITS FOR INU R1i-R4i IN RITTAL VX25 2000x600x400 CABINET</p> <p>Note! Only parts included in ABB kits are shown here. See kit assembly drawings for required Rittal and/or other standard parts.</p>							
<p>AIR OUTLET FORCED W400</p>							
<p>BRACKET FOR FLAT-PLUS BUSBAR HOLDER (COMMON DC) KIT A-468-X-001-VX Ordering code: 3AXD50000333387</p>							
<p>MOUNTING PLATE SHROUDS FOR W400 KIT A-4-1234-403-VX Ordering code: 3AXD50000456772</p>							
<p>BUSBARS FOR DC DISTRIBUTION W400 KIT A-4-1234-272-VX (UL: KIT A-4-1234-274) Ordering code: 3AXD50000474493 (UL: 3AXD50000003918)</p>							
<p>AIR GUIDE FOR MODULE KITS KIT A-468-1-422 (3AXD0000114398) for R1i KIT A-468-2-423 (3AXD0000114330) for R2i KIT A-468-3-424 (3AXD0000114404) for R3i KIT A-468-4-425 (3AXD0000114405) for R4i</p>							

Prepared	M. Michelsson	23-May-19	Title	ASSEMBLY DRAWING	Scale	Form
Check.	M. Michelsson	23-May-19	ACS880-104-R1i-R4i-W400	ASSEMBLY DRAWING	7:100	A3
Appr.	M. Asikainen	23-May-19	FOR RITTAL VX25	Rev. ind.	A.0 (DB)	Lang. EN
Project name				Doc. No.	3AXD50000460755	
DWG Number	3AXD10000935852			Sheet	3	
Weight kg				Total	3	



Stage 1: Installation of common parts

1	2	3	4	5	6	7	8
<p>3AXD5000046755 ACS880-04-3124-W400-V125-CAS5-M10+</p>							
<p>WE RESERVE ALL RIGHTS IN THIS DOCUMENT AND IN THE INFORMATION CONTAINED HEREIN. REPRODUCTION, STORAGE, RETRIEVAL, TRANSMISSION, OR ANY INFORMATION SYSTEM, WITHOUT EXPRESS WRITTEN PERMISSION, IS STRICTLY FORBIDDEN.</p>							
<p>DATE OF PREPARATION AND ISSUE INFORMATION: CONFIDENTIAL</p>							
<p>Initial Approval: 23-May-19 M. Michelsson</p>							
<p>Note! See general engineering cabinet manual for common assembly principles</p> <p>STAGE 1: Common assembly installations (Baying parts, PE bus bar, Divider panel, and Common DC). See assembly drawings for details</p>							
<p>Baying parts assembly See drawing 3AXD50000336340</p> <p>Divider panel assembly See drawing 3AXD50000336692</p> <p>Common DC Flat-PLS assembly See drawing 3AXD50000336339</p> <p>PE bus bar design See drawing 3AXD50000336104</p>							
<p>Based on: Prepared by: M. Michelsson 23-May-19 Title: ASSEMBLY DRAWING</p> <p>Checked by: M. Michelsson 23-May-19 Sub title: ASSEMBLY DRAWING</p> <p>Drawn by: M. Michelsson 23-May-19 Part name: COMMON PARTIAL V125</p> <p>Customer: 3AXD10000303882 Project name: Weight: kg</p> <p>DMS Number: 3AXD5000046755</p>							
<p>Doc. No. 3AXD5000046755</p> <p>Rev. No. 3AXD5000046755</p> <p>Doc. Title: ASSEMBLY DRAWING</p> <p>Rev. Title: ASSEMBLY DRAWING</p> <p>Doc. No.: 3AXD5000046755</p> <p>Rev. No.: 3AXD5000046755</p>							
<p>ABB</p>							





Stage 2: Installation of bottom plate

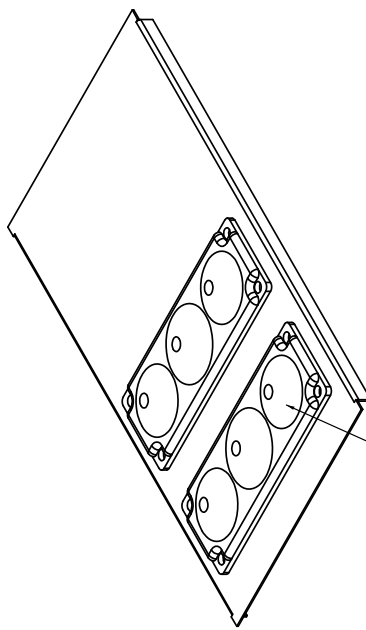
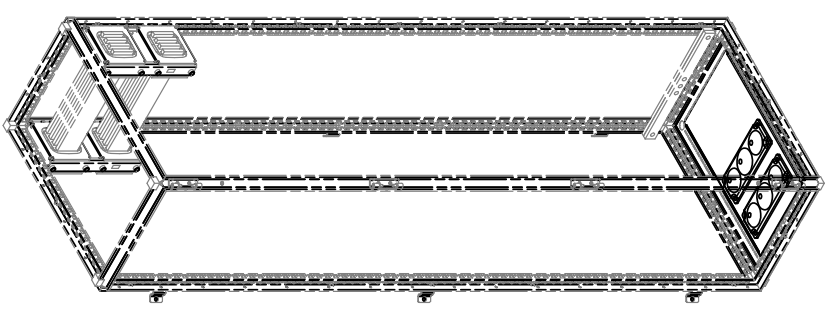

1	2	3	4	5	6	7	8																																																																														
<p>3AXD50000460755</p> <p>A.01</p> <p>AC5880-104-R14-W400-VZ25-LSSE-M117*</p> <p>Initial Approval</p> <p>23-May-19 M. Michelsson</p>																																																																																					
<p>2</p> <p>3</p> <p>4</p> <p>5</p> <p>6</p> <p>7</p> <p>8</p>																																																																																					
<p>STAGE 2: Bottom Plate installation (if applicable)</p> <p>Note! EMC cable lead-throughs should be used (not included in ABB delivery)</p>																																																																																					
 <p>Cable lead-throughs not included in kit</p>																																																																																					
<p>First angle projection. Original drawing made with 3D CAD. Set the correct scale factor when adding dimensions after DWG/DXF conversion.</p>																																																																																					
<table border="1" style="width: 100%; border-collapse: collapse;"> <tr> <td style="width: 20%;">Based on</td> <td style="width: 20%;">M. Michelsson</td> <td style="width: 20%;">23-May-19</td> <td style="width: 20%;">Title</td> <td style="width: 10%;">ASSEMBLY DRAWING</td> <td style="width: 10%;">Scale</td> <td style="width: 10%;">1:10</td> <td style="width: 10%;">Form</td> <td style="width: 10%;">A3</td> </tr> <tr> <td>Customer</td> <td>M. Michelsson</td> <td>23-May-19</td> <td>ACS880-104-R11-R41-W400</td> <td>ASSEMBLY DRAWING</td> <td>1:10</td> <td></td> <td></td> <td></td> </tr> <tr> <td>Appr.</td> <td>M. Asikainen</td> <td>23-May-19</td> <td>FOR RITTAL VZ25</td> <td>Rev.ind.</td> <td>A.0 (DB)</td> <td></td> <td></td> <td></td> </tr> <tr> <td>Doc. No.</td> <td>3AXD50000460755</td> <td></td> <td></td> <td>Doc. des.</td> <td></td> <td></td> <td></td> <td></td> </tr> <tr> <td>Proj. name</td> <td></td> <td></td> <td></td> <td>Resp. dept.</td> <td></td> <td></td> <td></td> <td></td> </tr> <tr> <td>Weight kg</td> <td></td> <td></td> <td></td> <td>Doc. No.</td> <td>3AXD50000460755</td> <td></td> <td></td> <td></td> </tr> <tr> <td colspan="4"></td> <td colspan="4" style="text-align: center;">ABB</td> </tr> <tr> <td colspan="4"></td> <td colspan="4" style="text-align: center;"> <table border="1" style="width: 100%; border-collapse: collapse;"> <tr> <td>Form</td> <td>A3</td> </tr> <tr> <td>Lang.</td> <td>EN</td> </tr> <tr> <td>Sheet</td> <td>3</td> </tr> <tr> <td>Total</td> <td>3</td> </tr> </table> </td> </tr> </table>								Based on	M. Michelsson	23-May-19	Title	ASSEMBLY DRAWING	Scale	1:10	Form	A3	Customer	M. Michelsson	23-May-19	ACS880-104-R11-R41-W400	ASSEMBLY DRAWING	1:10				Appr.	M. Asikainen	23-May-19	FOR RITTAL VZ25	Rev.ind.	A.0 (DB)				Doc. No.	3AXD50000460755			Doc. des.					Proj. name				Resp. dept.					Weight kg				Doc. No.	3AXD50000460755								ABB								<table border="1" style="width: 100%; border-collapse: collapse;"> <tr> <td>Form</td> <td>A3</td> </tr> <tr> <td>Lang.</td> <td>EN</td> </tr> <tr> <td>Sheet</td> <td>3</td> </tr> <tr> <td>Total</td> <td>3</td> </tr> </table>				Form	A3	Lang.	EN	Sheet	3	Total	3
Based on	M. Michelsson	23-May-19	Title	ASSEMBLY DRAWING	Scale	1:10	Form	A3																																																																													
Customer	M. Michelsson	23-May-19	ACS880-104-R11-R41-W400	ASSEMBLY DRAWING	1:10																																																																																
Appr.	M. Asikainen	23-May-19	FOR RITTAL VZ25	Rev.ind.	A.0 (DB)																																																																																
Doc. No.	3AXD50000460755			Doc. des.																																																																																	
Proj. name				Resp. dept.																																																																																	
Weight kg				Doc. No.	3AXD50000460755																																																																																
				ABB																																																																																	
				<table border="1" style="width: 100%; border-collapse: collapse;"> <tr> <td>Form</td> <td>A3</td> </tr> <tr> <td>Lang.</td> <td>EN</td> </tr> <tr> <td>Sheet</td> <td>3</td> </tr> <tr> <td>Total</td> <td>3</td> </tr> </table>				Form	A3	Lang.	EN	Sheet	3	Total	3																																																																						
Form	A3																																																																																				
Lang.	EN																																																																																				
Sheet	3																																																																																				
Total	3																																																																																				

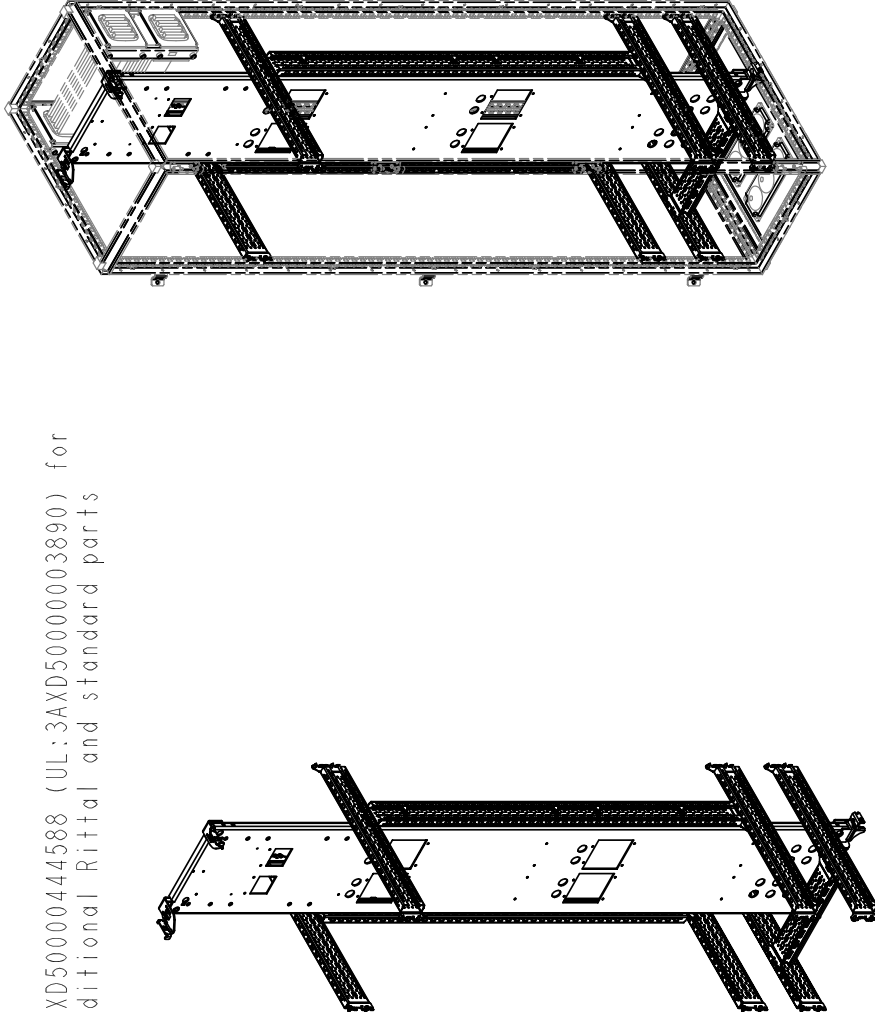
Stage 3: Installation of mounting plate

1	2	3	4	5	6	7	8
<p>3AXD5000046755 ACS880-04-B104-W400-V1Z5-CAS5-M1171</p> <p>WE EXCEPT ALL RIGHTS IN THIS DOCUMENT AND IN THE INFORMATION CONTAINED HEREIN. REPRODUCTION, USE OR DISSEMINATION OF THIS DOCUMENT OR THE INFORMATION CONTAINED HEREIN WITHOUT EXPRESS WRITTEN PERMISSION IS STRICTLY FORBIDDEN.</p> <p>ABB CORPORATION, PROPRIETARY AND SECRET INFORMATION. CONFIDENTIAL</p> <p>23-May-19 M. Michelsson</p> <p>Initial Approval</p>							
<p>First angle projection. Original drawing made with 3D CAD. Set the correct scale factor when adding dimensions after DWG/DXF conversion.</p>							
A	B	C	D	E	F		
<p>STAGE 3: Mounting plate for W400 installation</p> <p>See assembly drawing 3AXD5000044588 (UL:3AXD5000003890) for details and required additional Rittal and standard parts</p>							
							
Based on:		Prepared:	M. Michelsson	23-May-19	Title: ASSEMBLY DRAWING		
Customer:		Checked:	M. Michelsson	23-May-19	Doc. No.: 3AXD5000046755		
DMS Number:		Drawn:	M. Michelsson	23-May-19	Rev. No.: 04		
		Project name:	3AXD10000303882	23-May-19	Rev. No.: 01		
		Weight:	kg		Rev. No.: 02		
					Rev. No.: 03		
					Rev. No.: 04		
					Rev. No.: 05		
					Rev. No.: 06		
					Rev. No.: 07		
					Rev. No.: 08		
					Rev. No.: 09		
					Rev. No.: 10		
					Rev. No.: 11		
					Rev. No.: 12		
					Rev. No.: 13		
					Rev. No.: 14		
					Rev. No.: 15		
					Rev. No.: 16		
					Rev. No.: 17		
					Rev. No.: 18		
					Rev. No.: 19		
					Rev. No.: 20		
					Rev. No.: 21		
					Rev. No.: 22		
					Rev. No.: 23		
					Rev. No.: 24		
					Rev. No.: 25		
					Rev. No.: 26		
					Rev. No.: 27		
					Rev. No.: 28		
					Rev. No.: 29		
					Rev. No.: 30		
					Rev. No.: 31		
					Rev. No.: 32		
					Rev. No.: 33		
					Rev. No.: 34		
					Rev. No.: 35		
					Rev. No.: 36		
					Rev. No.: 37		
					Rev. No.: 38		
					Rev. No.: 39		
					Rev. No.: 40		
					Rev. No.: 41		
					Rev. No.: 42		
					Rev. No.: 43		
					Rev. No.: 44		
					Rev. No.: 45		
					Rev. No.: 46		
					Rev. No.: 47		
					Rev. No.: 48		
					Rev. No.: 49		
					Rev. No.: 50		





Stage 4: Installation of DC busbars

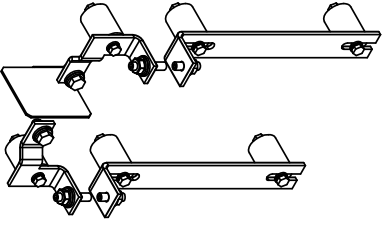
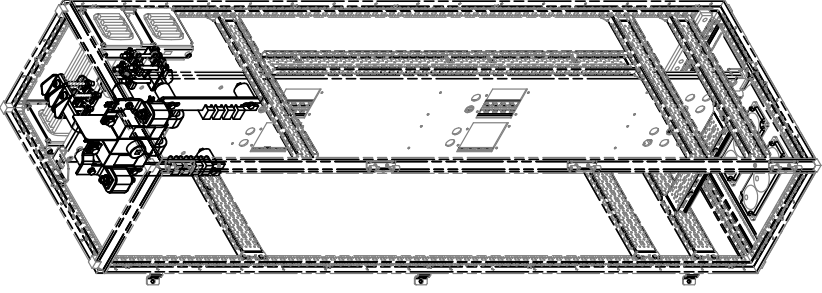

1	2	3	4	5	6	7	8																																																																																								
<p>3AXD50000460755</p> <p>A.01</p> <p>AC5880-104-R184-W400-VZ25_LASSEML17*</p> <p>Initial Approval</p> <p>23-May-19 M. Michelsson</p>																																																																																															
<p>3AXD50000460755</p> <p>AC5880-104-R184-W400-VZ25_LASSEML17*</p> <p>First angle projection. Original drawing made with 3D CAD. Set the correct scale factor when adding dimensions after DWG/DXF conversion.</p>																																																																																															
<p>STAGE 4: Busbars for DC distribution W400 installation</p> <p>See assembly drawing 3AXD50000453108 (UL:3AXD50000003895) for details and required additional Rittal and standard parts</p>																																																																																															
																																																																																															
<p>Ordering code: 3AXD50000474493 KIT A-4-1234-272-VX</p> <p>UL: Ordering code: 3AXD50000003918 KIT A-4-1234-274</p>																																																																																															
																																																																																															
<table border="1" style="width: 100%; border-collapse: collapse;"> <tr> <td style="width: 30%;">Based on</td> <td style="width: 20%;">Prepared</td> <td style="width: 20%;">M. Michelsson</td> <td style="width: 20%;">23-May-19</td> <td style="width: 20%;">Title</td> <td style="width: 10%;">ASSEMBLY DRAWING</td> <td style="width: 10%;">Scale</td> <td style="width: 10%;">Form</td> </tr> <tr> <td>Customer</td> <td>Check.</td> <td>M. Michelsson</td> <td>23-May-19</td> <td>AC5880-104-R11-R41-W400</td> <td>ASSEMBLY DRAWING</td> <td>1:10</td> <td>A3</td> </tr> <tr> <td></td> <td>Appr.</td> <td>M. Asikainen</td> <td>23-May-19</td> <td>FOR RITTAL VZ25</td> <td></td> <td></td> <td></td> </tr> <tr> <td>Proj. No.</td> <td>Project name</td> <td colspan="6"></td> </tr> <tr> <td>DWG Number</td> <td>Weight kg</td> <td colspan="6"></td> </tr> <tr> <td></td> <td></td> <td colspan="6" style="text-align: center;">ABB</td> </tr> <tr> <td></td> <td></td> <td colspan="6">Doc. No. 3AXD50000460755</td> </tr> <tr> <td></td> <td></td> <td colspan="6">Res. Dept. A.0 (DB)</td> </tr> <tr> <td></td> <td></td> <td colspan="6">Lang. EN</td> </tr> <tr> <td></td> <td></td> <td colspan="6">Sheet 5</td> </tr> <tr> <td></td> <td></td> <td colspan="6">Total 8</td> </tr> </table>								Based on	Prepared	M. Michelsson	23-May-19	Title	ASSEMBLY DRAWING	Scale	Form	Customer	Check.	M. Michelsson	23-May-19	AC5880-104-R11-R41-W400	ASSEMBLY DRAWING	1:10	A3		Appr.	M. Asikainen	23-May-19	FOR RITTAL VZ25				Proj. No.	Project name							DWG Number	Weight kg									ABB								Doc. No. 3AXD50000460755								Res. Dept. A.0 (DB)								Lang. EN								Sheet 5								Total 8					
Based on	Prepared	M. Michelsson	23-May-19	Title	ASSEMBLY DRAWING	Scale	Form																																																																																								
Customer	Check.	M. Michelsson	23-May-19	AC5880-104-R11-R41-W400	ASSEMBLY DRAWING	1:10	A3																																																																																								
	Appr.	M. Asikainen	23-May-19	FOR RITTAL VZ25																																																																																											
Proj. No.	Project name																																																																																														
DWG Number	Weight kg																																																																																														
		ABB																																																																																													
		Doc. No. 3AXD50000460755																																																																																													
		Res. Dept. A.0 (DB)																																																																																													
		Lang. EN																																																																																													
		Sheet 5																																																																																													
		Total 8																																																																																													

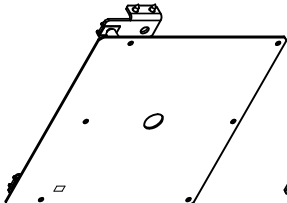
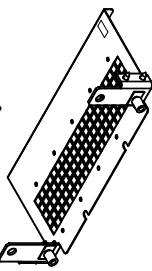
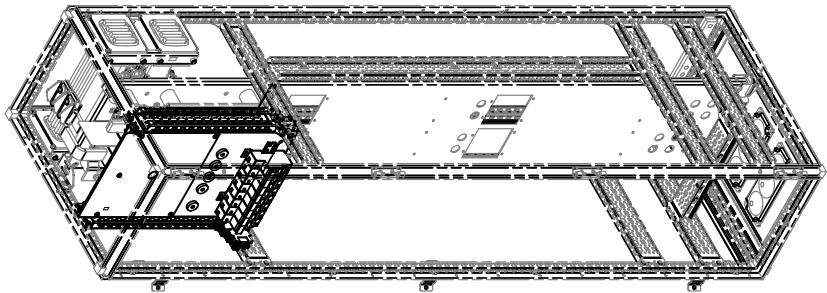
Stage 5: Installation of mounting plate shrouds

1	2	3	4	5	6	7	8
<p>3AXD5000046772 ACS880-04-3124-W400-VX25-CLASS1171 Initial Approval</p>							
<p>2. We reserve all rights in this document and in the information contained herein. Reproduction, use or disclosure of this document without express written authority is strictly forbidden. © ABB CORPORATION AND SECTIA CORPORATION, CONFIDENTIAL</p>							
<p>Prepared by: M. Michelsson Checked by: M. Michelsson Approved by: M. Michelsson Date: 23-May-19 M. Michelsson</p>							
<p>STAGE 5: Mounting plate shrouds for W400 installation</p> <p>See assembly drawing 3AXD50000450060 for details and required additional Rittal and standard parts</p>							
							
							
<p>Based on: M. Michelsson Customer: M. Michelsson CUST. Doc. No.: M. Michelsson DNS Number: 3AXD10000303882 Weight: kg</p>							
<p>Doc. No.: 3AXD5000046772 Title: ASSEMBLY DRAWING FOR RITTAL VX25 Date: 23-May-19 M. Michelsson</p>							
<p>Doc. No.: 3AXD5000046772 Title: ASSEMBLY DRAWING FOR RITTAL W400 Date: 23-May-19 M. Michelsson</p>							
<p>Scale: 1:1 Form: A3 Date: 23-May-19 M. Michelsson</p>							
<p>Doc. No.: 3AXD5000046772 Title: ASSEMBLY DRAWING FOR RITTAL W400 Date: 23-May-19 M. Michelsson</p>							
<p>Doc. No.: 3AXD5000046772 Title: ASSEMBLY DRAWING FOR RITTAL W400 Date: 23-May-19 M. Michelsson</p>							
<p>Ordering code: 3AXD50000456772 KIT A-4-1234-403-VX</p>							
							



Stage 6: Installation of inverter modules and air guides



1	2	3	4	5	6	7	8
A	B	C	D	E	F	G	H

3AXD5000460755
 ACS880-104-R14-W400-VZ5 LASSM117*

A Initial Approval
 23-May-19 M. Michelsson

STAGE 6: Air guide for module kit installation

See assembly drawing 3AUA0000114397 for details and required additional Rittal and standard parts

Note! Finalize wiring during this stage if Du/Dt filters are not used!

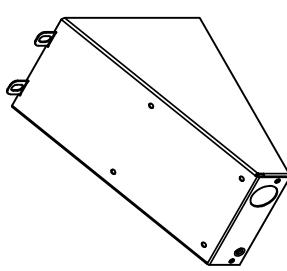

KIT A-468-1-422, Ordering code: (3AUA0000114398) for R1i
 KIT A-468-2-423, Ordering code: (3AUA0000114330) for R2i
 KIT A-468-3-424, Ordering code: (3AUA0000114404) for R3i
 KIT A-468-4-425, Ordering code: (3AUA0000114405) for R4i

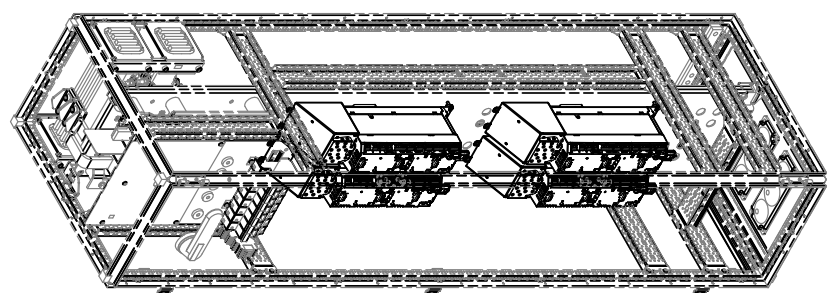

First angle projection. Original drawing made with 3D CAD. Set the correct scale factor when adding dimensions after DWG/DXF conversion.

Based on	Prepared	M. Michelsson	23-May-19	Title	ASSEMBLY DRAWING	Scale	Form	
Customer	Check.	M. Michelsson	23-May-19	ACS880-104-R11-R41-W400	ASSEMBLY DRAWING	1:10	A3	
Cost. No.	Appr.	M. Asikainen	23-May-19	FOR RITTAL VZ5	Rev.ind.	A.0 (DR)	Lang. EN	
DNS Number	Project name	3AXD1000935822		Weight kg	Doc. No.	3AXD50000460755	Sheet 7	
							Total	8

Stage 7: Installation of du/dt filters

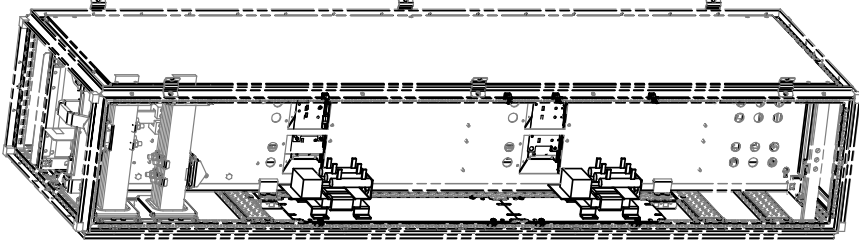
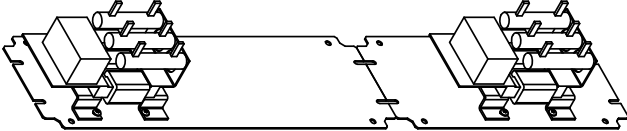
1	2	3	4	5	6	7	8																												
<p>3AXD5000046755 ACS880-04-3124-W400-V1Z5-CAS5-M1171 Initial Approval</p>																																			
<p>23-May-19 M. Michelsson</p>																																			
<p>WE EXCEPT ALL RIGHTS IN THIS DOCUMENT AND IN THE INFORMATION CONTAINED HEREIN. REPRODUCTION, USE OR DISSEMINATION OF THIS DOCUMENT OR ANY PART THEREOF WITHOUT EXPRESS WRITTEN PERMISSION IS STRICTLY FORBIDDEN.</p>																																			
<p>Original drawing made with 3D CAD. Set the correct scale factor when adding dimensions after DWG/DWG conversion.</p>																																			
A	B	C	D	E	F																														
<p>REAR VIEW</p> 																																			
<p>STAGE 7: Du/Dt filter installation (if applicable)</p> <p>See assembly drawing 3AXD50000458721 for details and required additional Rittal and standard parts</p> 																																			
A	B	C	D	E	F																														
<table border="1" style="width: 100%; border-collapse: collapse;"> <tr> <td style="width: 25%;">Based on:</td> <td style="width: 25%;">Prepared:</td> <td style="width: 25%;">Date:</td> <td style="width: 25%;">Title:</td> </tr> <tr> <td>Customer:</td> <td>M. Michelsson</td> <td>23-May-19</td> <td>ASSEMBLY DRAWING</td> </tr> <tr> <td>Project:</td> <td>M. Michelsson</td> <td>23-May-19</td> <td>FOR RITTAL V1Z5</td> </tr> <tr> <td>Plant name:</td> <td>M. Michelsson</td> <td>23-May-19</td> <td></td> </tr> <tr> <td>DMS Number:</td> <td>3AXD10000303882</td> <td>Weight: kg</td> <td></td> </tr> </table>								Based on:	Prepared:	Date:	Title:	Customer:	M. Michelsson	23-May-19	ASSEMBLY DRAWING	Project:	M. Michelsson	23-May-19	FOR RITTAL V1Z5	Plant name:	M. Michelsson	23-May-19		DMS Number:	3AXD10000303882	Weight: kg									
Based on:	Prepared:	Date:	Title:																																
Customer:	M. Michelsson	23-May-19	ASSEMBLY DRAWING																																
Project:	M. Michelsson	23-May-19	FOR RITTAL V1Z5																																
Plant name:	M. Michelsson	23-May-19																																	
DMS Number:	3AXD10000303882	Weight: kg																																	
<table border="1" style="width: 100%; border-collapse: collapse;"> <tr> <td style="width: 25%;">Doc. No.:</td> <td style="width: 25%;">Part No.:</td> <td style="width: 25%;">Doc. No.:</td> <td style="width: 25%;">Part No.:</td> </tr> <tr> <td>3AXD5000046755</td> <td>3AXD5000046755</td> <td>3AXD5000046755</td> <td>3AXD5000046755</td> </tr> <tr> <td>Rev. No.:</td> <td>Rev. No.:</td> <td>Rev. No.:</td> <td>Rev. No.:</td> </tr> <tr> <td>1.0</td> <td>1.0</td> <td>1.0</td> <td>1.0</td> </tr> <tr> <td>Sheet:</td> <td>Sheet:</td> <td>Sheet:</td> <td>Sheet:</td> </tr> <tr> <td>1 of 1</td> <td>1 of 1</td> <td>1 of 1</td> <td>1 of 1</td> </tr> <tr> <td colspan="4" style="text-align: center;">ABB</td> </tr> </table>								Doc. No.:	Part No.:	Doc. No.:	Part No.:	3AXD5000046755	3AXD5000046755	3AXD5000046755	3AXD5000046755	Rev. No.:	Rev. No.:	Rev. No.:	Rev. No.:	1.0	1.0	1.0	1.0	Sheet:	Sheet:	Sheet:	Sheet:	1 of 1	1 of 1	1 of 1	1 of 1	ABB			
Doc. No.:	Part No.:	Doc. No.:	Part No.:																																
3AXD5000046755	3AXD5000046755	3AXD5000046755	3AXD5000046755																																
Rev. No.:	Rev. No.:	Rev. No.:	Rev. No.:																																
1.0	1.0	1.0	1.0																																
Sheet:	Sheet:	Sheet:	Sheet:																																
1 of 1	1 of 1	1 of 1	1 of 1																																
ABB																																			



■ **R1i...R4i modules in a 600 mm wide Rittal VX25 enclosure**

A maximum of eight frame R1i or R2i modules, or four frame R3i or R4i modules can be fitted into a 600 mm wide VX25 enclosure, but the number can be reduced by optional equipment.

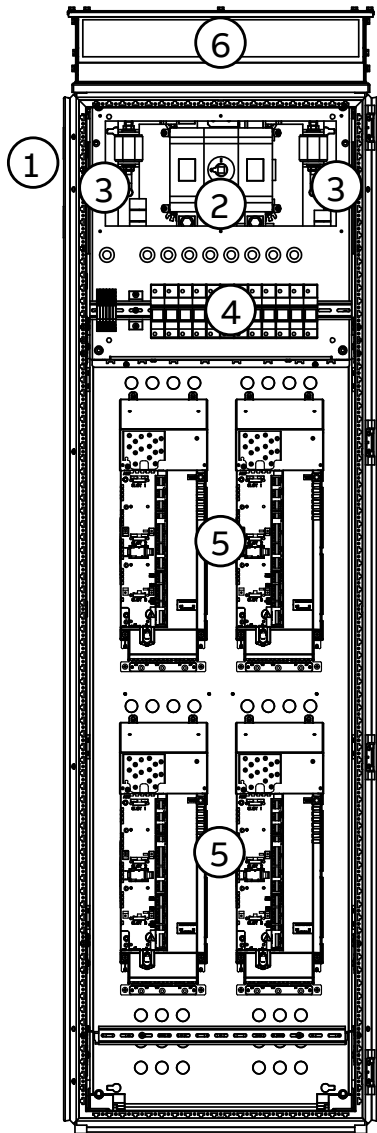

Description

Cubicle including:

1. DC input
2. DC switch/disconnector for all inverter modules
3. Main DC fuses
4. DC fuse disconnector for each inverter
5. Inverter modules
6. Air outlet with exhaust fan



Installation stages

#	Installation stage	Instruction code	Kit code	Kit ordering code
1	Common parts:			
	Baying parts	3AXD50000336340	-	-
	PE busbars	3AXD50000336104	-	-
	Divider panel	3AXD50000336692	-	-
	DC bus support kit	3AXD50000333639	A-468-X-001-VX	3AXD50000333387
2	Bottom plate	-	-	-
3	Mounting plate	3AXD50000468195	-	-
4	DC busbars	3AXD50000460779	A-6-1234-271-VX	3AXD50000475964
5	Mounting plate shrouds	3AXD50000461691	A-6-1234-402-VX	3AXD50000456819
6	Inverter modules and air guides:			
	R1i	3AUA0000114397	A-468-1-422	3AUA0000114398
	R2i	3AUA0000114397	A-468-2-423	3AUA0000114330
	R3i	3AUA0000114397	A-468-3-424	3AUA0000114404
	R4i	3AUA0000114397	A-468-4-425	3AUA0000114405
7	du/dt filters	3AXD50000471713	-	See AC-side components (page 286)



Overview of kits

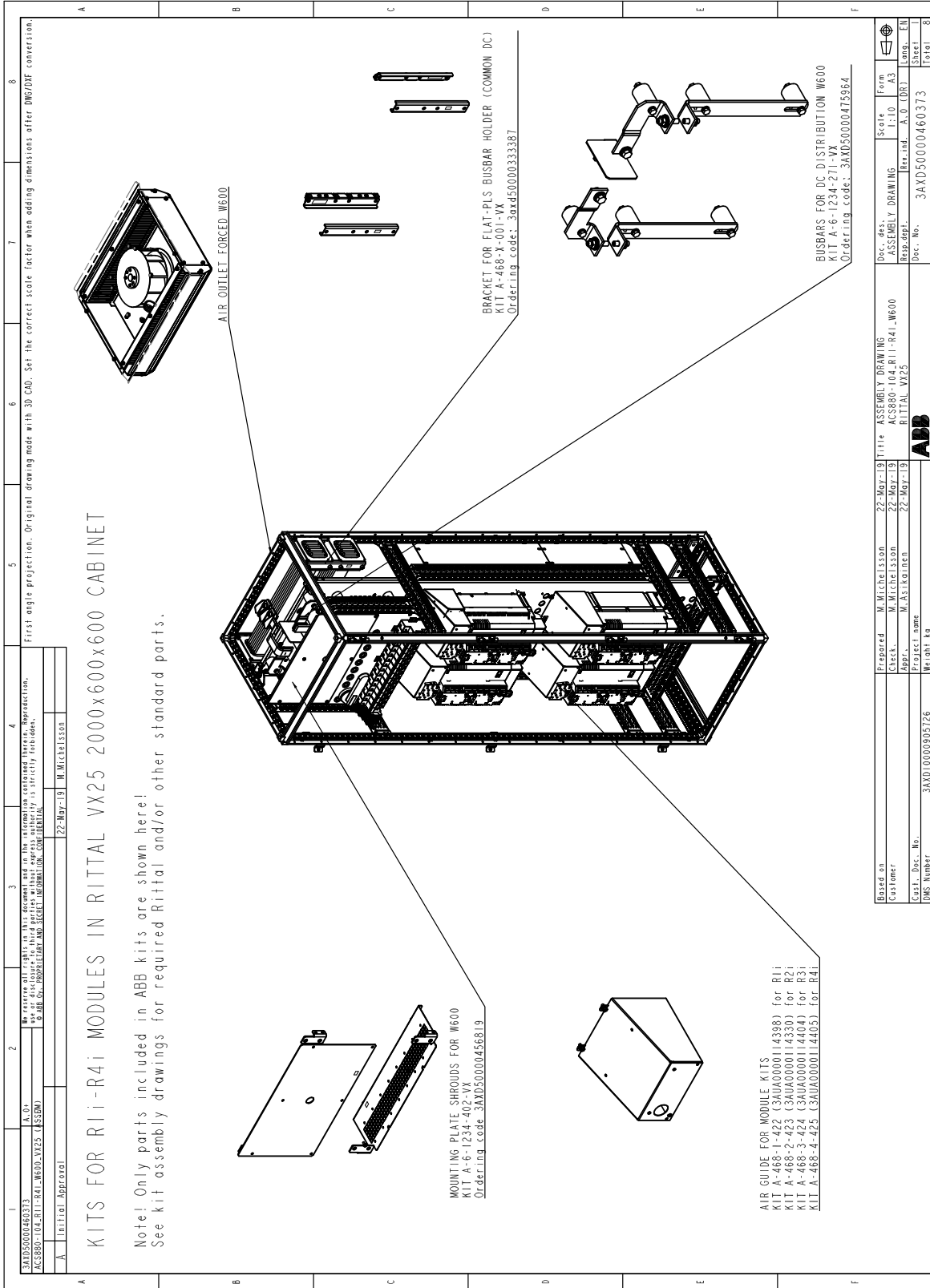

Stage 1: Instalation of common parts

1	2	3	4	5	6	7	8
<p>3AXD50000460373 ASSEMBLY DRAWING 3AXD50000460373</p>							
<p>1.01 No copyright or other rights in this document and in the information contained herein. Reproduction, use or disclosure of this information without express authority is strictly forbidden. CONFIDENTIAL 22-May-19 M. Michelsson</p>							
<p>Initial Approval</p>							
<p>Note! See general cabinet engineering manual for common assembly principles</p> <p>STAGE 1: Common stage installations (Baying parts, PE Bus bar, Divider panel and Common DC)</p> <p>See assembly drawings for details</p>							
<p>Common DC Flat-PLS assembly See drawing_3AXD50000336339</p> <p>DC+ DC-</p> <p>PE bus bar assembly See drawing_3AXD50000336104</p> <p>Divider panel assembly See drawing_3AXD50000336692</p> <p>Baying parts assembly See drawing_3AXD50000336340</p>							
<p>Prepared M. Michelsson 22-May-19 Title ASSEMBLY DRAWING ASSEMBLY DRAWING 3AXD50000460373 INITIAL VZES</p> <p>Checked M. Michelsson 22-May-19 Title ASSEMBLY DRAWING ASSEMBLY DRAWING 3AXD50000460373 INITIAL VZES</p> <p>Drawn M. Michelsson 22-May-19 Title ASSEMBLY DRAWING ASSEMBLY DRAWING 3AXD50000460373 INITIAL VZES</p> <p>Project name 3AXD10000305726 Weight kg</p> <p>Doc. No. 3AXD50000460373 Form No. 300-007 Parts EN Sheets EN Total 8</p>							



Stage 2: Installation of bottom plate

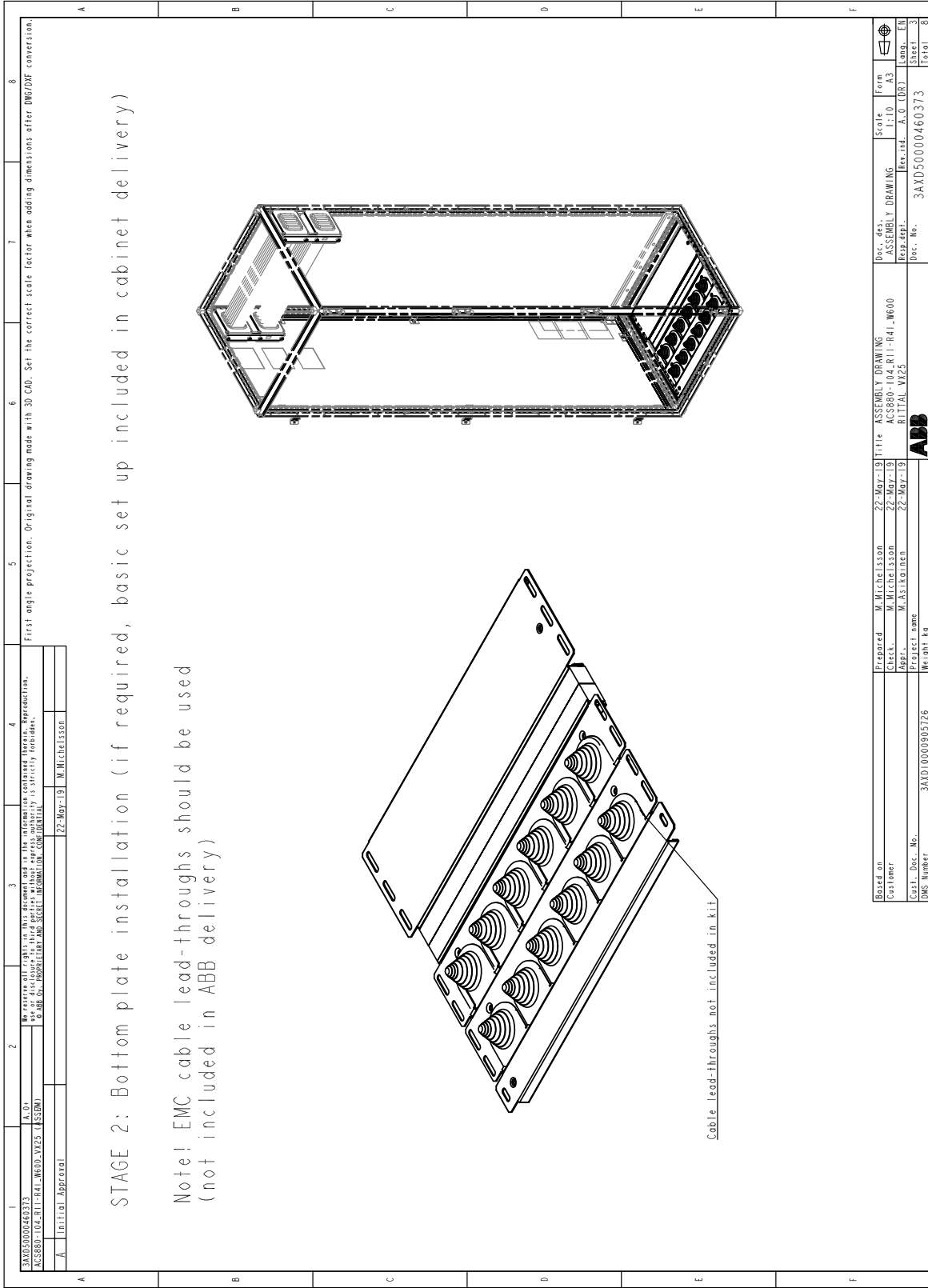

STAGE 2: Bottom plate installation (if required, basic set up included in cabinet delivery)

Note! EMC cable lead-throughs should be used (not included in ABB delivery)

First angle projection. Original drawing made with 3D CAD. Set the correct scale factor when adding dimensions after DWG/DXF conversion.

1	2	3	4	5	6	7	8
3AXD50000460373	A.0*	We reserve all rights to this document and in the information contained herein. Reproduction, distribution, or disclosure of this document is strictly forbidden.					
A	Initial Approval	22-May-19	M. Michelsson				

Based on	Prepared	M. Michelsson	22-May-19	Title	ASSEMBLY DRAWING	Scale	Form	
Customer	Check.	M. Michelsson	22-May-19	AC880-104-R11-R41_W600	ASSEMBLY DRAWING	1:10	A3	
Proj. No.	Appr.	M. Asikainen	22-May-19	PITTA_VX25	Rev. ind.	A.0 (DR)	Lang. EN	
DWG Number	3AXD10000905726	Weight kg						Sheet 3
							3AXD50000460373	Total 3

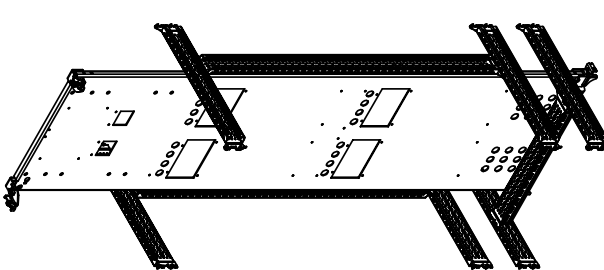
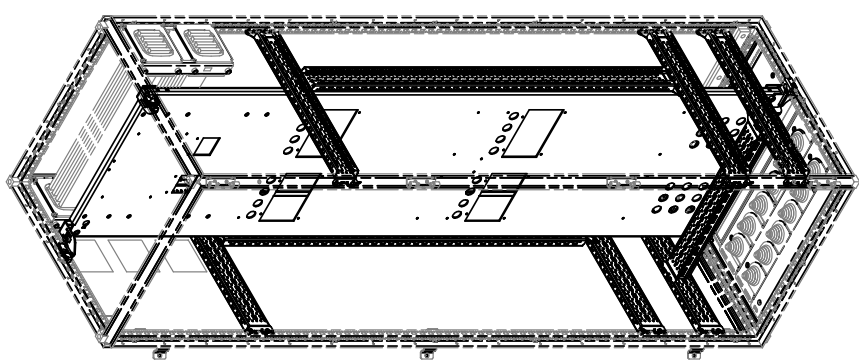

Stage 3: Installation of mounting plate

1	2	3	4	5	6	7	8
<p>3AXD50000460373 ACCESSORY (04-811-841-16600-1) (E41-16600-1) (E41-16600-1) (E41-16600-1) (E41-16600-1) (E41-16600-1) (E41-16600-1) (E41-16600-1)</p>							
<p>1:01 Original drawing made with 3D CAD. Set the correct scale factor when adding dimensions after DWG/DWG conversion.</p>							
<p>First angle projection. Original drawing made with 3D CAD. Set the correct scale factor when adding dimensions after DWG/DWG conversion.</p>							
<p>Prepared by: M. Michelsson Checked by: M. Michelsson Drawn by: M. Michelsson Date: 22-May-19 M. Michelsson</p>							
<p>Initial Approval</p>							
<p>STAGE 3: Mounting plate for W600 installation</p> <p>See assembly drawing 3AXD50000468195 for details and required additional Rittal and standard parts</p>							
							
<p>Doc. No. 3AXD50000460373 Title ASSEMBLY DRAWING Part No. 3AXD50000460373 Rev. 1.0 Date 22-May-19 M. Michelsson</p>							
<p>Weight: kg</p>							



Stage 4: Installation of DC busbars



1	2	3	4	5	6	7	8																																																	
<p>3AXD50000460373 ACS880-104-R11-R41-W600-VX25 (MSSDM) A.01 Initial Approval</p>																																																								
<p>22-May-19 M. Michelsson</p>																																																								
<p>3AXD50000460373 ACS880-104-R11-R41-W600-VX25 (MSSDM) A.01 Initial Approval</p>																																																								
<p>22-May-19 M. Michelsson</p>																																																								
<p>First angle projection. Original drawing made with 3D CAD. Set the correct scale factor when adding dimensions after DWG/DXF conversion.</p>																																																								
<p>STAGE 4: Busbars for DC distribution W600 installation</p> <p>See assembly drawing 3AXD50000460779 for details and required additional Rittal and standard parts</p>																																																								
<p>Ordering code: 3AXD50000475964 KIT A-6-1234-271-VX</p>																																																								
<table border="1" style="width: 100%; border-collapse: collapse;"> <tr> <td>Based on</td> <td>M. Michelsson</td> <td>22-May-19</td> <td>Title</td> <td>ASSEMBLY DRAWING</td> <td>Scale</td> <td>Form</td> </tr> <tr> <td>Customer</td> <td>M. Michelsson</td> <td>22-May-19</td> <td>ACS880-104-R11-R41-W600</td> <td>ASSEMBLY DRAWING</td> <td>1:10</td> <td>A3</td> </tr> <tr> <td>Appr.</td> <td>M. Asikainen</td> <td>22-May-19</td> <td>RITLAL_VX25</td> <td>(Rev. ind.)</td> <td>A.0 (DR)</td> <td>Lang. EN</td> </tr> <tr> <td>Proj. name</td> <td colspan="2">3AXD50000460373</td> <td>Doc. No.</td> <td colspan="3">3AXD50000460373</td> </tr> <tr> <td>DWG Number</td> <td colspan="2">3AXD50000460373</td> <td>Weight kg</td> <td colspan="3"></td> </tr> <tr> <td colspan="3"></td> <td colspan="4" style="text-align: center;">ABB</td> </tr> <tr> <td colspan="3"></td> <td colspan="4" style="text-align: center;">Total 3</td> </tr> </table>								Based on	M. Michelsson	22-May-19	Title	ASSEMBLY DRAWING	Scale	Form	Customer	M. Michelsson	22-May-19	ACS880-104-R11-R41-W600	ASSEMBLY DRAWING	1:10	A3	Appr.	M. Asikainen	22-May-19	RITLAL_VX25	(Rev. ind.)	A.0 (DR)	Lang. EN	Proj. name	3AXD50000460373		Doc. No.	3AXD50000460373			DWG Number	3AXD50000460373		Weight kg							ABB							Total 3			
Based on	M. Michelsson	22-May-19	Title	ASSEMBLY DRAWING	Scale	Form																																																		
Customer	M. Michelsson	22-May-19	ACS880-104-R11-R41-W600	ASSEMBLY DRAWING	1:10	A3																																																		
Appr.	M. Asikainen	22-May-19	RITLAL_VX25	(Rev. ind.)	A.0 (DR)	Lang. EN																																																		
Proj. name	3AXD50000460373		Doc. No.	3AXD50000460373																																																				
DWG Number	3AXD50000460373		Weight kg																																																					
			ABB																																																					
			Total 3																																																					

Stage 5: Installation of mounting plate shrouds

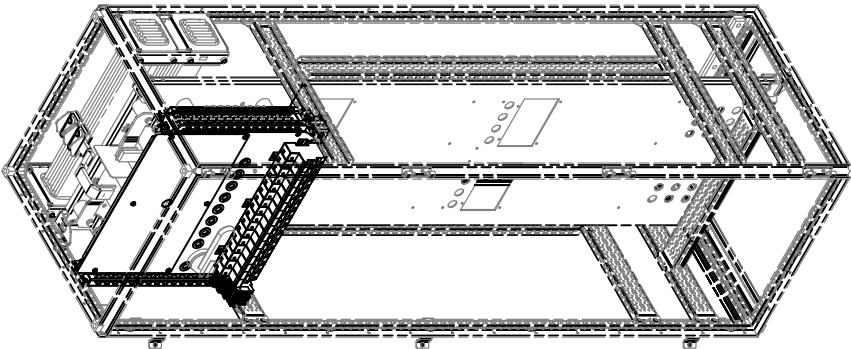
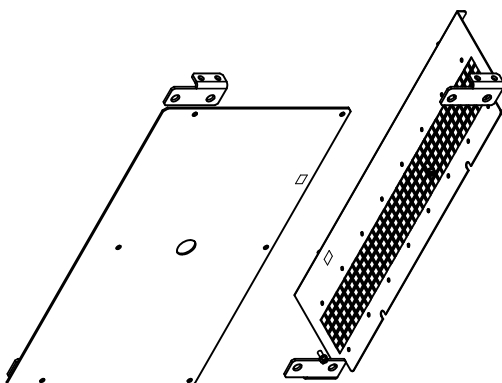
1	2	3	4	5	6	7	8																																			
<p>3AXD50000460373 ASSEMBLY DRAWING 3AXD50000460373</p> <p>1:1 W600-VX25-1 (S5B1)</p> <p>Initial Approval 22-May-19 M. Michelsson</p>																																										
<p>WE EXCEPT ALL RIGHTS IN THIS DOCUMENT AND IN THE INFORMATION CONTAINED HEREIN. REPRODUCTION, STORAGE, TRANSMISSION, OR ANY INFORMATION CONTAINED HEREIN WITHOUT EXPRESS WRITTEN PERMISSION IS STRICTLY FORBIDDEN.</p> <p>ABB CORPORATION AND SERVICE INFORMATION, CONFIDENTIAL</p>																																										
<p>First angle projection. Original drawing made with 3D CAD. Set the correct scale factor when adding dimensions after DWG/DXF conversion.</p>																																										
A	B	C	D	E	F																																					
<p>STAGE 5: Mounting plate shrouds for W600 installation</p> <p>See assembly drawing 3AXD50000461691 for details and required additional Rittal and standard parts</p>						<p>Ordering code: 3AXD50000456819 KIT A-6-1234-402-VX</p>																																				
<table border="1" style="width: 100%; border-collapse: collapse;"> <tr> <td style="width: 15%;">Based on:</td> <td style="width: 15%;">Prepared:</td> <td style="width: 15%;">22-May-19</td> <td style="width: 15%;">Title:</td> <td style="width: 15%;">ASSEMBLY DRAWING</td> <td style="width: 15%;">Scale:</td> <td style="width: 15%;">Form:</td> </tr> <tr> <td>Customer:</td> <td>M. Michelsson</td> <td>22-May-19</td> <td>3AXD50000461691</td> <td>ASSEMBLY DRAWING</td> <td>1:1</td> <td>AS</td> </tr> <tr> <td>Drawn:</td> <td>M. Michelsson</td> <td>22-May-19</td> <td>INITIAL VZ23</td> <td>PREP.:</td> <td>3X0-L007</td> <td>EN</td> </tr> <tr> <td>Checked:</td> <td>M. Michelsson</td> <td>22-May-19</td> <td>ABB</td> <td>Doc. No.:</td> <td>3AXD50000460373</td> <td>Total</td> </tr> <tr> <td>Project name:</td> <td>3AXD10000305726</td> <td></td> <td></td> <td>Weight:</td> <td>kg</td> <td></td> </tr> </table>								Based on:	Prepared:	22-May-19	Title:	ASSEMBLY DRAWING	Scale:	Form:	Customer:	M. Michelsson	22-May-19	3AXD50000461691	ASSEMBLY DRAWING	1:1	AS	Drawn:	M. Michelsson	22-May-19	INITIAL VZ23	PREP.:	3X0-L007	EN	Checked:	M. Michelsson	22-May-19	ABB	Doc. No.:	3AXD50000460373	Total	Project name:	3AXD10000305726			Weight:	kg	
Based on:	Prepared:	22-May-19	Title:	ASSEMBLY DRAWING	Scale:	Form:																																				
Customer:	M. Michelsson	22-May-19	3AXD50000461691	ASSEMBLY DRAWING	1:1	AS																																				
Drawn:	M. Michelsson	22-May-19	INITIAL VZ23	PREP.:	3X0-L007	EN																																				
Checked:	M. Michelsson	22-May-19	ABB	Doc. No.:	3AXD50000460373	Total																																				
Project name:	3AXD10000305726			Weight:	kg																																					



Stage 6: Installation of inverter modules and air guides

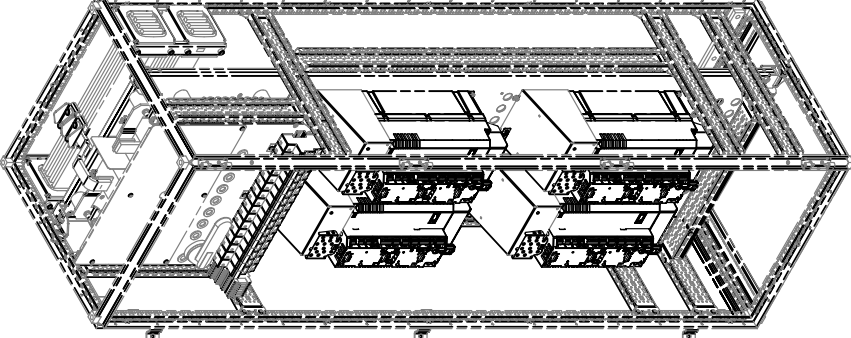
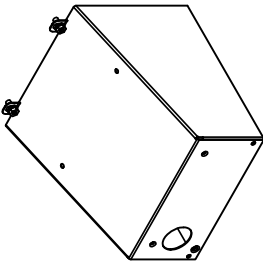

1	2	3	4	5	6	7	8																																			
<p>3AXD50000460373 AC880-104-R1-R4-W600-VX25 (SSDM)</p> <p style="font-size: small;">A.01 We reserve all rights in this document and in the information contained herein. Reproduction, distribution, or use of any part of this document is strictly forbidden. © ABB. All rights reserved. INFORMATION CONTAINED HEREIN IS UNCLASSIFIED.</p> <p>A Initial Approval 22-May-19 M. Michelsson</p>																																										
<p>STAGE 6: Air guide for module kit installation</p> <p>See assembly drawing 3AUA0000114397 for details and required additional Rittal and standard parts</p> <p>Note! Finalize wiring during this stage if Du/Dt filters are not used!</p>																																										
																																										
																																										
<p>KIT A-468-1-422, Ordering code: (3AUA0000114398) for R1 i KIT A-468-2-423, Ordering code: (3AUA0000114330) for R2 i KIT A-468-3-424, Ordering code: (3AUA0000114404) for R3 i KIT A-468-4-425, Ordering code: (3AUA0000114405) for R4 i</p>																																										
<table border="1" style="width: 100%; border-collapse: collapse;"> <tr> <td style="width: 20%;">Based on</td> <td style="width: 20%;">Prepared</td> <td style="width: 20%;">22-May-19</td> <td style="width: 20%;">Title</td> <td style="width: 20%;">ASSEMBLY DRAWING</td> <td style="width: 20%;">Scale</td> <td style="width: 20%;">Form</td> </tr> <tr> <td>Customer</td> <td>M. Michelsson</td> <td>22-May-19</td> <td>AC880-104-R1-R4-W600</td> <td>ASSEMBLY DRAWING</td> <td>1:10</td> <td>A3</td> </tr> <tr> <td>Proj. No.</td> <td>M. Michelsson</td> <td>22-May-19</td> <td>RITTAI_VX25</td> <td>Rev. ind.</td> <td>A.0 (DB)</td> <td>Lang. EN</td> </tr> <tr> <td>DNS Number</td> <td>M. Asikainen</td> <td>22-May-19</td> <td>ABB</td> <td>Doc. No.</td> <td>3AXD50000460373</td> <td>Sheet 7</td> </tr> <tr> <td></td> <td></td> <td></td> <td></td> <td></td> <td></td> <td>Total 8</td> </tr> </table>								Based on	Prepared	22-May-19	Title	ASSEMBLY DRAWING	Scale	Form	Customer	M. Michelsson	22-May-19	AC880-104-R1-R4-W600	ASSEMBLY DRAWING	1:10	A3	Proj. No.	M. Michelsson	22-May-19	RITTAI_VX25	Rev. ind.	A.0 (DB)	Lang. EN	DNS Number	M. Asikainen	22-May-19	ABB	Doc. No.	3AXD50000460373	Sheet 7							Total 8
Based on	Prepared	22-May-19	Title	ASSEMBLY DRAWING	Scale	Form																																				
Customer	M. Michelsson	22-May-19	AC880-104-R1-R4-W600	ASSEMBLY DRAWING	1:10	A3																																				
Proj. No.	M. Michelsson	22-May-19	RITTAI_VX25	Rev. ind.	A.0 (DB)	Lang. EN																																				
DNS Number	M. Asikainen	22-May-19	ABB	Doc. No.	3AXD50000460373	Sheet 7																																				
						Total 8																																				

Stage 7: Installation of du/dt filter

1	2	3	4	5	6	7	8
3AXD5000460373 ACS880-04-311-841-W600-V2ES-1-SSB01 Initial Approval 22-May-19 M. Michelsson							

REAR VIEW

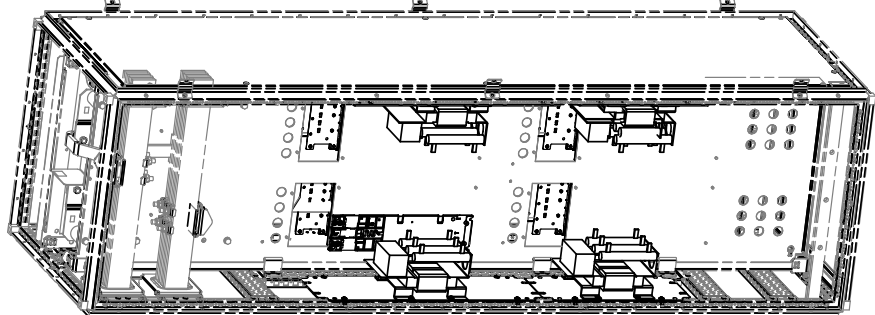

Prepared		M. Michelsson	22-May-19	ASSEMBLY DRAWING	Scale	Form
Checked	M. Michelsson	22-May-19	ASSEMBLY DRAWING	1:1		
Approved	M. Michelsson	22-May-19	ASSEMBLY DRAWING	Revised	Rev. No.	3AXD5000460373
Part name			3AXD5000460373			
Weight			kg			

STAGE 7: Du/Dt filter assembly (if applicable)
 See assembly drawing 3AXD500047173 for details
 and required additional Rittal and standard parts

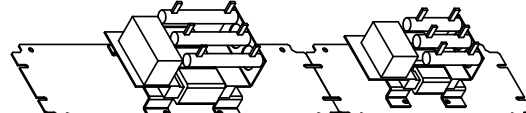
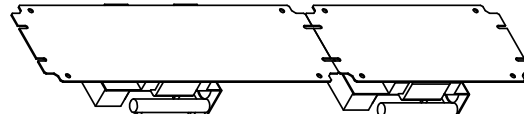



Based on	M. Michelsson	22-May-19	ASSEMBLY DRAWING
Customer	M. Michelsson	22-May-19	ASSEMBLY DRAWING
Part No.	M. Michelsson	22-May-19	ASSEMBLY DRAWING
DMS Number	3AXD10000305726		

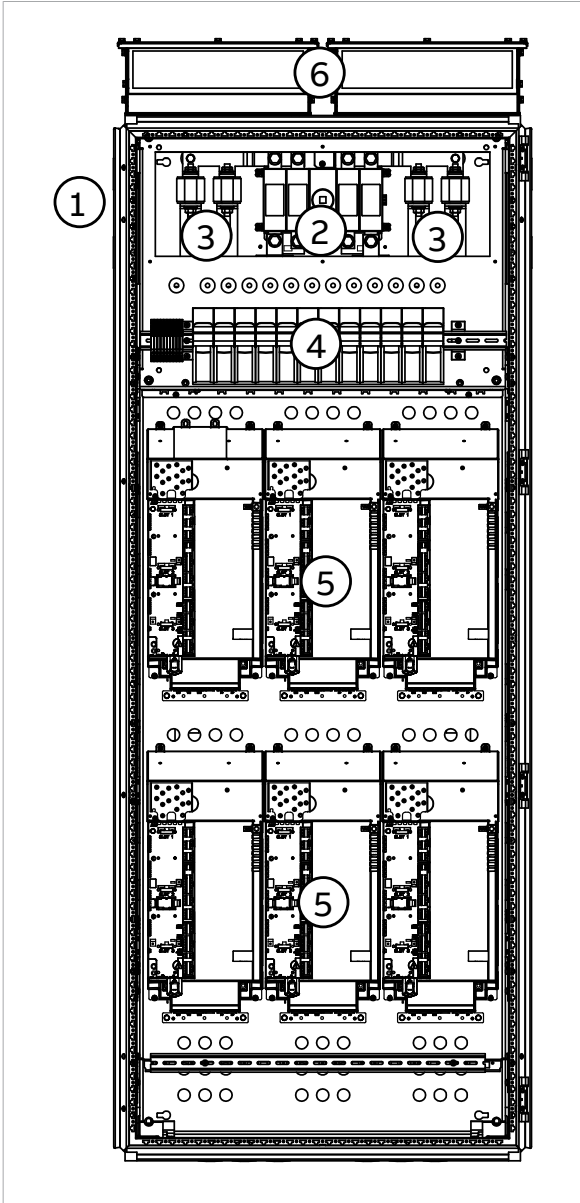

■ **R1i...R4i modules in a 800 mm wide Rittal VX25 enclosure**

A maximum of twelve frame R1i or R2i modules, or six frame R3i or R4i modules can be fitted into a 800 mm wide VX25 enclosure, but the number can be reduced by optional equipment.



Description

Cubicle including:

1. DC input
2. DC switch/disconnector for all inverter modules
3. Main DC fuses
4. DC fuse disconnectors for each inverter module
5. Inverter modules
6. Air outlet with exhaust fan



Installation stages

#	Installation stage	Instruction code	Kit code	Kit ordering code
1	Common parts:			
	Baying parts	3AXD50000336340	-	-
	PE busbars	3AXD50000336104	-	-
	Divider panel	3AXD50000336692	-	-
	DC bus support kit	3AXD50000333639	A-468-X-001-VX	3AXD50000333387
2	Bottom plate	-	-	-
3	Mounting plate	3AXD50000474158	-	-
4	DC busbars	3AXD50000474516	A-8-1234-273-VX	3AXD50000475933
5	Mounting plate shrouds	3AXD50000474882	A-8-1234-404-VX	3AXD50000475926
6	Inverter modules and air guides:			
	R1i	3AUA0000114397	A-468-1-422	3AUA0000114398
	R2i	3AUA0000114397	A-468-2-423	3AUA0000114330
	R3i	3AUA0000114397	A-468-3-424	3AUA0000114404
	R4i	3AUA0000114397	A-468-4-425	3AUA0000114405
7	du/dt filters	3AXD50000475810	-	See AC-side components (page 286)



Overview of kits



1
3AXD50000469147
A.01
A Initial Approval

2
We reserve all rights for this document and on the information contained herein. Reproduction, storage in retrieval systems, or any other use is prohibited without written permission from ABB. © ABB. All rights reserved.

3
23-May-19 M. Michelsson

4
First angle projection. Original drawing made with 3D CAD. Set the correct scale factor when adding dimensions after DWG/DXF conversion.

5

6

7

8

KITS FOR R1i-R4i MODULES IN RITTAL VX25 2000x600x800 CABINET

Note: Only parts included in ABB kits are shown here!
See kit assembly drawings for required Rittal and/or other standard parts.

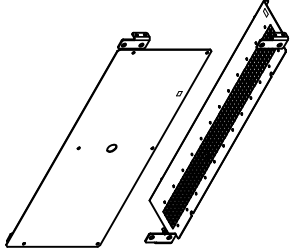

MOUNTING PLATE SHROUDS FOR W800
KIT A-468-4-004-YX (UL KIT A-8-1234-275)
Ordering code: 3AXD50000475926

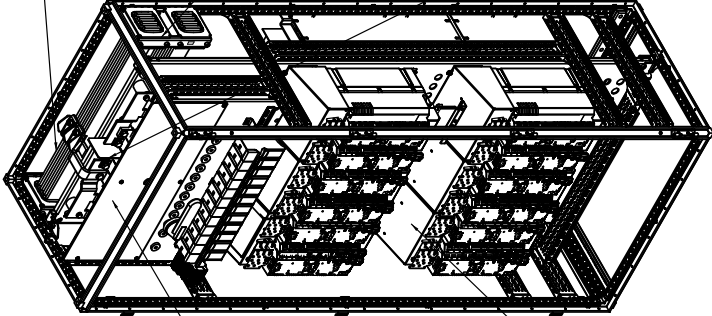

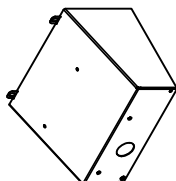

AIR GUIDE FOR MODULE KITS
KIT A-468-1-422 (3AXD50000114398) for R1i
KIT A-468-2-423 (3AXD50000114330) for R2i
KIT A-468-3-424 (3AXD50000114404) for R3i
KIT A-468-4-425 (3AXD50000114405) for R4i

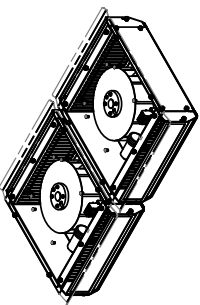

AIR OUTLET FORCED W800

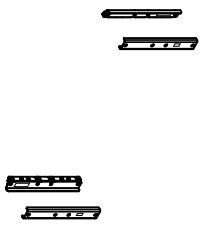

BRACKET FOR FLAT-PLS BUSBAR HOLDER (COMMON DC)
KIT A-468-X-001-YX
Ordering code: 3AXD50000333387

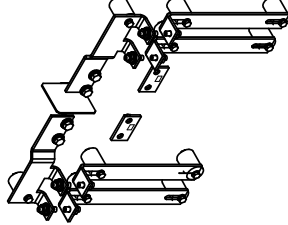

BUSBARS FOR DC DISTRIBUTION W800
KIT A-8-1234-273-YX (UL KIT A-8-1234-275)
Ordering code: 3AXD50000475933 (UL: 3AXD50000003919)

Based on	M. Michelsson	23-May-19	Title	ASSEMBLY DRAWING	Scale	Form
Customer	M. Michelsson	23-May-19	AC880-104-R1i-R4i_W800	ASSEMBLY DRAWING	1:10	A3
Appr.	M. Asikainen	23-May-19	RITTAL VX25	ASSEMBLY DRAWING	A.0 (DB)	EN
Customer No.	3AXD1000912315			Doc. No.	3AXD50000469147	Sheet
DWG Number				Weight kg		Total
						3

Stage 1: Installation of common parts

1	2	3	4	5	6	7	8																																																																		
3AXD50000469147 ACCESSORY (04-311-1641-1800-VZES-1-SSRM) We reserve all rights in this document and in the information contained herein. Reproduction, use or disclosure of this information without express authority is strictly forbidden. © ABB Ltd. PROPRIETARY AND CONFIDENTIAL 23-May-19 M. Michelsson																																																																									
A Initial Approval																																																																									
<p>Note! See general cabinet engineering manual for common assembly principles</p> <p>STAGE 1: Common stage installations (Baying parts, PE Bus bar, Divider panel and Common DC)</p> <p>See assembly drawings for details</p>																																																																									
DC+ DC- Common DC Flat-PLS assembly See drawing 3AXD5000033639																																																																									
Divider panel assembly See drawing 3AXD50000336340																																																																									
Baying parts assembly See drawing 3AXD50000336340																																																																									
PE bus bar assembly See drawing 3AXD50000336104																																																																									
<table border="1" style="font-size: 8px; border-collapse: collapse;"> <tr> <td>Based on:</td> <td>M. Michelsson</td> <td>23-May-19</td> <td>ASSEMBLY DRAWING</td> <td>Scale:</td> <td>Form:</td> </tr> <tr> <td>Prepared:</td> <td>M. Michelsson</td> <td>23-May-19</td> <td>ASSEMBLY DRAWING</td> <td>1:1</td> <td>AS</td> </tr> <tr> <td>Checked:</td> <td>M. Michelsson</td> <td>23-May-19</td> <td>ASSEMBLY DRAWING</td> <td>Err.ind.</td> <td>AS</td> </tr> <tr> <td>Approved:</td> <td>M. Michelsson</td> <td>23-May-19</td> <td>ASSEMBLY DRAWING</td> <td>Err.ind.</td> <td>AS</td> </tr> <tr> <td>Customer:</td> <td>M. Michelsson</td> <td>23-May-19</td> <td>ASSEMBLY DRAWING</td> <td>Err.ind.</td> <td>AS</td> </tr> <tr> <td>Project name:</td> <td>3AXD10000912315</td> <td></td> <td>ASSEMBLY DRAWING</td> <td>Err.ind.</td> <td>AS</td> </tr> <tr> <td>DMS Number:</td> <td>3AXD10000912315</td> <td></td> <td>ASSEMBLY DRAWING</td> <td>Err.ind.</td> <td>AS</td> </tr> <tr> <td colspan="3"></td> <td colspan="3" style="text-align: center;">ABB</td> </tr> <tr> <td colspan="3"></td> <td colspan="3" style="text-align: center;">Doc. No. 3AXD50000469147</td> </tr> <tr> <td colspan="3"></td> <td colspan="3" style="text-align: center;">Part No. 3AXD50000469147</td> </tr> <tr> <td colspan="3"></td> <td colspan="3" style="text-align: center;">Total 8</td> </tr> </table>								Based on:	M. Michelsson	23-May-19	ASSEMBLY DRAWING	Scale:	Form:	Prepared:	M. Michelsson	23-May-19	ASSEMBLY DRAWING	1:1	AS	Checked:	M. Michelsson	23-May-19	ASSEMBLY DRAWING	Err.ind.	AS	Approved:	M. Michelsson	23-May-19	ASSEMBLY DRAWING	Err.ind.	AS	Customer:	M. Michelsson	23-May-19	ASSEMBLY DRAWING	Err.ind.	AS	Project name:	3AXD10000912315		ASSEMBLY DRAWING	Err.ind.	AS	DMS Number:	3AXD10000912315		ASSEMBLY DRAWING	Err.ind.	AS				ABB						Doc. No. 3AXD50000469147						Part No. 3AXD50000469147						Total 8		
Based on:	M. Michelsson	23-May-19	ASSEMBLY DRAWING	Scale:	Form:																																																																				
Prepared:	M. Michelsson	23-May-19	ASSEMBLY DRAWING	1:1	AS																																																																				
Checked:	M. Michelsson	23-May-19	ASSEMBLY DRAWING	Err.ind.	AS																																																																				
Approved:	M. Michelsson	23-May-19	ASSEMBLY DRAWING	Err.ind.	AS																																																																				
Customer:	M. Michelsson	23-May-19	ASSEMBLY DRAWING	Err.ind.	AS																																																																				
Project name:	3AXD10000912315		ASSEMBLY DRAWING	Err.ind.	AS																																																																				
DMS Number:	3AXD10000912315		ASSEMBLY DRAWING	Err.ind.	AS																																																																				
			ABB																																																																						
			Doc. No. 3AXD50000469147																																																																						
			Part No. 3AXD50000469147																																																																						
			Total 8																																																																						



Stage 2: Installation of bottom plate

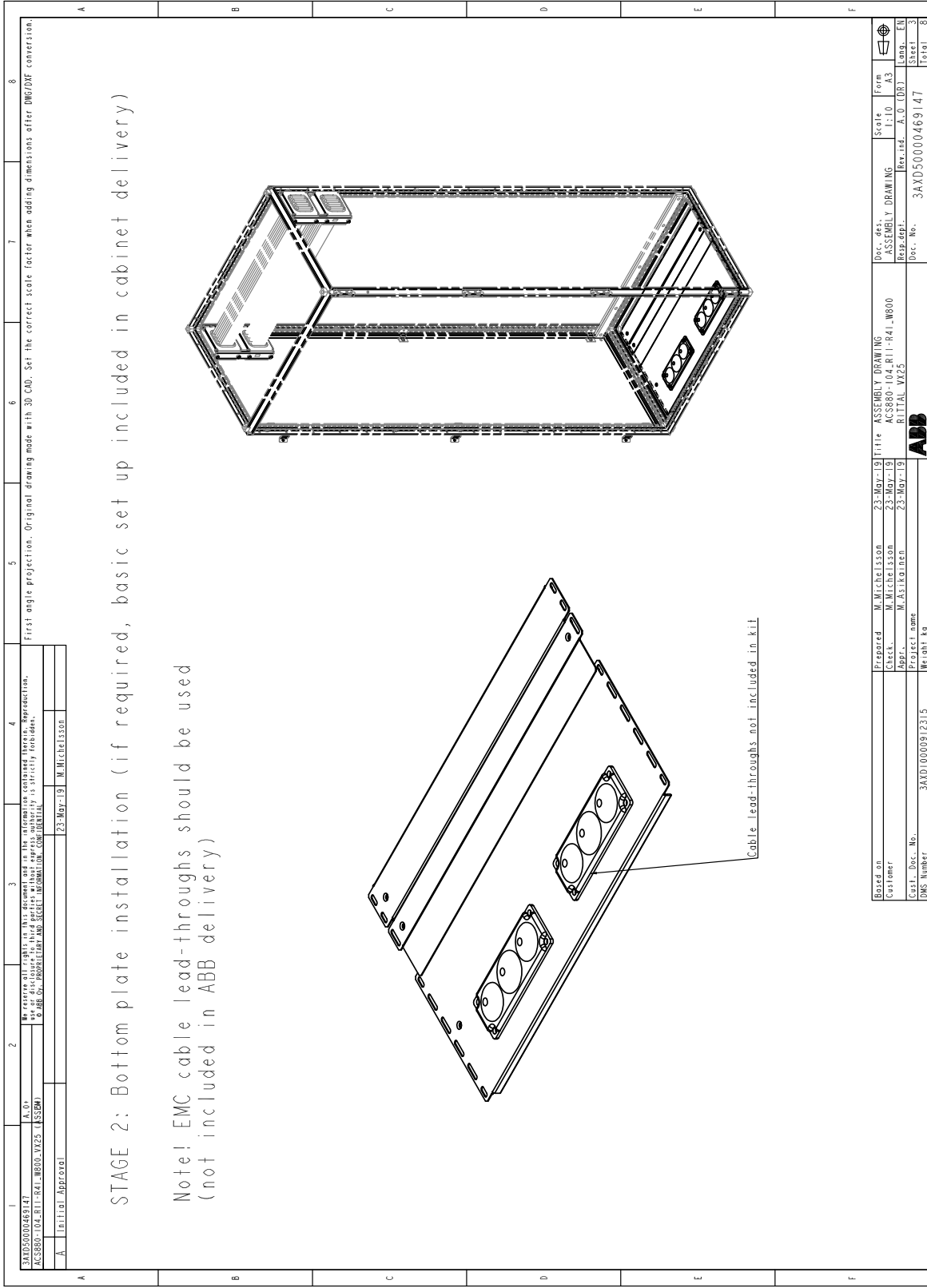

STAGE 2: Bottom plate installation (if required, basic set up included in cabinet delivery)

Note! EMC cable lead-throughs should be used (not included in ABB delivery)

Cable lead-throughs not included in kit

1	2	3	4	5	6	7	8
3AXD50000469147 AC5880-104-R11-R41-W800-VX25 (VSS20M) A.01 No reserved rights in this document and in the information contained herein. Reproduction, distribution, or disclosure of this document or its contents is strictly forbidden. © ABB. All rights reserved. INFORMATION CONTAINED HEREIN IS UNCLASSIFIED.							
Initial Approval		23-May-19		M. Michelsson			
First angle projection. Original drawing made with 3D CAD. Set the correct scale factor when adding dimensions after DWG/DXF conversion.							
A	B	C	D	E	F		

Based on	Prepared	M. Michelsson	23-May-19	Title	ASSEMBLY DRAWING	Scale	Form
Customer	Check.	M. Michelsson	23-May-19	AC5880-104-R11-R41-W800	ASSEMBLY DRAWING	1:10	A3
Customer	Appr.	M. Asikainen	23-May-19	RITTAL VX25	ASSEMBLY DRAWING	A.0 (DB)	Lang. EN
Customer	Project name			ABB	Doc. No.	3AXD50000469147	Sheet 3
Customer	DMS Number	3AXD10000912315	Weight	kg	Total 3		

Stage 3: Installation of mounting plate

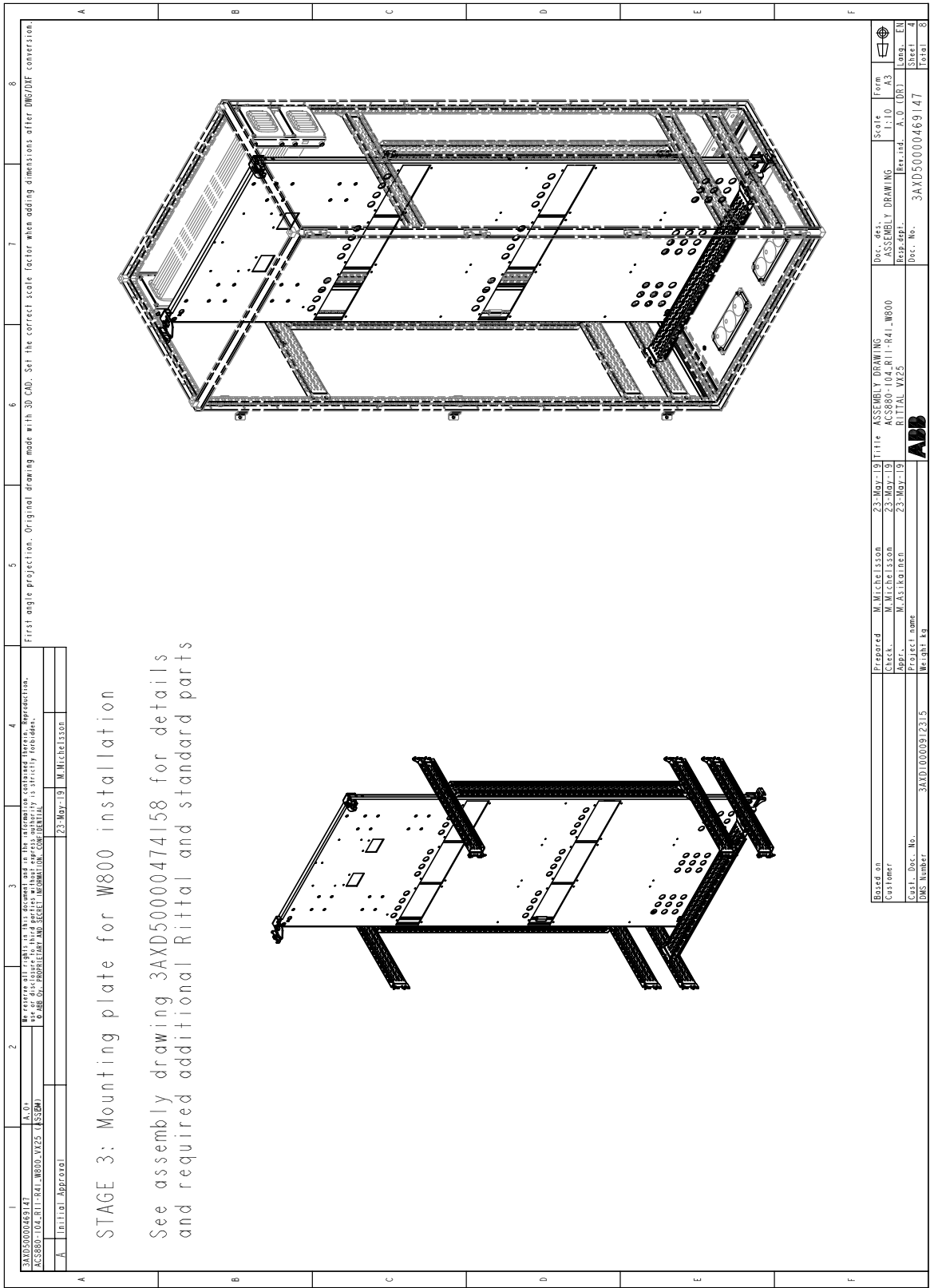

Stage 4: Installation of DC busbars

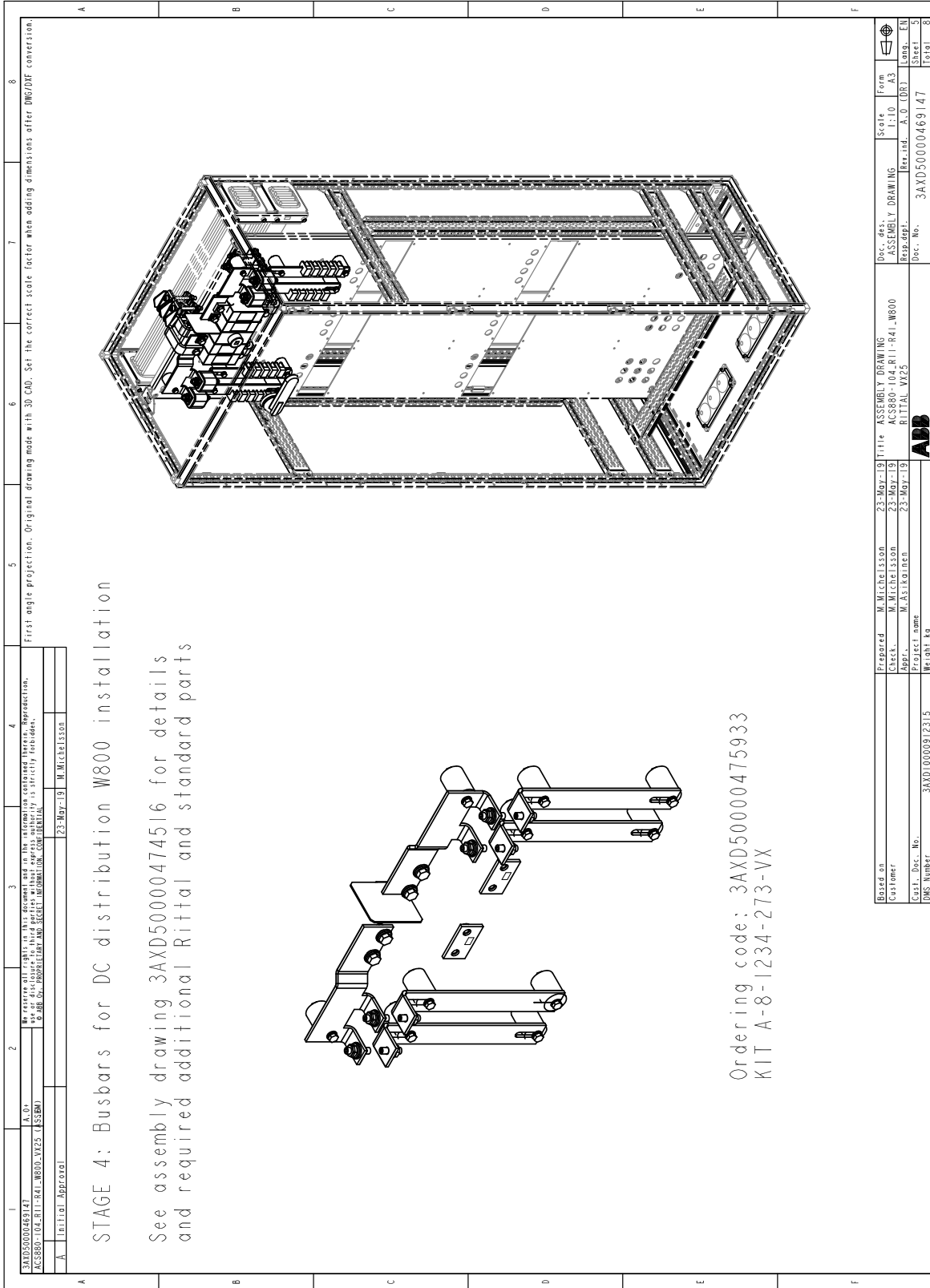

3AXD50000469147
AC8880-104-R11-R41-W800-VX25 (M55EM)

Initial Approval
23-May-19 M. Michelsson

STAGE 4: Busbars for DC distribution W800 installation

See assembly drawing 3AXD50000474516 for details and required additional Rittal and standard parts

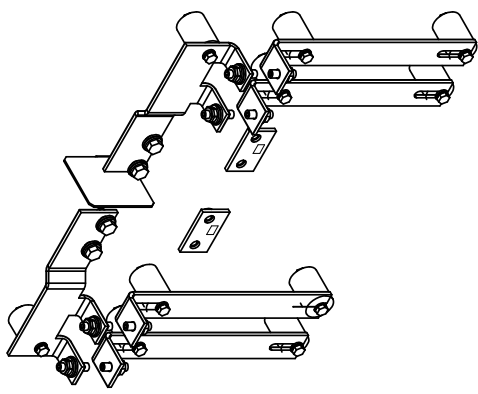

Ordering code: 3AXD50000475933
KIT A-8-1234-273-VX

Based on	Prepared	M. Michelsson	23-May-19	Title	ASSEMBLY DRAWING	Scale	Form
Customer	Check.	M. Michelsson	23-May-19	AC8880-104-R11-R41-W800	ASSEMBLY DRAWING	1:10	A3
Customer	Appr.	M. Asikainen	23-May-19	RITVAL VY25	(Rev. ind.)	A.0 (DR)	Lang. EN
DWG. Number	Project name	3AXD10000912315		Weight kg	Doc. No.	3AXD50000469147	
						Sheet	5
						Total	8



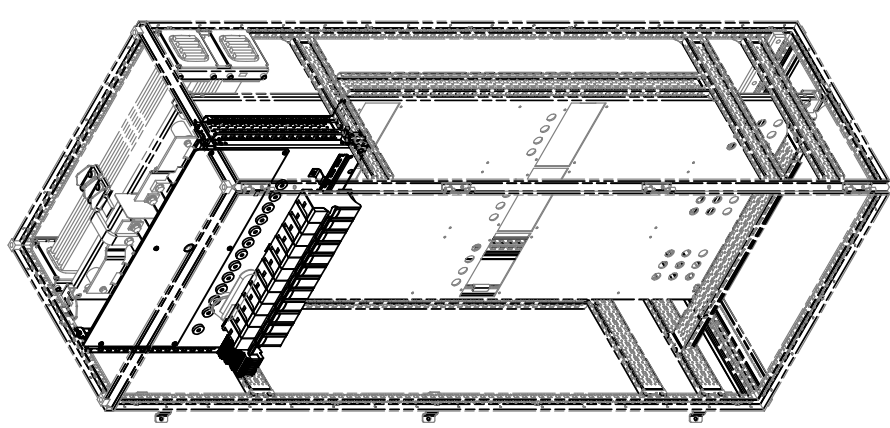
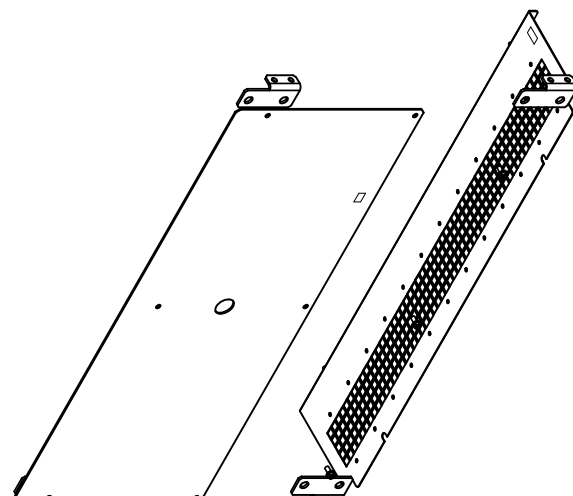

Stage 5: Installation of mounting plate shrouds

1	2	3	4	5	6	7	8
<p>3AXD50000469147 ACS880-10A-311-641-W800-VX25 (S58M) Initial Approval 23-May-19 M. Michelsson</p>							
<p><small>We reserve all rights in this document and in the information contained herein. Reproduction, use or disclosure of this document without express written authority is strictly forbidden. © ABB CORPORATION AND SECTIA INFORMATION, CONFIDENTIAL</small></p>							
<p>First angle projection. Original drawing made with 3D CAD. Set the correct scale factor when adding dimensions after DWG/DXF conversion.</p>							
A	B	C	D	E	F		
<p>STAGE 5: Mounting plate shrouds for W800 installation</p> <p>See assembly drawing 3AXD50000474882 for details and required additional Rittal and standard parts</p>							
<p>Ordering code: 3AXD50000475926 KIT A-8-1234-404-VX</p>							
<p>Based on: M. Michelsson 23-May-19 Checked: M. Michelsson 23-May-19 Drawn: M. Michelsson 23-May-19 Project name: 3AXD10000912315 Weight: kg</p>				<p>Prepared: M. Michelsson 23-May-19 Checked: M. Michelsson 23-May-19 Drawn: M. Michelsson 23-May-19 Project name: 3AXD10000912315 Weight: kg</p>			
<p>Title: ASSEMBLY DRAWING REFERENCE: RITTAL VX25 Doc. No.: 3AXD50000469147</p>				<p>Title: ASSEMBLY DRAWING REFERENCE: RITTAL VX25 Doc. No.: 3AXD50000469147</p>			
<p>Scale: 1:1</p>				<p>Scale: 1:1</p>			
<p>Form: 1</p>				<p>Form: 1</p>			
<p>Sheet: 1 of 1</p>				<p>Sheet: 1 of 1</p>			
<p>Part: 1</p>				<p>Part: 1</p>			
<p>Doc. No.: 3AXD50000469147</p>				<p>Doc. No.: 3AXD50000469147</p>			
<p>Weight: kg</p>				<p>Weight: kg</p>			
<p>Ordering code: 3AXD50000475926 KIT A-8-1234-404-VX</p>				<p>Ordering code: 3AXD50000475926 KIT A-8-1234-404-VX</p>			
<p>ABB</p>							

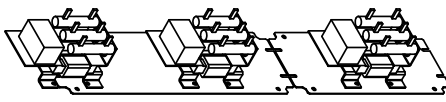
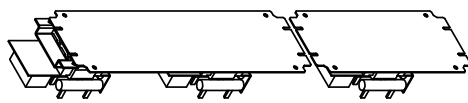
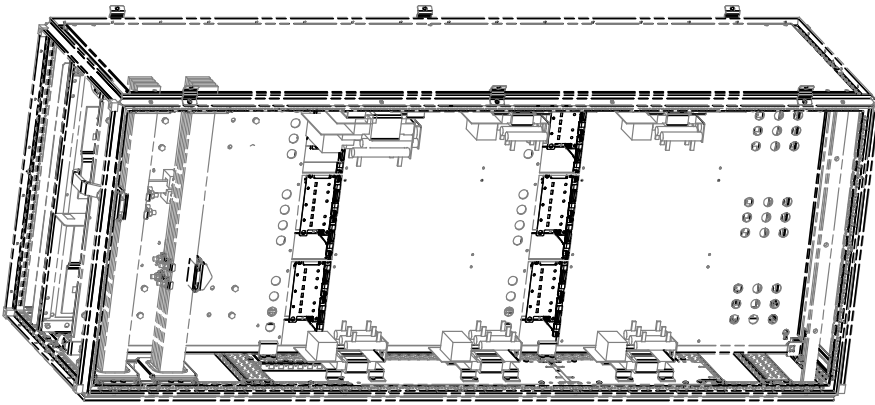

Stage 7: Installation of du/dt filters

1	2	3	4	5	6	7	8
<p>3AXD5000469147 AC380V (U_N=311V, E41, W800, VZ25, F558M) Initial Approval 23-May-19 M. Michelsson</p>							
<p><small>We guarantee all rights in this document and in the information contained herein. Reproduction, use or disclosure of this document without express written authority is strictly forbidden. © ABB. ALL RIGHTS RESERVED. CONFIDENTIAL</small></p>							
<p>First angle projection. Original drawing made with 3D CAD. Set the correct scale factor when adding dimensions after DWG/DWG conversion.</p>							
A	B	C	D	E	F	REAR VIEW	
							
<p>STAGE 7: Du/Dt filter assembly (if applicable) See assembly drawing 3AXD5000475810 for details and required additional Rittal and standard parts</p>							
<p>Based on: Customer: M. Michelsson Project: M. Michelsson Date: M. Michelsson Plant name: 3AXD10000912315 Weight: kg</p>		<p>Prepared by: Checked: M. Michelsson Approved: M. Michelsson Date: 23-May-19 Weight: kg</p>		<p>Title: ASSEMBLY DRAWING Part: 3AXD5000469147 Part: R41-W800 Part: VZ25 Part: F558M</p>		<p>Doc. No.: 3AXD5000469147 Form: 1.0 Rev. No.: 007 Total: 3</p>	
							



■ R5i modules in a 400 mm wide Rittal VX25 enclosure

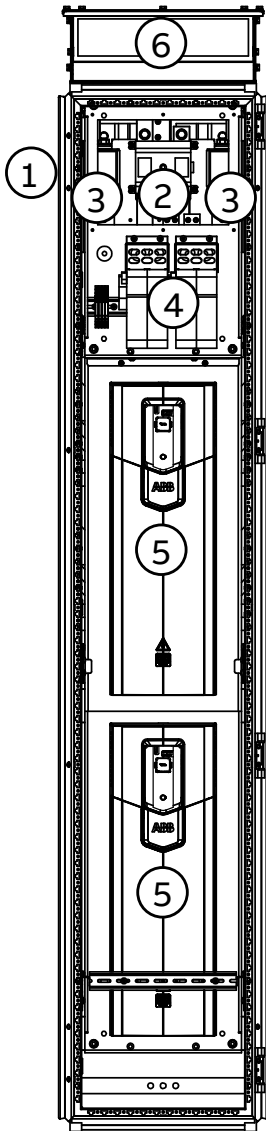

Description

Cubicle including:

1. DC input
2. DC switch/disconnector for all inverter modules
3. Main DC fuses
4. DC fuse disconnectors for each inverter module
5. Inverter modules
6. Air outlet with exhaust fan



Installation stages

#	Installation stage	Instruction code	Kit code	Kit ordering code
1	Common parts:			
	Baying parts	3AXD50000336340	-	-
	PE busbars	3AXD50000336104	-	-
	Divider panel	3AXD50000336692	-	-
	DC bus support kit	3AXD50000333639	A-468-X-001-VX	3AXD50000333387
2	Bottom plate	-	-	-
3	Mounting plate	3AXD50000455188	-	-
4	DC busbars	3AXD50000458110	A-4-5-276-VX	3AXD50000456802
5	Mounting plate shrouds	3AXD50000450060	A-4-1234-403-VX	3AXD50000456772
	Fuse base shroud	3AXD50000458424	A-X-5-356-VX	3AXD50000456796
6	Inverter modules	-	-	-
7	du/dt filters	3AXD50000462094	-	See AC-side components (page 286)



Overview of kits



1
3AXD5000045899
A.O.
A-488-X-001-VX
Initial Approval
21-May-19 M. Michelsson

2
We reserve all rights for this document and in the information contained herein. Reproduction, distribution, or use of this document or the information contained herein is strictly forbidden.
© ABB. ALL RIGHTS RESERVED. INFORMATION CONFIDENTIAL

3
3
4
5
6
7
8

8
7
6
5
4
3
2
1

KITS FOR R5i MODULES IN RITTAL VX25 2000x600x400 CABINET

Note! Only parts included in ABB kits are shown here!
See kit assembly drawings for required Rittal and/or other standard parts.

AIR OUTLET FORCED W400

BRACKET FOR FLAT-PLS BUSBAR HOLDER (COMMON DC)
KIT A-468-X-001-VX
Ordering code: 3AXD50000333387

MOUNTING PLATE SHROUDS FOR W400
KIT A-4-1234-403-VX
Ordering code: 3AXD50000456772

R5i DC BUSBARS W400
KIT A-4-5-276-VX
Ordering code: 3AXD50000456802

R5i FUSEBASE SHROUD
KIT A-X-5-356-VX
Ordering code: 3AXD50000456736

Based on	Prepared	M. Michelsson	21-May-19	Title	ASSEMBLY DRAWING	Scale	Form
Customer	Check.	M. Michelsson	21-May-19	AC880-104 R5i W400	FOR RITTAL VX25	1:25	A3
Customer	Appr.	M. Asikainen	21-May-19				
Proj. No.	3AXD100088280						
Proj. Name							
Weight kg							
ABB							
Doc. No.	3AXD5000045899						
Rev. No.							
Sheet							3
Total							3

Stage 1: Installation of common parts

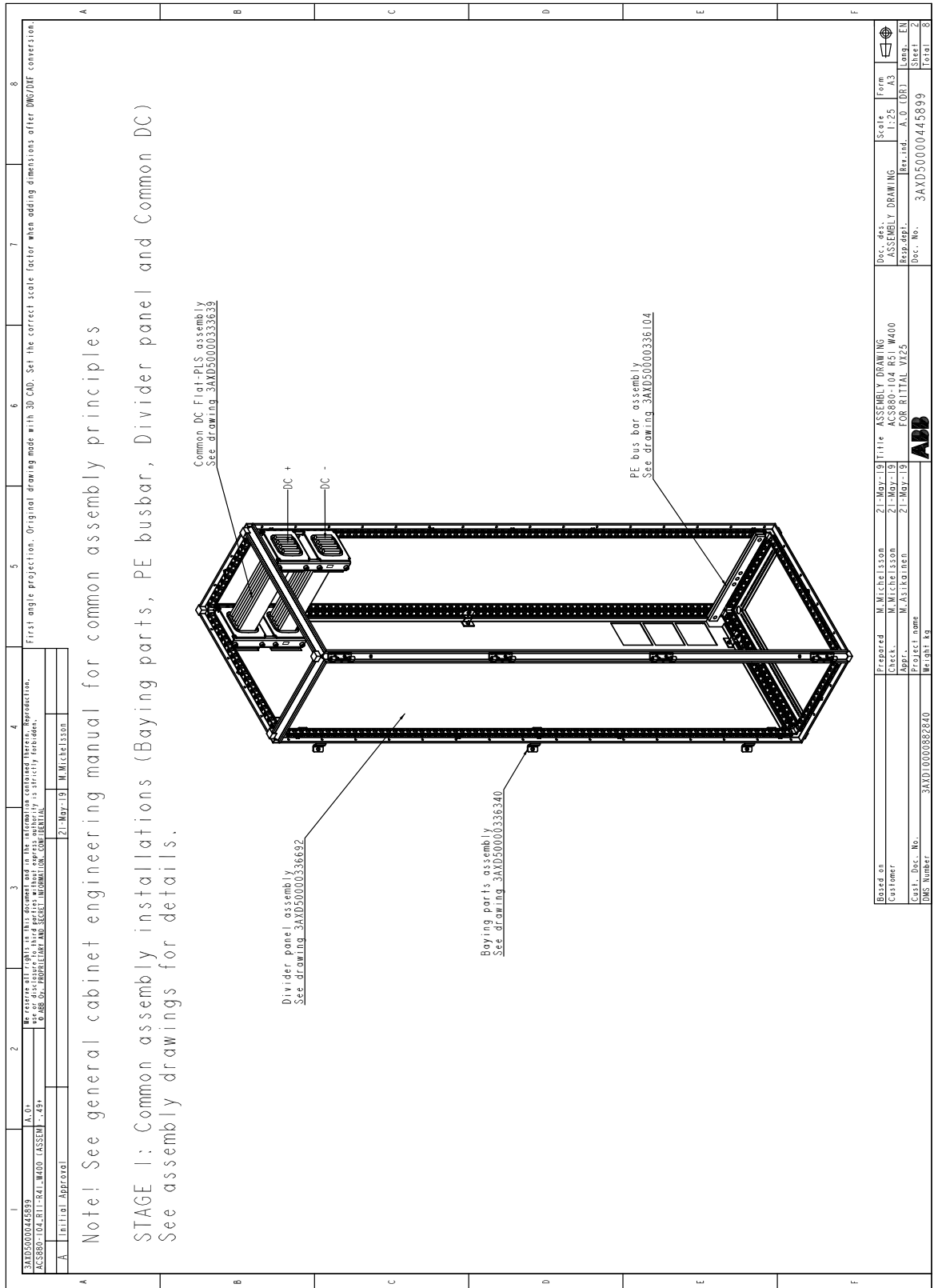

Stage 2: Installation of bottom plate

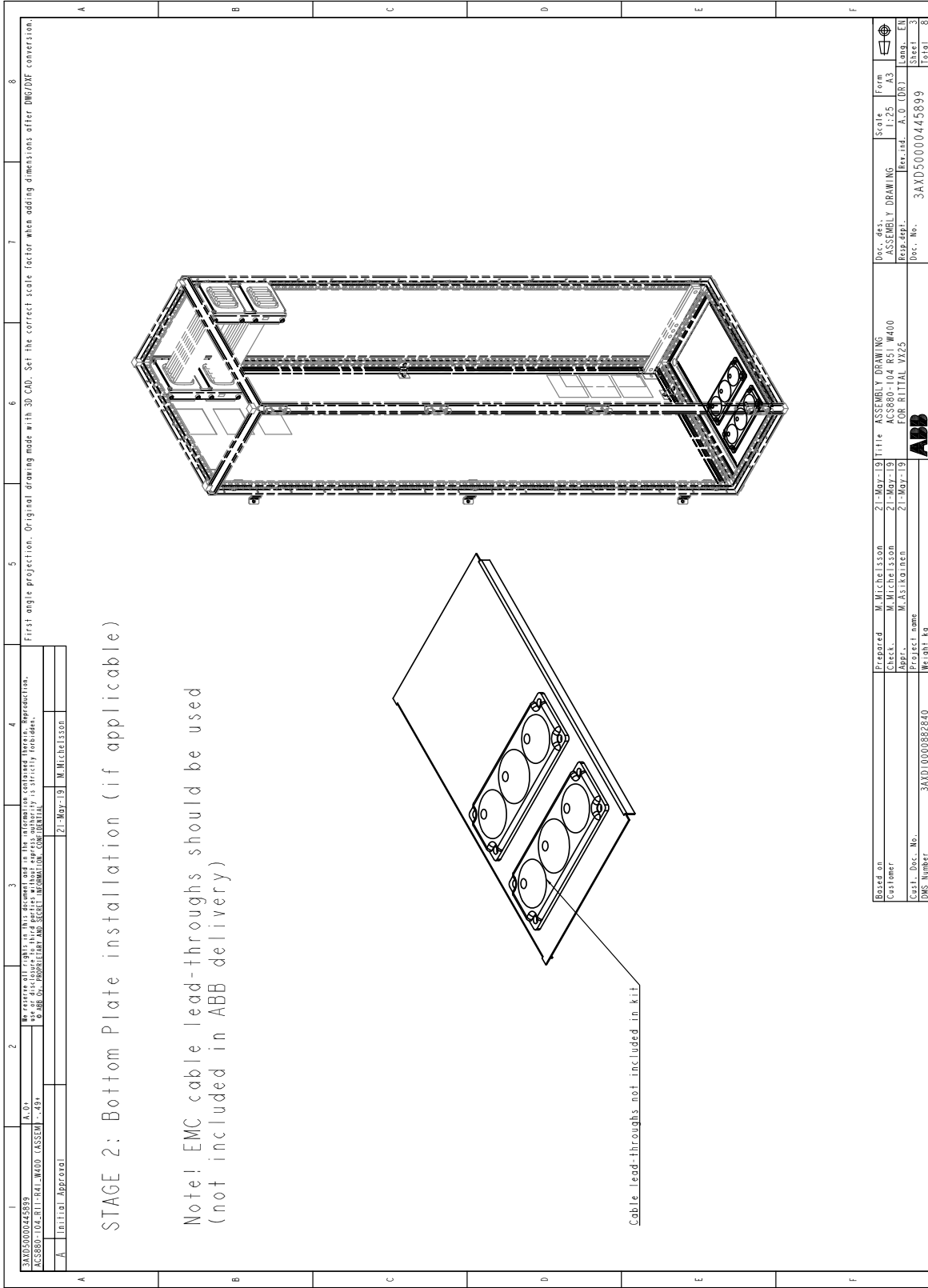

First angle projection. Original drawing made with 3D CAD. Set the correct scale factor when adding dimensions after DWG/DXF conversion.

1	2	3	4	5	6	7	8
3AXD5000045899	A.0*	We reserve all rights for this document and in the information contained herein. Reproduction, distribution, or use of any part of this document is strictly forbidden.		21-May-19	M. Michelsson		
A	Initial Approval						

STAGE 2: Bottom Plate installation (if applicable)

Note! EMC cable lead-throughs should be used (not included in ABB delivery)

Cable lead-throughs not included in kit

Based on	Prepared	M. Michelsson	21-May-19	Title	ASSEMBLY DRAWING	Scale	1:25	Form	A3
Customer	Check.	M. Michelsson	21-May-19	AC880-104 R51 W400	FOR RITTAL V725	Rev.ind.	A.0 (DB)	Lang.	EN
Customer	Appr.	M. Asikainen	21-May-19			Doc. No.	3AXD5000045899	Sheet	3
DWG Number						Weight	kg	Total	3

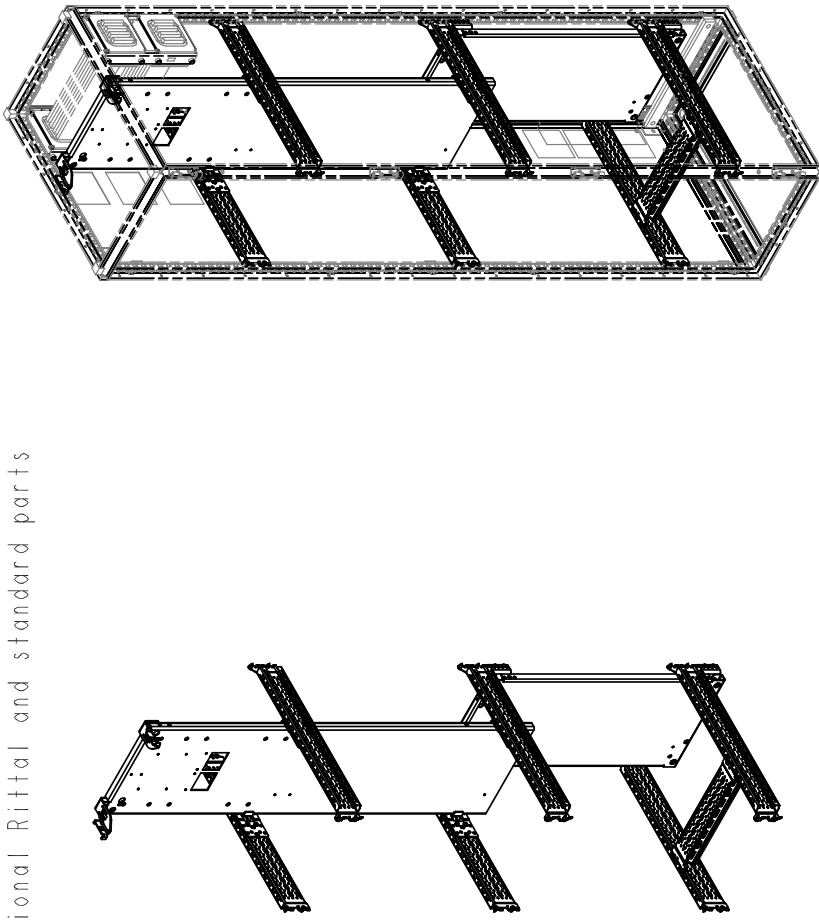

Stage 3: Installation of inverter module mounting plate

1	2	3	4	5	6	7	8
First angle projection. Original drawing made with 3D CAD. Set the correct scale factor when adding dimensions after DWG/DXF conversion.							
<div style="display: flex; justify-content: space-between;"> <div style="width: 45%;"> <p>3AXD500045188 ACCESSORY FOR RITTAL W400 ASSEMBLY DRAWING 1.01 M. MICHELSSON 21-May-19 M. Michelsson</p> <p>STAGE 3: Mounting plates and supports for W400 installation</p> <p>See assembly drawing 3AXD500045188 for details and required additional Rittal and standard parts</p> </div> <div style="width: 50%; text-align: center;">  </div> </div>							
Prepared: M. Michelsson 21-May-19 Checked: M. Michelsson 21-May-19 Drawn: M. Michelsson 21-May-19 Project name: 3AXD10000382840 Weight: kg				Title: ASSEMBLY DRAWING FOR RITTAL W400 FOR RITTAL V23 Doc. No.: 3AXD5000045188 Dec. No.:			
Based on: Customer: Cust. Doc. No.: DNS Number:				Title: Doc. No.: Dec. No.: Weight: kg			
Prepared: M. Michelsson 21-May-19 Checked: M. Michelsson 21-May-19 Drawn: M. Michelsson 21-May-19 Project name: 3AXD10000382840 Weight: kg				Title: ASSEMBLY DRAWING FOR RITTAL W400 FOR RITTAL V23 Doc. No.: 3AXD5000045188 Dec. No.:			
Based on: Customer: Cust. Doc. No.: DNS Number:				Title: Doc. No.: Dec. No.: Weight: kg			



Stage 4: Installation of DC busbars

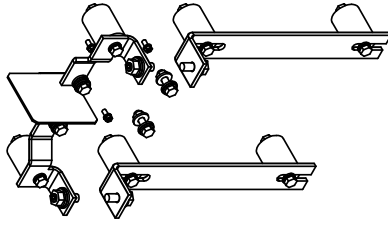
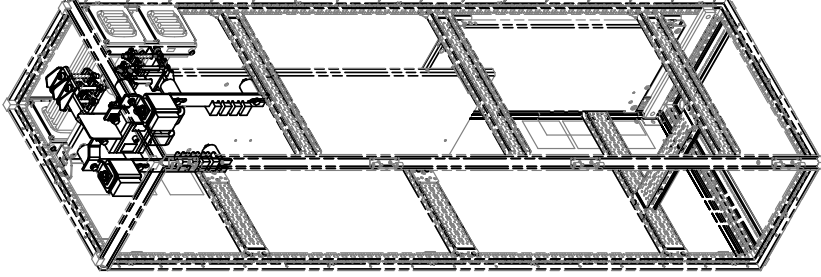

1	2	3	4	5	6	7	8																								
<p>3AXD5000045899 AC880-104-R1-W400 (ASSEM) -49*</p> <p>A Initial Approval</p> <p>21-May-19 M. Michelsson</p>																															
<p>Based on: M. Michelsson 21-May-19 Title: ASSEMBLY DRAWING Customer: AC880-104-R51-W400 Checked: M. Michelsson 21-May-19 Approved: M. Asikainen 21-May-19 Project name: FOR RITTAL VX25 DMS Number: 3AXD100088280 Weight: kg</p>																															
<p>STAGE 4: R5i DC BUSBARS W400 installation</p> <p>See assembly drawing 3AXD50000458110 for details and required additional Rittal and standard parts</p>																															
																															
<p>Ordering code: 3AXD50000456802 KIT A-4-5-276-VX</p>																															
																															
<p>First angle projection. Original drawing made with 3D CAD. Set the correct scale factor when adding dimensions after DWG/DXF conversion.</p>																															
<table border="1" style="width: 100%; border-collapse: collapse;"> <tr> <td>Doc. des.</td> <td>ASSEMBLY DRAWING</td> <td>Scale</td> <td>1:25</td> <td>Form</td> <td>A3</td> </tr> <tr> <td>Resp. des.</td> <td></td> <td>Rev. ind.</td> <td>A.0 (DB)</td> <td>Lang.</td> <td>EN</td> </tr> <tr> <td>Doc. No.</td> <td>3AXD5000045899</td> <td></td> <td></td> <td>Sheet</td> <td>5</td> </tr> <tr> <td></td> <td></td> <td></td> <td></td> <td>Total</td> <td>8</td> </tr> </table>								Doc. des.	ASSEMBLY DRAWING	Scale	1:25	Form	A3	Resp. des.		Rev. ind.	A.0 (DB)	Lang.	EN	Doc. No.	3AXD5000045899			Sheet	5					Total	8
Doc. des.	ASSEMBLY DRAWING	Scale	1:25	Form	A3																										
Resp. des.		Rev. ind.	A.0 (DB)	Lang.	EN																										
Doc. No.	3AXD5000045899			Sheet	5																										
				Total	8																										

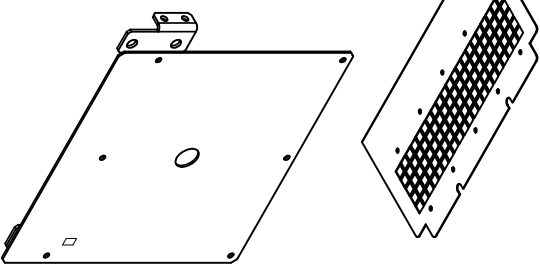
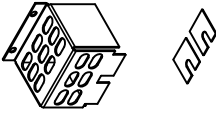
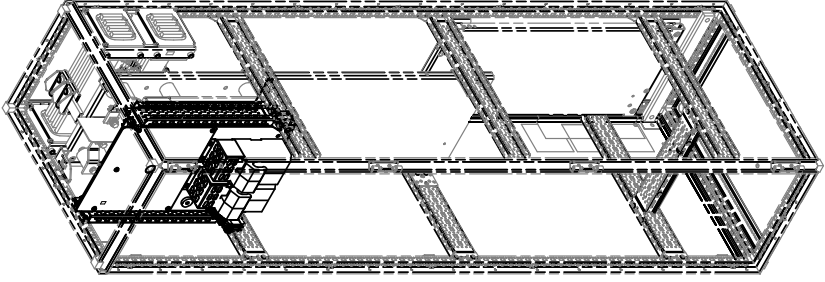

Stage 5: Installation of front mounting plate

1	2	3	4	5	6	7	8
<p>3AXD5000456796 ASSEMBLY DRAWING 1:1 08.05.2019 M. MICHELSSON</p> <p style="font-size: small;">We guarantee all rights in this document and in the information contained herein. Reproduction, use or disclosure of this document without express authority is strictly forbidden. © ABB Ltd. PROPRIETARY AND CONFIDENTIAL INFORMATION. CONFIDENTIAL</p> <p>Prepared M. Michelsson 21-May-19 Checked M. Michelsson 21-May-19 Drawn M. Michelsson 21-May-19 Project name 3AXD10000382840 Weight kg</p>							
<p>STAGE 5: MOUNTING PLATE SHROUDS FOR W400 and R5i FUSEBASE SHROUD installation</p> <p>See assembly drawing 3AXD50000450060 and 3AXD50000458424 for details and required additional Rittal and standard</p>							
							
							
<p>Ordering code: 3AXD50000456772 KIT A-4-1234-403-VX</p> <p>Ordering code: 3AXD50000456796 KIT A-X-5-356-VX 1 kit/module</p>							
<p>Based on: M. Michelsson 21-May-19 Title: ASSEMBLY DRAWING Customer: M. Michelsson 21-May-19 Title: ASSEMBLY DRAWING 3AXD10000382840 M. Michelsson 21-May-19 Title: ASSEMBLY DRAWING FOR RITTAL V22 Project name: 3AXD10000382840 Weight kg: 3AXD5000045899</p> <p style="text-align: right;">ABB</p>							



Stage 6: Installation of inverter modules



1	2	3	4	5	6	7	8																																																																						
3AXD5000045899 ACS880-104-R1-R41-W400 (ASSEM) -49* A.0* We reserve all rights for this document and in the information contained herein. Reproduction, distribution, or use of any part of this document is strictly forbidden. © ABB. ALL INFORMATION CONTAINED HEREIN IS UNCLASSIFIED.																																																																													
A Initial Approval		21-May-19 M. Michelsson																																																																											
<p>STAGE 6: Module installation</p> <p>See ACS880-104 Hardware manual for details</p>																																																																													
First angle projection. Original drawing made with 3D CAD. Set the correct scale factor when adding dimensions after DWG/DXF conversion.																																																																													
<table border="1" style="width: 100%; border-collapse: collapse;"> <tr> <td style="width: 20%;">Based on</td> <td style="width: 20%;">Prepared</td> <td style="width: 20%;">21-May-19</td> <td style="width: 20%;">Title</td> <td style="width: 20%;">ASSEMBLY DRAWING</td> <td style="width: 10%;">Scale</td> <td style="width: 10%;">Form</td> </tr> <tr> <td>Customer</td> <td>Check.</td> <td>M. Michelsson</td> <td>21-May-19</td> <td>ACS880-104-R51-W400</td> <td>1:25</td> <td>A3</td> </tr> <tr> <td>Customer</td> <td>Appr.</td> <td>M. Asikainen</td> <td>21-May-19</td> <td>FOR RITTAL VXR25</td> <td></td> <td></td> </tr> <tr> <td>DWG Number</td> <td colspan="2">3AXD1000882820</td> <td colspan="2">Project name</td> <td colspan="2">Doc. No.</td> </tr> <tr> <td></td> <td colspan="2"></td> <td colspan="2"></td> <td colspan="2">3AXD5000045899</td> </tr> <tr> <td></td> <td colspan="2"></td> <td colspan="2"></td> <td colspan="2">Rev. ind.</td> </tr> <tr> <td></td> <td colspan="2"></td> <td colspan="2"></td> <td colspan="2">A.0 (DR)</td> </tr> <tr> <td></td> <td colspan="2"></td> <td colspan="2"></td> <td colspan="2">Lang. EN</td> </tr> <tr> <td></td> <td colspan="2"></td> <td colspan="2"></td> <td colspan="2">Sheet 7</td> </tr> <tr> <td></td> <td colspan="2"></td> <td colspan="2"></td> <td colspan="2">Total 8</td> </tr> </table>								Based on	Prepared	21-May-19	Title	ASSEMBLY DRAWING	Scale	Form	Customer	Check.	M. Michelsson	21-May-19	ACS880-104-R51-W400	1:25	A3	Customer	Appr.	M. Asikainen	21-May-19	FOR RITTAL VXR25			DWG Number	3AXD1000882820		Project name		Doc. No.							3AXD5000045899							Rev. ind.							A.0 (DR)							Lang. EN							Sheet 7							Total 8	
Based on	Prepared	21-May-19	Title	ASSEMBLY DRAWING	Scale	Form																																																																							
Customer	Check.	M. Michelsson	21-May-19	ACS880-104-R51-W400	1:25	A3																																																																							
Customer	Appr.	M. Asikainen	21-May-19	FOR RITTAL VXR25																																																																									
DWG Number	3AXD1000882820		Project name		Doc. No.																																																																								
					3AXD5000045899																																																																								
					Rev. ind.																																																																								
					A.0 (DR)																																																																								
					Lang. EN																																																																								
					Sheet 7																																																																								
					Total 8																																																																								

Stage 7: Installation of du/dt filters

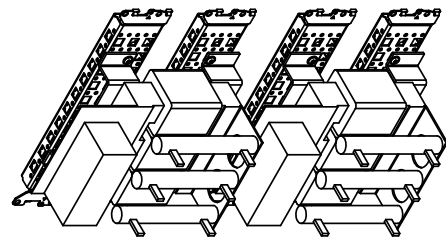
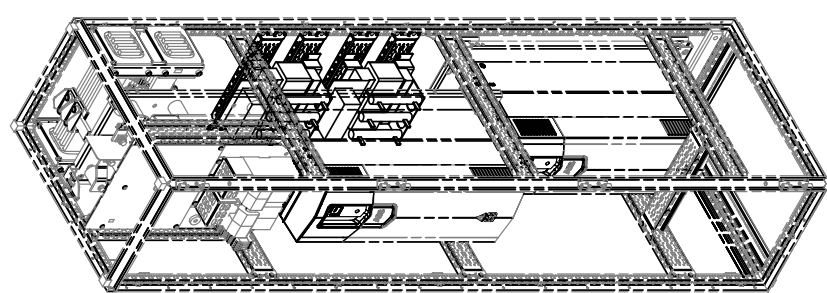
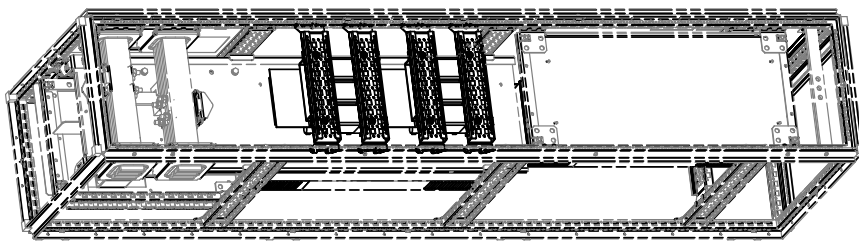
1	2	3	4	5	6	7	8															
First angle projection. Original drawing made with 3D CAD. Set the correct scale factor when adding dimensions after DWG/DWG conversion.																						
<table style="width: 100%; border: none;"> <tr> <td style="width: 20%; border: none;">3AXD5000462094</td> <td style="width: 10%; border: none;">A1.01</td> <td style="width: 50%; border: none;"> We reserve all rights in this document and in the information contained herein. Reproduction, use or disclosure of this document without express authority is strictly forbidden. </td> <td style="width: 15%; border: none;">21-May-19</td> <td style="width: 10%; border: none;">M. Michelsson</td> </tr> <tr> <td colspan="2" style="border: none;">ASSEMBLY DRAWING</td> <td colspan="2" style="border: none;">CONFIDENTIAL</td> <td style="border: none;"></td> </tr> <tr> <td colspan="2" style="border: none;">Initial Approval</td> <td colspan="2" style="border: none;"></td> <td style="border: none;"></td> </tr> </table>								3AXD5000462094	A1.01	We reserve all rights in this document and in the information contained herein. Reproduction, use or disclosure of this document without express authority is strictly forbidden.	21-May-19	M. Michelsson	ASSEMBLY DRAWING		CONFIDENTIAL			Initial Approval				
3AXD5000462094	A1.01	We reserve all rights in this document and in the information contained herein. Reproduction, use or disclosure of this document without express authority is strictly forbidden.	21-May-19	M. Michelsson																		
ASSEMBLY DRAWING		CONFIDENTIAL																				
Initial Approval																						
<p>STAGE 3: Du/Dt filter installation (if applicable)</p> <p>See assembly drawing 3AXD50000462094 for details and required additional Rittal and standard parts</p>																						
<p>FRONT VIEW</p> 				<p>REAR VIEW</p> 																		
<table style="width: 100%; border: none;"> <tr> <td style="width: 30%; border: none;"> Based on: Customer: Cust. Doc. No.: 3AXD10000382840 DMS Number: </td> <td style="width: 20%; border: none;"> Prepared by: M. Michelsson Checked by: M. Michelsson Approved by: M. Michelsson Date: 21-May-19 Weight: kg </td> <td style="width: 10%; border: none;"> Title: ASSEMBLY DRAWING FOR RITTAL V23 </td> <td style="width: 20%; border: none;"> Date: 21-May-19 21-May-19 21-May-19 </td> <td style="width: 10%; border: none;"> Doc. No.: 3AXD50000462094 Rev. No.: 1.00 1.01 1.02 </td> <td style="width: 10%; border: none;"> Form: Y.45 S.30 S.31 S.32 S.33 S.34 S.35 </td> <td style="width: 10%; border: none;"> Total: </td> </tr> </table>								Based on: Customer: Cust. Doc. No.: 3AXD10000382840 DMS Number:	Prepared by: M. Michelsson Checked by: M. Michelsson Approved by: M. Michelsson Date: 21-May-19 Weight: kg	Title: ASSEMBLY DRAWING FOR RITTAL V23	Date: 21-May-19 21-May-19 21-May-19	Doc. No.: 3AXD50000462094 Rev. No.: 1.00 1.01 1.02	Form: Y.45 S.30 S.31 S.32 S.33 S.34 S.35	Total:								
Based on: Customer: Cust. Doc. No.: 3AXD10000382840 DMS Number:	Prepared by: M. Michelsson Checked by: M. Michelsson Approved by: M. Michelsson Date: 21-May-19 Weight: kg	Title: ASSEMBLY DRAWING FOR RITTAL V23	Date: 21-May-19 21-May-19 21-May-19	Doc. No.: 3AXD50000462094 Rev. No.: 1.00 1.01 1.02	Form: Y.45 S.30 S.31 S.32 S.33 S.34 S.35	Total:																



■ R5i modules in a 600 mm wide Rittal VX25 enclosure

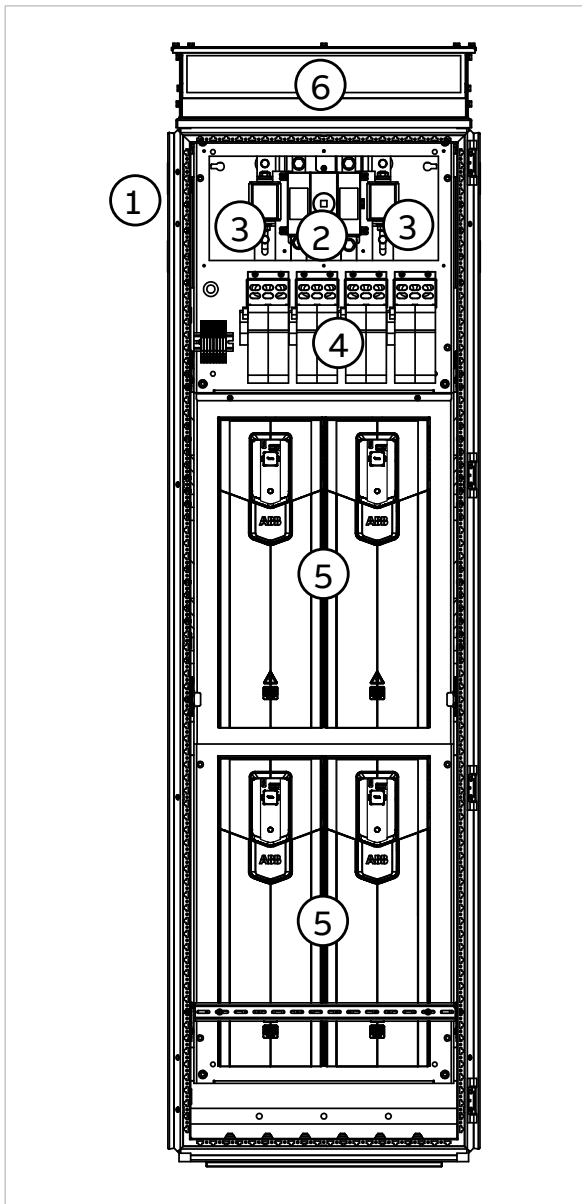

Description

Cubicle including:

1. DC input
2. DC switch/disconnector for all inverter modules
3. Main DC fuses
4. DC fuse disconnectors for each inverter module
5. Inverter modules
6. Air outlet with exhaust fan



Installation stages

#	Installation stage	Instruction code	Kit code	Kit ordering code
1	Common parts:			
	Baying parts	3AXD50000336340	-	-
	PE busbars	3AXD50000336104	-	-
	Divider panel	3AXD50000336692	-	-
	DC bus support kit	3AXD50000333639	A-468-X-001-VX	3AXD50000333387
2	Bottom plate	-	-	-
3	Mounting plate	3AXD50000455188	-	-
4	DC busbars	3AXD50000461332	A-6-5-277-VX	3AXD50000456826
5	Mounting plate shrouds	3AXD50000461691	A-6-1234-402-VX	3AXD50000456819
	Fuse base shroud	3AXD50000458424	A-X-5-356-VX	3AXD50000456796
6	Inverter modules	-	-	-
7	du/dt filters	3AXD50000462094	-	See AC-side components (page 286)



Overview of kits

1
3AXD50000452576
AC8880-104-R11-W600 CASSEM

2

M. Michelsson
21-May-19

3
We reserve all rights for this document and in the information contained herein. Reproduction, distribution, or use of this document is strictly forbidden.
© ABB. ALL INFORMATION CONTAINED HEREIN IS UNCLASSIFIED.

4
M. Michelsson

5

6

7

8

KITS FOR R5i MODULES IN RITTAL VX25 2000x600x600 CABINET

Note: Only parts included in ABB kits are shown here!
See kit assembly drawings for required Rittal and/or other standard parts.

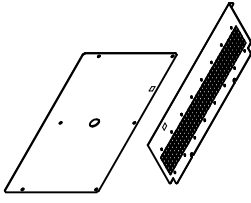

MOUNTING PLATE SHROUDS FOR W600
KIT A-6-1234-402-VX
Ordering code: 3AXD0000455819

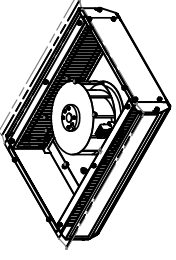

AIR OUTLET FORCED W600

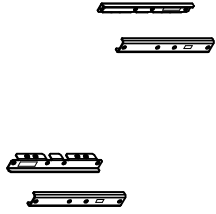

BRACKET FOR FLAT-PLUS BUSBAR HOLDER (COMMON DC)
KIT A-468-X-001-VX
Ordering code: 3AXD5000033387

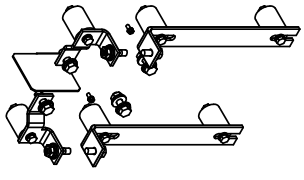

R5i DC BUSBARS W600
KIT A-6-5277-VX
Ordering code: 3AXD50000456826



R5i FUSEBASE SHROUD
1 Kit/module
KIT A-X-5-356-VX
Ordering code: 3AXD50000456796

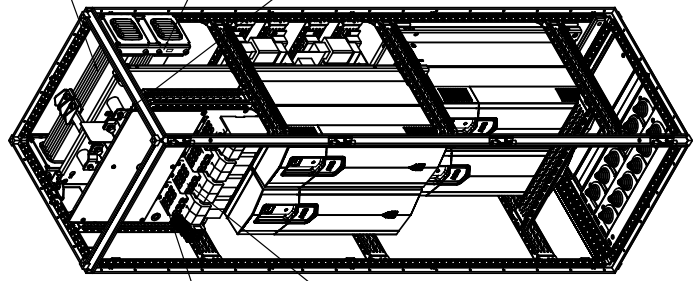

Based on	Prepared	M. Michelsson	21-May-19	Title	ASSEMBLY DRAWING	Scale	Form	
Customer	Check.	M. Michelsson	21-May-19	AC8880-104 R5i W600	ASSEMBLY DRAWING	1:10	A3	
Customer	Appr.	M. Asikainen	21-May-19	FOR RITTAL VX25	FOR RITTAL VX25	Rev. ind.	A.0 (DR)	
Doc. No.	Project name	3AXD1000094501		Weight kg				
DWG Number								
							Sheet	3
							of	3

Stage 1: Installation of common parts

1	2	3	4	5	6	7	8																												
<p>3AXD5000452576 ACCESSORY DRAWING ASSEMBLY Initial Approval 21-May-19 M. Michelsson</p>																																			
<p><small>WE EXCEPT ALL RIGHTS IN THIS DOCUMENT AND IN THE INFORMATION CONTAINED HEREIN. REPRODUCTION, USE OR DISSEMINATION OF THIS DOCUMENT OR ANY PART THEREOF WITHOUT EXPRESS WRITTEN PERMISSION IS STRICTLY FORBIDDEN. © ABB CORPORATION AND SECTIA CORPORATION. CONFIDENTIAL</small></p>																																			
<p>First angle projection. Original drawing made with 3D CAD. Set the correct scale factor when adding dimensions after DWG/DXF conversion.</p>																																			
A	B	C	D	E	F	G	H																												
<p>Note! See general cabinet engineering manual for common assembly principles</p> <p>STAGE 1: Common stage installations (Baying parts, PE Bus bar, Divider panel and Common DC)</p> <p>See assembly drawings for details</p>																																			
<p>Common DC Flat-PLUS assembly See drawing 3AXD5000336339</p> <p>PE bus bar assembly See drawing 3AXD5000336104</p> <p>Divider panel assembly See drawing 3AXD5000336692</p> <p>Baying parts assembly See drawing 3AXD5000336340</p>																																			
<table border="1" style="width: 100%; border-collapse: collapse;"> <tr> <td style="width: 25%;">Based on:</td> <td style="width: 25%;">Prepared by:</td> <td style="width: 25%;">Title:</td> <td style="width: 25%;">Scale:</td> </tr> <tr> <td>M. Michelsson</td> <td>M. Michelsson</td> <td>ASSEMBLY DRAWING</td> <td>1:1</td> </tr> <tr> <td>Customer:</td> <td>Checked by:</td> <td>FOR RITTAL V22</td> <td>Form:</td> </tr> <tr> <td>M. Astikainen</td> <td>M. Michelsson</td> <td>W600</td> <td>AS</td> </tr> <tr> <td>Project name:</td> <td>Approved by:</td> <td>Doc. No.:</td> <td>Rev. No.:</td> </tr> <tr> <td>3AXD1000394501</td> <td>M. Michelsson</td> <td>3AXD5000452576</td> <td>1</td> </tr> <tr> <td>Weight: kg</td> <td colspan="3"></td> </tr> </table>								Based on:	Prepared by:	Title:	Scale:	M. Michelsson	M. Michelsson	ASSEMBLY DRAWING	1:1	Customer:	Checked by:	FOR RITTAL V22	Form:	M. Astikainen	M. Michelsson	W600	AS	Project name:	Approved by:	Doc. No.:	Rev. No.:	3AXD1000394501	M. Michelsson	3AXD5000452576	1	Weight: kg			
Based on:	Prepared by:	Title:	Scale:																																
M. Michelsson	M. Michelsson	ASSEMBLY DRAWING	1:1																																
Customer:	Checked by:	FOR RITTAL V22	Form:																																
M. Astikainen	M. Michelsson	W600	AS																																
Project name:	Approved by:	Doc. No.:	Rev. No.:																																
3AXD1000394501	M. Michelsson	3AXD5000452576	1																																
Weight: kg																																			



Stage 2: Installation of bottom plate

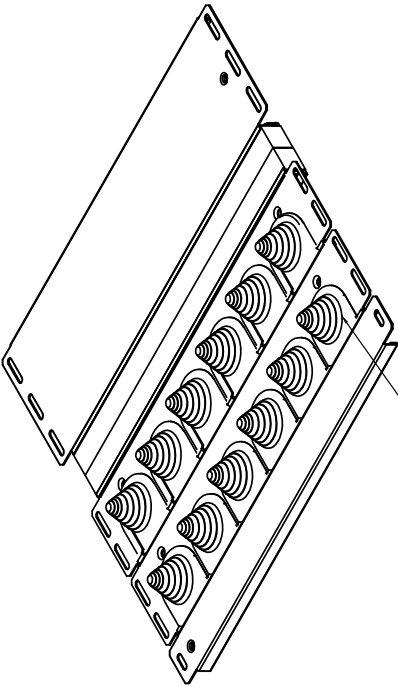
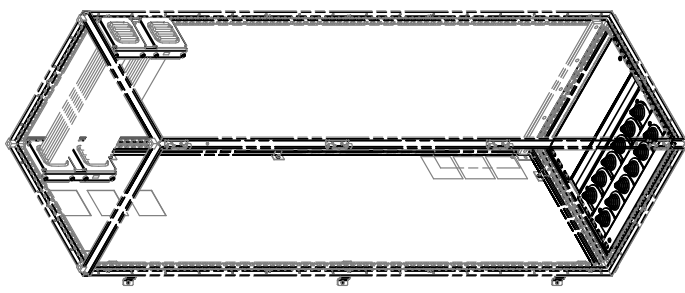

1	2	3	4	5	6	7	8																																																																				
<p>3AXD50000452576 ACS880-104-R1-R41-W600 CASSEM -70*</p> <p>*** We reserve all rights in this document and in the information contained herein. Reproduction, distribution, or disclosure of this document or its contents is strictly prohibited. © ABB. All PROPERTIES AND RIGHTS ARE RESERVED. CONFIDENTIAL</p> <p>Initial Approval 21-May-19 M. Michelsson</p>																																																																											
<p>STAGE 2: Bottom plate installation (if required, basic set up included in cabinet delivery)</p> <p>Note! EMC cable lead-throughs should be used (not included in ABB delivery)</p>																																																																											
																																																																											
<p>Cable lead-throughs not included i.o.k.it</p>																																																																											
<table border="1" style="width: 100%; border-collapse: collapse;"> <tr> <td style="width: 15%;">Based on</td> <td style="width: 15%;">Prepared</td> <td style="width: 15%;">21-May-19</td> <td style="width: 15%;">Title</td> <td style="width: 15%;">ASSEMBLY DRAWING</td> <td style="width: 10%;">Scale</td> <td style="width: 10%;">Form</td> </tr> <tr> <td>Customer</td> <td>Check.</td> <td>M. Michelsson</td> <td>21-May-19</td> <td>ACS880-104-R51-W600</td> <td>1:10</td> <td>A3</td> </tr> <tr> <td>Proj. No.</td> <td>Appr.</td> <td>M. Asikainen</td> <td>21-May-19</td> <td>FOR RITTAL Vx25</td> <td>Rev. no.</td> <td>A.0 (DR)</td> </tr> <tr> <td>DMS Number</td> <td colspan="2">3AXD1000934501</td> <td colspan="2">Weight kg</td> <td colspan="2">3AXD50000452576</td> </tr> <tr> <td colspan="4"></td> <td colspan="2">Doc. No.</td> <td colspan="2">3</td> </tr> <tr> <td colspan="4"></td> <td colspan="2">Rev. No.</td> <td colspan="2">3</td> </tr> <tr> <td colspan="4"></td> <td colspan="2">Lang.</td> <td colspan="2">EN</td> </tr> <tr> <td colspan="4"></td> <td colspan="2">Sheet</td> <td colspan="2">3</td> </tr> <tr> <td colspan="4"></td> <td colspan="2">Total</td> <td colspan="2">3</td> </tr> </table>								Based on	Prepared	21-May-19	Title	ASSEMBLY DRAWING	Scale	Form	Customer	Check.	M. Michelsson	21-May-19	ACS880-104-R51-W600	1:10	A3	Proj. No.	Appr.	M. Asikainen	21-May-19	FOR RITTAL Vx25	Rev. no.	A.0 (DR)	DMS Number	3AXD1000934501		Weight kg		3AXD50000452576						Doc. No.		3						Rev. No.		3						Lang.		EN						Sheet		3						Total		3	
Based on	Prepared	21-May-19	Title	ASSEMBLY DRAWING	Scale	Form																																																																					
Customer	Check.	M. Michelsson	21-May-19	ACS880-104-R51-W600	1:10	A3																																																																					
Proj. No.	Appr.	M. Asikainen	21-May-19	FOR RITTAL Vx25	Rev. no.	A.0 (DR)																																																																					
DMS Number	3AXD1000934501		Weight kg		3AXD50000452576																																																																						
				Doc. No.		3																																																																					
				Rev. No.		3																																																																					
				Lang.		EN																																																																					
				Sheet		3																																																																					
				Total		3																																																																					

Stage 3: Installation of inverter module mounting plate

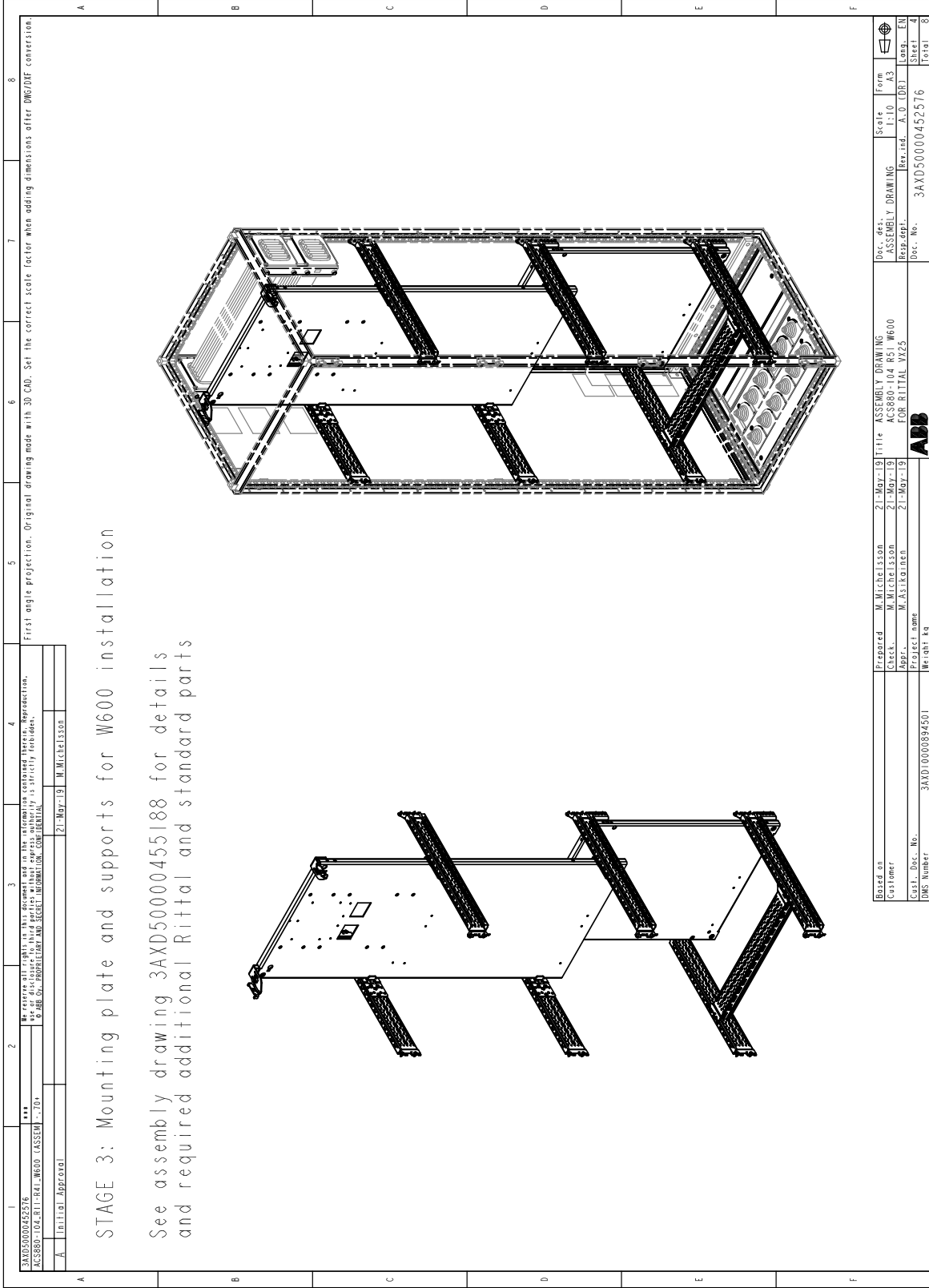

Stage 4: Installation of DC busbars

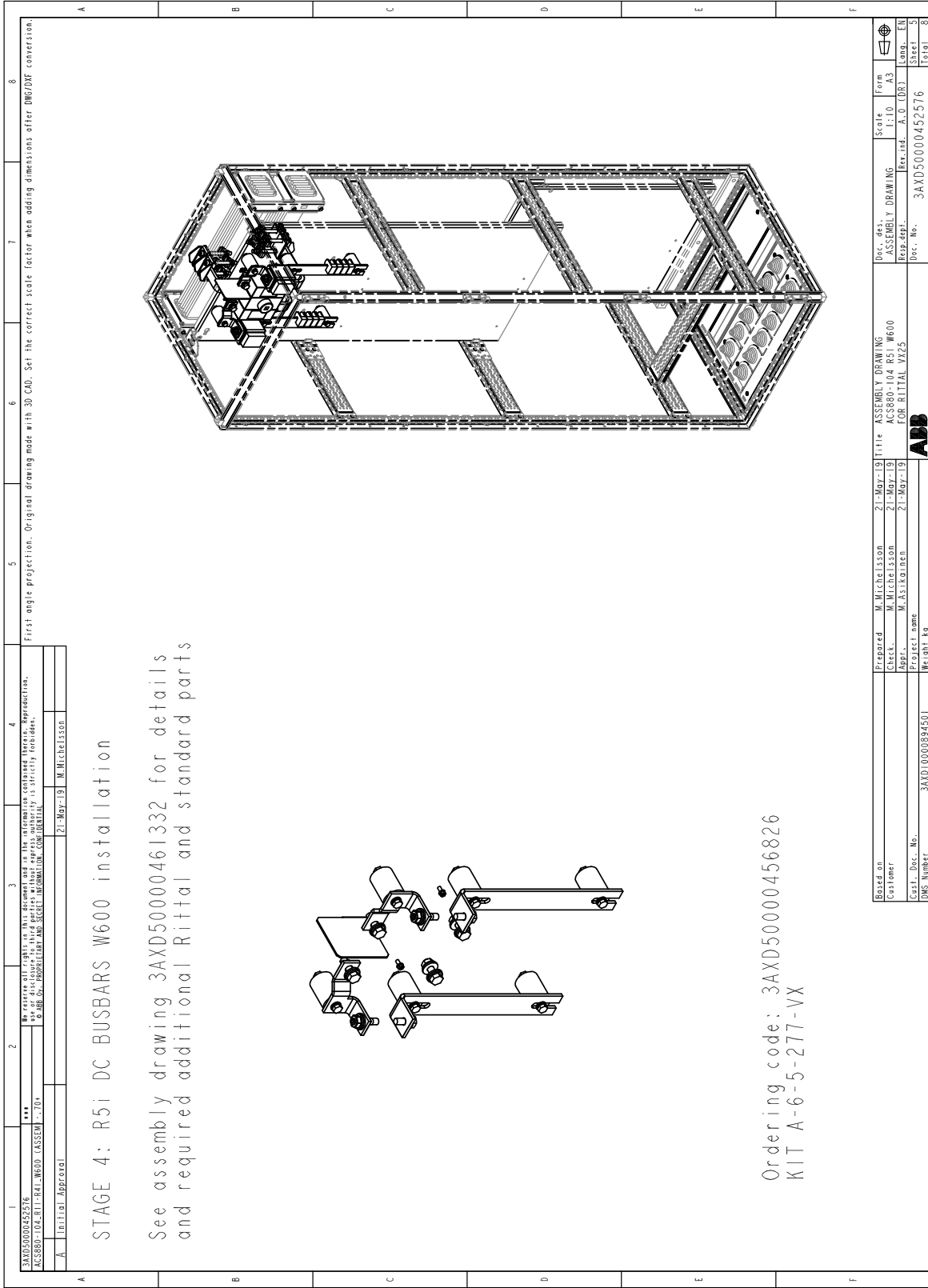

First angle projection. Original drawing made with 3D CAD. Set the correct scale factor when adding dimensions after DWG/DXF conversion.

1	2	3	4	5	6	7	8
3AXD50000452576	***	AC8880-104-R1-R41-W600 (ASSEM) -70*	AC8880-104-R51-W600 (ASSEM) -70*	21-May-19	M. Michelsson		
A	Initial Approval						

STAGE 4: R5i DC BUSBARS W600 installation

See assembly drawing 3AXD50000461332 for details and required additional Rittal and standard parts

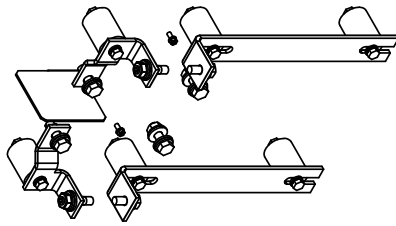



Ordering code: 3AXD50000456826
KIT A-6-5-277-VX

Based on	Prepared	M. Michelsson	21-May-19	Title	ASSEMBLY DRAWING	Scale	1:10	Form	A3
Customer	Check.	M. Michelsson	21-May-19	AC8880-104-R51-W600	FOR RITTAL VX25	Rev. ind.	A.0 (DR)	Lang.	EN
Customer, Doc. No.	Appr.	M. Asikainen	21-May-19			Doc. No.	3AXD50000452576	Sheet	5
DWG Number	Project name					Weight kg		Total	3

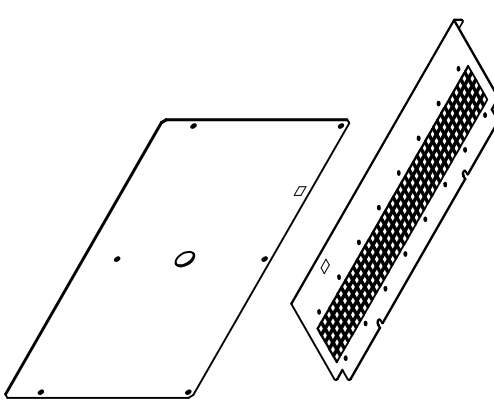

Stage 5: Installation of front mounting plate

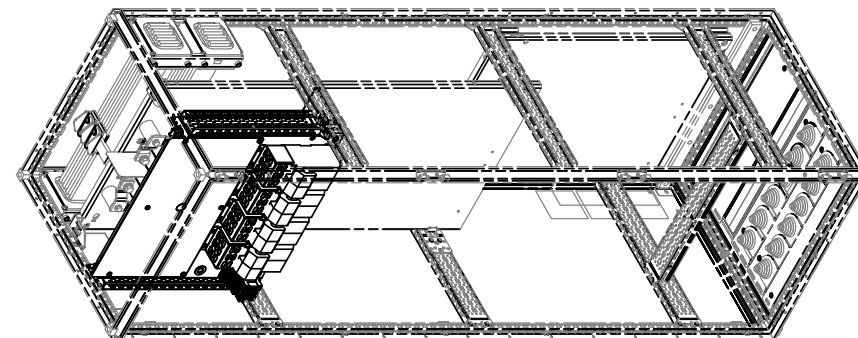
1	2	3	4	5	6	7	8		
3AXD50000456796 ASSEMBLY DRAWING W600 Initial Approval Prepared by: M. Michelsson Date: 21-May-19				3AXD50000458424 ASSEMBLY DRAWING W600 Initial Approval Prepared by: M. Michelsson Date: 21-May-19				3AXD50000452576 ASSEMBLY DRAWING W600 Initial Approval Prepared by: M. Michelsson Date: 21-May-19	
WE TAKE NO RESPONSIBILITY FOR THE INFORMATION CONTAINED HEREIN. REPRODUCTION, STORAGE, DISTRIBUTION, OR USE OF THIS INFORMATION WITHOUT EXPRESS WRITTEN PERMISSION IS STRICTLY FORBIDDEN. Original drawing made with 3D CAD. Set the correct scale factor when adding dimensions after DWG/DWG conversion.									
<p>STAGE 5: Mounting plate shrouds for W600 installation</p> <p>See assembly drawing 3AXD50000461691 and 3AXD50000458424 for details and required additional Ritral and standard parts</p>  									
<p>Ordering code: 3AXD50000456819 Ordering code: 3AXD50000456796 KIT A-6-1234-402-VX KIT A-X-5-356-VX l kit/module l kit/module</p>									
									



Stage 6: Installation of inverter modules



1	2	3	4	5	6	7	8																																													
<p>3AXD50000452576 ACS880-104-R11-R41-W600 (ASSEM) -70*</p> <p>*** We reserve all rights in this document and in the information contained herein. Reproduction, distribution, or use of any part of this document is strictly forbidden. © ABB. ALL RIGHTS RESERVED. INFORMATION CONTAINED HEREIN IS UNCLASSIFIED.</p> <p>Initial Approval 21-May-19 M. Michelsson</p>																																																				
<p>First angle projection. Original drawing made with 3D CAD. Set the correct scale factor when adding dimensions after DWG/DXF conversion.</p>																																																				
A	B	C	D	E	F																																															
<p>STAGE 6: Module installation</p> <p>See ACS880-104 Hardware manual for details</p>																																																				
<table border="1" style="width: 100%; border-collapse: collapse;"> <tr> <td style="width: 20%;">Based on</td> <td>M. Michelsson</td> <td style="width: 10%;">21-May-19</td> <td style="width: 10%;">Title</td> <td>ASSEMBLY DRAWING</td> <td style="width: 10%;">Scale</td> <td>1:10</td> <td style="width: 10%;">Form</td> <td>A3</td> </tr> <tr> <td>Customer</td> <td>M. Michelsson</td> <td>21-May-19</td> <td>ACS880-104 R51 W600</td> <td>FOR RITTAL VX25</td> <td>Rev. no.</td> <td>A.0 (DR)</td> <td>Lang.</td> <td>EN</td> </tr> <tr> <td>Customer, Doc. No.</td> <td>3AXD50000452576</td> <td>21-May-19</td> <td>Project name</td> <td></td> <td>Doc. No.</td> <td>3AXD50000452576</td> <td>Sheet</td> <td>7</td> </tr> <tr> <td>DNS Number</td> <td>3AXD10000944501</td> <td></td> <td>Weight kg</td> <td></td> <td colspan="4" style="text-align: center;">ABB</td> </tr> <tr> <td colspan="4"></td> <td colspan="4" style="text-align: right;">Total</td> <td>8</td> </tr> </table>								Based on	M. Michelsson	21-May-19	Title	ASSEMBLY DRAWING	Scale	1:10	Form	A3	Customer	M. Michelsson	21-May-19	ACS880-104 R51 W600	FOR RITTAL VX25	Rev. no.	A.0 (DR)	Lang.	EN	Customer, Doc. No.	3AXD50000452576	21-May-19	Project name		Doc. No.	3AXD50000452576	Sheet	7	DNS Number	3AXD10000944501		Weight kg		ABB								Total				8
Based on	M. Michelsson	21-May-19	Title	ASSEMBLY DRAWING	Scale	1:10	Form	A3																																												
Customer	M. Michelsson	21-May-19	ACS880-104 R51 W600	FOR RITTAL VX25	Rev. no.	A.0 (DR)	Lang.	EN																																												
Customer, Doc. No.	3AXD50000452576	21-May-19	Project name		Doc. No.	3AXD50000452576	Sheet	7																																												
DNS Number	3AXD10000944501		Weight kg		ABB																																															
				Total				8																																												

Stage 7: Installation of du/dt filters

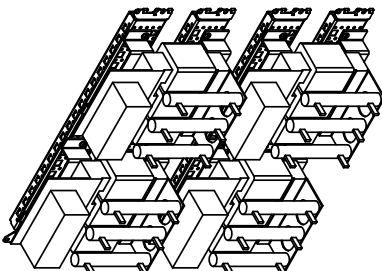
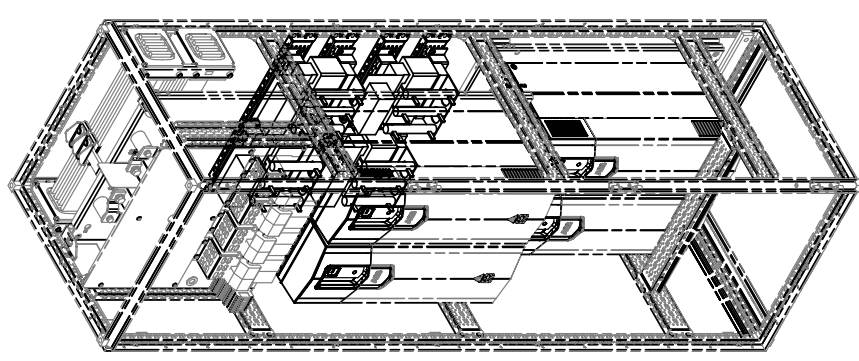
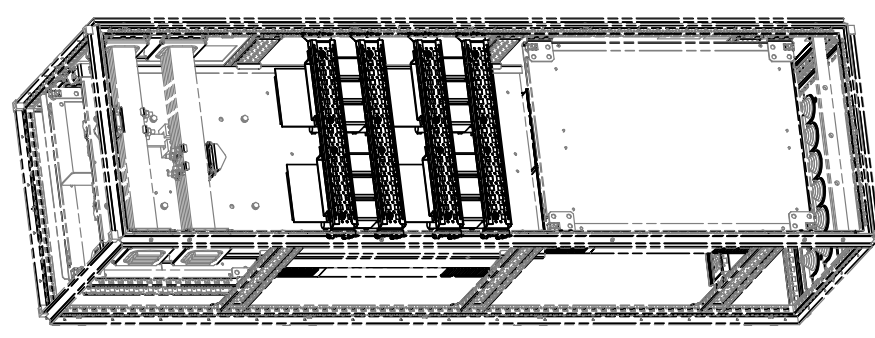
1	2	3	4	5	6	7	8
3AXD500045276 ACCESSORY FOR RITTAL ASSEMBLY DRAWING A Initial Approval							
We guarantee all rights in this document and in the information contained herein. Reproduction, use or disclosure of this document without express written authority is strictly forbidden. © ABB Ltd. PROPRIETARY AND SECURE INFORMATION. CONFIDENTIAL 21-May-19 M. Michelsson							
<p>STAGE 7: Du/Dt filter assembly (if applicable)</p> <p>See assembly drawing 3AXD5000462094 for details and required additional Rittal and standard parts</p>							
		<p style="text-align: center;">FRONT VIEW</p> 				<p style="text-align: center;">REAR VIEW</p> 	
First angle projection. Original drawing made with 3D CAD. Set the correct scale factor when adding dimensions after DWG/DWG conversion.							
Based on: Customer: M. Michelsson Date: 21-May-19 Project name: M. Michelsson Weight: kg: 3AXD1000394501		Prepared by: M. Michelsson Date: 21-May-19 Title: ASSEMBLY DRAWING FOR RITTAL V22		Checked by: M. Michelsson Date: 21-May-19 Title: ASSEMBLY DRAWING FOR RITTAL V22		Scale: Form: A3 Drawing: A3.0 Sheet: EN Total: 3	
Doc. No.: 3AXD5000045276		Rev. No.: 3AXD5000045276		Rev. No.: 3AXD5000045276		Rev. No.: 3AXD5000045276	



■ One R6i/R7i module in a 400 mm wide Rittal VX25 enclosure

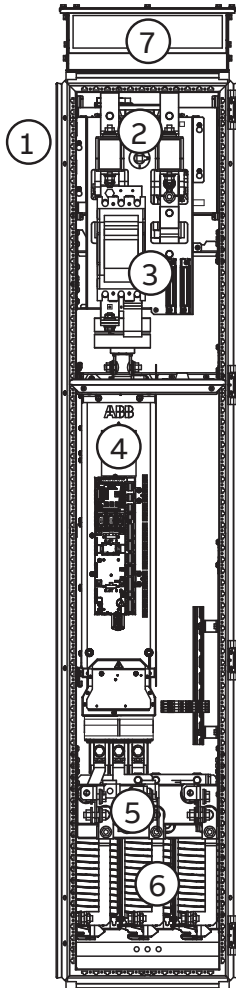

Description

Cubicle including:

1. DC bus
2. DC switch/disconnector and DC fuses
3. Charging contactor and resistors (frame R7i only)
4. Inverter module
5. AC output
6. du/dt filters (optional)
7. Air outlet



Installation stages

#	Installation stage	Instruction code	Kit code	Kit ordering code
1	Common parts:			
	Baying parts	3AXD50000336340	-	-
	PE busbars	3AXD50000336104	-	-
	Divider panel	3AXD50000336692	-	-
	DC busbars	3AXD50000333639	A-468-X-001-VX	3AXD50000333387
2	Bottom plate	-	-	-
3	Support beams	3AXD50000452934	-	-
4	DC busbars and charging components:			
	R6i without DC switch	3AXD50000444489	A-4-67-283-VX	3AXD50000459094
	R6i with DC switch (IEC)	3AXD50000445202	A-4-6-281-VX	3AXD50000459100
	R6i with DC switch (UL)	3AXD50000445325	A-4-6-285-VX	3AXD50000459117
	R7i without DC switch or charging	3AXD50000444489	A-4-67-283-VX	3AXD50000459094
	R7i without DC switch, with charging	3AXD50000445097	A-4-7-282-VX	3AXD50000459063
	R7i (400/500 V) with DC switch and charging	3AXD50000445257	A-4-7-280-VX	3AXD50000459056
	R7i (690 V) with DC switch and charging	3AXD50000445356	A-4-7-286-VX	3AXD50000459070
	R7i (690 V) without DC switch, with charging	3AXD50000445332	A-4-7-287-VX	3AXD50000459087
5	Common mode filters (filters not included in kit)	3AXD50000444304	A-4-67-241-VX	3AXD50000458509
6 A	AC busbars without output (du/dt) filters	3AXD50000452798	A-4-67-181-VX	3AXD50000459032
6 B	AC busbars with output (du/dt) filters	3AXD50000452439	A-4-67-186-VX	3AXD50000459049
7	Inverter module installation parts	3AXD50000453337	A-4-67-302-VX	3AXD50000459018
8	Shroud brackets	3AXD50000453252	A-4-67-350-VX	3AXD50000458493



Overview of kits



1	2	3	4	5	6	7	8
<p>3AXD5000045902 AC 380V-261-RT1-104-VX (ASSEM) - 9A Kit, DIN, updated Module with UCI-20 updated</p> <p style="font-size: small;">We reserve all rights in this document and in the information contained therein. Reproduction, use or disclosure of this document is strictly prohibited. © 2013, RITTAL AG, RITTAL R&D, RITTAL Production, 03-12-23, M. Mickelsson, 150002343206 03-12-23, J. Turkulainen</p>							
<p>KITS FOR INU R6i/R7i IN RITTAL VX25 2000x400x600 CABINET</p> <p>Note! Only parts included in ABB kits are shown here! See kit assembly drawings for required Rittal and/or standard parts.</p>							
A	B	C	D	E	F	G	H
<p>COMMON MODE FILTER BUSBARS R6i/R7i KIT A-4-67-241-VX Ordering code: 3AXD50000458509</p>							
<p>DC KIT FOR R6i/R7i WITH SWITCH KIT A-4-67-283-VX Ordering code: 3AXD50000459094</p>							
<p>DC KIT FOR R6i WITH SWITCH KIT A-4-6-281-VX Ordering code: 3AXD50000459100</p>							
<p>DC KIT FOR R6i WITH SWITCH UL KIT A-4-6-285-VX Ordering code: 3AXD50000459117</p>							
<p>DC KIT FOR R7i SWITCH AND CHARGING KIT A-4-7-280-VX Ordering code: 3AXD50000459056</p>							
<p>DC KIT FOR R7i WITH CHARGING KIT A-4-7-282-VX Ordering code: 3AXD50000459063</p>							
<p>DC KIT FOR 690V R7i SWITCH AND CHARGING KIT A-4-7-286-VX Ordering code: 3AXD50000459070</p>							
<p>DC KIT FOR 690V R7i WITH CHARGING KIT A-4-7-287-VX Ordering code: 3AXD50000459087</p>							
<p>OUTPUT (AC) BUSBAR KIT KIT A-4-67-181-VX Ordering code: 3AXD50000459032</p>							
<p>R6i/R7i DIV/OT FILTER BUSBARS KIT A-4-67-186-VX Ordering code: 3AXD50000459049</p>							
<p>BRACKET FOR FLAT-PLUS BUSBAR HOLDER COMMON DC-101-VX KIT A-4-68-VX-001-VX Ordering code: 3AXD50000333387</p>							
<p>R6i/R7i SHROUD INSTALLATION PARTS KIT A-4-67-350-VX Ordering code: 3AXD50000458493</p>							
<p>R6i/R7i MODULE INSTALLATION PARTS KIT A-4-67-302-VX Ordering code: 3AXD50000459018</p>							
<p>PREPARED BY: Prepared: J. Bulya Checked: M. Mickelsson Approved: M. Mickelsson Project name: 3AXD50000878870 Weight kg: 3AXD50000878870</p>							
<p>ABB ASSEMBLY DRAWING Title: ASSEMBLY DRAWING Part No.: 3AXD50000459032 Part Name: RITTAL VX25 Date: 03-12-23 Scale: 1:100 Unit: mm Sheet: 1 of 1 Total: 11</p>							

Stage 1: Installation of common parts

1	2	3	4	5	6	7	8
We reserve all rights in this document and in the information contained therein. Reproduction, use or disclosure in any manner without appropriate authority is strictly forbidden. © 2008 Schneider Electric. All rights reserved.							
Title: ASSEMBLY DRAWING Part: ACS800-R61-104.VX (ASSEMB) - 9 Rev. No.: 01 Date: 11-Mar-19 Author: I. Ruho Checked: M. Michelsson Approved: M. Michelsson Date: 01-Dec-23 Drawing No.: 500001263043 Rev. No.: 01 Date: 01-Dec-23 Author: M. Michelsson							
Note! See general cabinet engineering manual for common assembly principles. STAGE 1: Common assembly installations (Baying parts, PE Bus bar, Divider panel and Common DC) See assembly drawings for details.							
Baying parts assembly See drawing 3AXD50000336340							
Divider panel assembly See drawing 3AXD50000336692							
Common DC Flat-PLS assembly See drawing 3AXD50000336338							
PE bus bar design See drawing 3AXD50000336104							
Based on: I. Ruho Customer: M. Michelsson Checked: M. Michelsson Approved: M. Michelsson Date: 11-Mar-19 Drawing No.: 500001263043 Rev. No.: 01 Date: 01-Dec-23 Author: M. Michelsson							
Title: ASSEMBLY DRAWING Part: ACS800-R61R71-104 Rev. No.: 01 Date: 01-Dec-23 Author: M. Michelsson							
Scale: 1:10 A3 Form: A3 Drawing No.: 3AXD50000443932 Rev. No.: 01 Date: 11-Mar-19							



Stage 2: Installation of bottom plate



1	2	3	4	5	6	7	8																																					
<p>3AXD50000443932 B.11* ACS800-R61-RT1-104-VX (ASSEM) 1-9 Initial Approval Initial Dims updated</p>																																												
<p>Wiederholungsdruck ist nicht zulässig. Nachdruck ist ohne schriftliche Genehmigung der ABB AG, Pfaffenhofweg 1, 54002 Krefeld, Germany. 11-Mar-19 01-Dec-23 I. Ruho 5000128343 01-Dec-23 M. Michelsson</p>																																												
<p>First angle projection. Original drawing made with 3D CAD. Set the correct scale factor when adding dimensions after DWG/DXF conversion.</p>																																												
<p>STAGE 2: Bottom Plate installation (If required)</p> <p>Note! EMC cable lead-throughs should be used (not included in ABB delivery)</p>																																												
<table border="1" style="width: 100%; border-collapse: collapse;"> <tr> <td style="width: 25%;">Based on</td> <td style="width: 15%;">Prepared</td> <td style="width: 15%;">11-Mar-19</td> <td style="width: 15%;">Title</td> <td style="width: 15%;">ASSEMBLY DRAWING</td> <td style="width: 10%;">Scale</td> <td style="width: 10%;">Form</td> </tr> <tr> <td>Customer</td> <td>Checked</td> <td>01-Dec-23</td> <td>ACS800-R61/RT1-104</td> <td>ASSEMBLY DRAWING</td> <td>1:10</td> <td>A3</td> </tr> <tr> <td>Cust. Doc. No.</td> <td>Appr.</td> <td>01-Dec-23</td> <td>RITTAL VZ25</td> <td>Resp. appl.</td> <td>B (AP)</td> <td>Lang. EN</td> </tr> <tr> <td>DMS Number</td> <td>Project name</td> <td>Weight kg</td> <td colspan="4">Doc. No. 3AXD50000443932</td> <td>Sheet 3</td> </tr> <tr> <td></td> <td></td> <td></td> <td colspan="4">Total 11</td> <td></td> </tr> </table>								Based on	Prepared	11-Mar-19	Title	ASSEMBLY DRAWING	Scale	Form	Customer	Checked	01-Dec-23	ACS800-R61/RT1-104	ASSEMBLY DRAWING	1:10	A3	Cust. Doc. No.	Appr.	01-Dec-23	RITTAL VZ25	Resp. appl.	B (AP)	Lang. EN	DMS Number	Project name	Weight kg	Doc. No. 3AXD50000443932				Sheet 3				Total 11				
Based on	Prepared	11-Mar-19	Title	ASSEMBLY DRAWING	Scale	Form																																						
Customer	Checked	01-Dec-23	ACS800-R61/RT1-104	ASSEMBLY DRAWING	1:10	A3																																						
Cust. Doc. No.	Appr.	01-Dec-23	RITTAL VZ25	Resp. appl.	B (AP)	Lang. EN																																						
DMS Number	Project name	Weight kg	Doc. No. 3AXD50000443932				Sheet 3																																					
			Total 11																																									

Stage 3: Installation of support beams

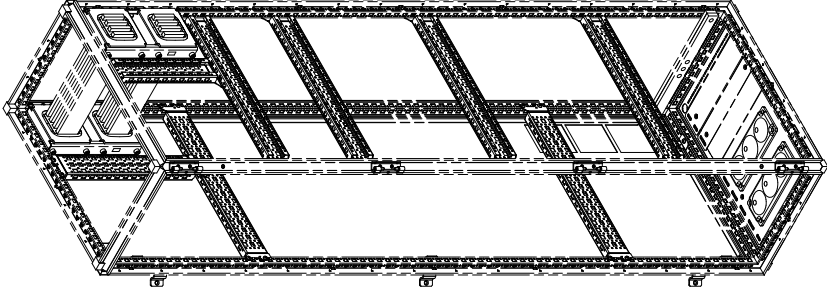
1	2	3	4	5	6	7	8																								
<p style="font-size: small;">We reserve all rights in this document if the information contained herein, reproduction, use or disclosure in any manner without appropriate authority is strictly forbidden. © 2004 Schneider Electric. All rights reserved. 11-Mar-19 I. Ruho 500001283043 01-Dec-23 M. Michelsson</p>																															
<p style="font-size: small;">First angle projection. Original drawing made with 3D CAD. Set the correct scale factor when adding dimensions after DWG/DXF conversion.</p>																															
<p>3AXD5000043932 ACS800-R61-R71-104.VK (ASSEMB) - 3 Initial Approval Kit DPMs updated</p>																															
<p>STAGE 3: Rittal supports installation for INU R61/R71 See assembly drawing 3AXD50000452934 for details.</p>																															
																															
<table border="1" style="width: 100%; border-collapse: collapse; font-size: x-small;"> <tr> <td style="width: 25%;">Based on</td> <td style="width: 25%;">I. Ruho</td> <td style="width: 25%;">11-Mar-19</td> <td style="width: 25%;">Title ASSEMBLY DRAWING</td> </tr> <tr> <td>Customer</td> <td>M. Michelsson</td> <td>01-Dec-23</td> <td>ACS800-R61/R71-104</td> </tr> <tr> <td>Drawn by</td> <td>M. Michelsson</td> <td>01-Dec-23</td> <td>RITTAL VZ35</td> </tr> <tr> <td>Checked by</td> <td>M. Michelsson</td> <td>01-Dec-23</td> <td></td> </tr> <tr> <td>Customer No.</td> <td>3AXD10000878870</td> <td></td> <td></td> </tr> <tr> <td>DWG Number</td> <td></td> <td></td> <td></td> </tr> </table>								Based on	I. Ruho	11-Mar-19	Title ASSEMBLY DRAWING	Customer	M. Michelsson	01-Dec-23	ACS800-R61/R71-104	Drawn by	M. Michelsson	01-Dec-23	RITTAL VZ35	Checked by	M. Michelsson	01-Dec-23		Customer No.	3AXD10000878870			DWG Number			
Based on	I. Ruho	11-Mar-19	Title ASSEMBLY DRAWING																												
Customer	M. Michelsson	01-Dec-23	ACS800-R61/R71-104																												
Drawn by	M. Michelsson	01-Dec-23	RITTAL VZ35																												
Checked by	M. Michelsson	01-Dec-23																													
Customer No.	3AXD10000878870																														
DWG Number																															
<table border="1" style="width: 100%; border-collapse: collapse; font-size: x-small;"> <tr> <td style="width: 25%;">Doc. det.</td> <td style="width: 25%;">ASSEMBLY DRAWING</td> <td style="width: 25%;">Scale</td> <td style="width: 25%;">Form</td> </tr> <tr> <td>Doc. app.</td> <td></td> <td></td> <td>1:10 A3</td> </tr> <tr> <td>Doc. No.</td> <td>3AXD50000443932</td> <td>Rev. No.</td> <td>B (AP)</td> </tr> <tr> <td></td> <td></td> <td>Rev. Date</td> <td>2004 11</td> </tr> </table>								Doc. det.	ASSEMBLY DRAWING	Scale	Form	Doc. app.			1:10 A3	Doc. No.	3AXD50000443932	Rev. No.	B (AP)			Rev. Date	2004 11								
Doc. det.	ASSEMBLY DRAWING	Scale	Form																												
Doc. app.			1:10 A3																												
Doc. No.	3AXD50000443932	Rev. No.	B (AP)																												
		Rev. Date	2004 11																												



Stage 4 (R6i): Installation of DC busbars and charging components

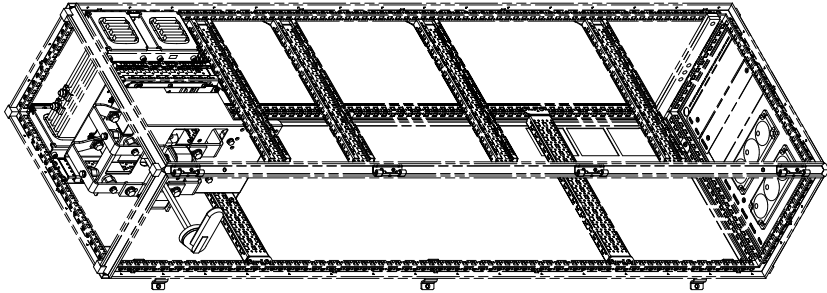
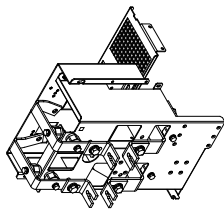
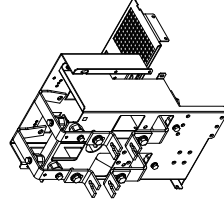
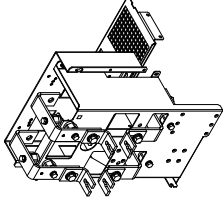

1	2	3	4	5	6	7	8																																								
B.11 3AXD50000443932 ACS800-R6i/R7i-104-VX (ASSEMBLY) - 9 INITIAL APPROVAL KIT DIMS UPDATED																																															
We hereby certify that the information on this drawing is correct and complete. Reproduction, modification or use of this drawing without the written consent of ABB is prohibited.																																															
11-Mar-19		11-Mar-19		11-Mar-19		11-Mar-19																																									
01-Dec-23		01-Dec-23		01-Dec-23		01-Dec-23																																									
J. Reba		J. Reba		J. Reba		J. Reba																																									
M. Michalsson		M. Michalsson		M. Michalsson		M. Michalsson																																									
M. Asikainen		M. Asikainen		M. Asikainen		M. Asikainen																																									
50000783043		50000783043		50000783043		50000783043																																									
First angle projection. Original drawing made with 3D CAD. Set the correct scale factor when adding dimensions after DWG/DXF conversion.																																															
<p>STAGE 4A: DC KIT FOR R6i WITH SWITCH installation See assembly drawing 3AXD50000445202 for details.</p> <p>DC KIT FOR R6i WITH SWITCH UL installation See assembly drawing 3AXD5000045325 for details.</p>																																															
																																															
<p>DC KIT FOR R6i WITH SWITCH Ordering code: 3AXD50000459100 KIT A-4-6-281-VX</p>		<p>DC KIT FOR R6i WITH SWITCH Ordering code: 3AXD50000459117 KIT A-4-6-283-VX</p>		<p>DC KIT FOR R6i/R7i FUSES ONLY Ordering code: 3AXD50000459094 KIT A-4-67-283-VX</p>		<p>For solutions with UL DC-switch and fuses</p>																																									
<p>See drawings for required Rittal and/or other standard parts.</p>																																															
<table border="1" style="width: 100%; border-collapse: collapse; font-size: x-small;"> <tr> <td>Based on</td> <td>Prepared</td> <td>I. Reba</td> <td>11-Mar-19</td> <td>Title</td> <td>ASSEMBLY DRAWING</td> <td>Scale</td> <td>Form</td> </tr> <tr> <td>Customer</td> <td>Checked</td> <td>M. Michalsson</td> <td>01-Dec-23</td> <td>ACCS800-R6i/R7i-104</td> <td>ASSEMBLY DRAWING</td> <td>1:10</td> <td>A3</td> </tr> <tr> <td>Cust. Doc. No.</td> <td>Appr.</td> <td>M. Asikainen</td> <td>01-Dec-23</td> <td>RITTAL VX25</td> <td>Res. appl.</td> <td>B (AP)</td> <td>Lang. EN</td> </tr> <tr> <td>DMS Number</td> <td>Weight</td> <td>kg</td> <td></td> <td>Doc. No.</td> <td>3AXD50000443932</td> <td>Sheet</td> <td>Total</td> </tr> <tr> <td>3AXD10000876870</td> <td></td> <td></td> <td></td> <td></td> <td></td> <td>5</td> <td>11</td> </tr> </table>								Based on	Prepared	I. Reba	11-Mar-19	Title	ASSEMBLY DRAWING	Scale	Form	Customer	Checked	M. Michalsson	01-Dec-23	ACCS800-R6i/R7i-104	ASSEMBLY DRAWING	1:10	A3	Cust. Doc. No.	Appr.	M. Asikainen	01-Dec-23	RITTAL VX25	Res. appl.	B (AP)	Lang. EN	DMS Number	Weight	kg		Doc. No.	3AXD50000443932	Sheet	Total	3AXD10000876870						5	11
Based on	Prepared	I. Reba	11-Mar-19	Title	ASSEMBLY DRAWING	Scale	Form																																								
Customer	Checked	M. Michalsson	01-Dec-23	ACCS800-R6i/R7i-104	ASSEMBLY DRAWING	1:10	A3																																								
Cust. Doc. No.	Appr.	M. Asikainen	01-Dec-23	RITTAL VX25	Res. appl.	B (AP)	Lang. EN																																								
DMS Number	Weight	kg		Doc. No.	3AXD50000443932	Sheet	Total																																								
3AXD10000876870						5	11																																								

Stage 4 (R7i): Installation of DC busbars and charging components

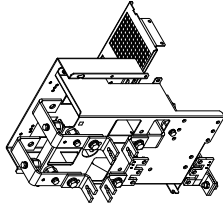
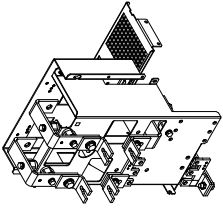
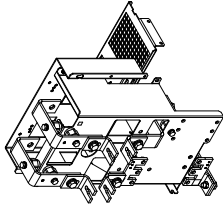
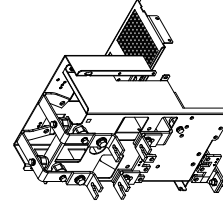
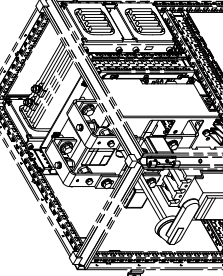
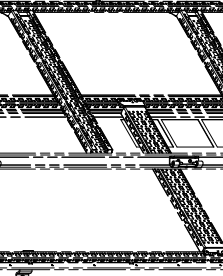
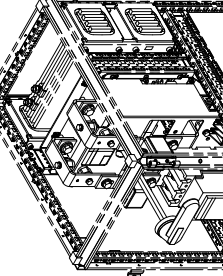
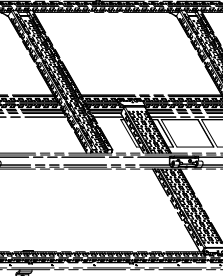
1	2	3	4	5	6	7	8
<p>3AXD5000043932 [B.1.] ACS800-R6i-R7i-(04-VX (ASSEMB)) -3 Kit DPMs updated</p>							
<p>11-Mar-19 I. Ruha 500001282043 01-Dec-23 M. Michelsson</p>							
<p>Warranty: We reserve all rights in this document and in the information contained herein. Reproduction, use or disclosure in any form without approval of the manufacturer is strictly forbidden. 11-Mar-19 I. Ruha 500001282043 01-Dec-23 M. Michelsson</p>							
<p>STAGE 4B: DC KIT FOR R7i SWITCH AND CHARGING installation See assembly drawing 3AXD50000445257 for details.</p>							
<p>DC KIT FOR R7i SWITCH AND CHARGING Ordering code: 3AXD50000459056 KIT A-4-7-280-VX For solutions with DC-switch, fuses and charging</p>							
<p>DC KIT FOR 690V R7i SWITCH AND CHARGING installation See assembly drawing 3AXD50000445356 for details.</p>							
<p>DC KIT FOR 690V R7i SWITCH AND CHARGING Ordering code: 3AXD50000459070 KIT A-4-7-286-VX For solutions with DC-switch, fuses and charging</p>							
<p>DC KIT FOR R7i WITH CHARGING installation See assembly drawing 3AXD50000445097 for details.</p>							
<p>DC KIT FOR 690V R7i WITH CHARGING installation See assembly drawing 3AXD50000445332 for details.</p>							
<p>DC KIT FOR R7i WITH CHARGING Ordering code: 3AXD50000459063 KIT A-4-7-282-VX For solutions with charging and fuses</p>							
<p>DC KIT FOR 690V R7i WITH CHARGING Ordering code: 3AXD50000459087 KIT A-4-7-287-VX For solutions with charging and fuses</p>							
<p>See drawings for required Rittal and/or other standard parts.</p>							
							
							
							
							
							
							
							
							
<p>Based on: I. Ruha 11-Mar-19 Checked: M. Michelsson 01-Dec-23 Approved: M. Michelsson 01-Dec-23 Drawn: M. Michelsson 01-Dec-23 DPM Number: 3AXD10000878870 Revision: 01</p>							
<p>Doc. det.: ASSEMBLY DRAWING Scale: 1:10 A3 Doc. No.: 3AXD50000443932 Title: ACS800-R6i/R7i-104 RITTAL VXS Form: I 10 A3 Links: EN Total: 11</p>							



Stage 5: Installation of common mode filters



1	2	3	4	5	6	7	8
3AXD50000443932 ACS800-R6i/R7i-104-VX (ASSEM) 1-9 Initial Approval KIT DIMS UPDATED							
We warrant that the information on this drawing is correct and complete for the intended application. We do not warrant that the information on this drawing is correct and complete for any other application. We do not warrant that the information on this drawing is correct and complete for any other application. We do not warrant that the information on this drawing is correct and complete for any other application.							
Prepared: I. Rebo Checked: M. Michalsson Appr.: M. Asikainen		11-Mar-19 01-Dec-23 01-Dec-23		Title: ASSEMBLY DRAWING ACS800-R6i/R7i-104 RITTAL VX25		Dec. des.: ASSEMBLY DRAWING Resp. des.: B (AP) Doc. No.: 3AXD50000443932	
Based on: Customer: Cust. Doc. No.: DMS Number:		11-Mar-19 01-Dec-23 01-Dec-23		Title: ASSEMBLY DRAWING ACS800-R6i/R7i-104 RITTAL VX25		Scale: 1:10 A3 Rev. No.: B (AP) Doc. No.: 3AXD50000443932	
Weight: 50001783043 I. Rebo M. Michalsson		01-Dec-23 M. Michalsson		01-Dec-23 M. Asikainen		3AXD50000443932 7 11	

STAGE 5: COMMON MODE FILTER BUSBARS R6i/R7i installation

See assembly drawing 3AXD50000444304 for details and required additional Rittal and standard parts.

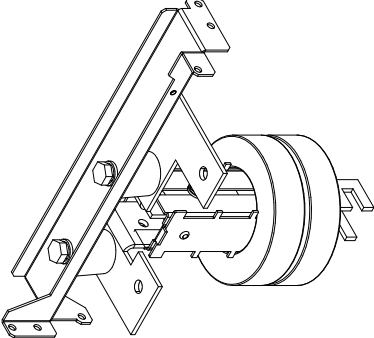

Ordering code: 3AXD50000458509
 Toroids not included in kit
 KIT A-4-67-241-VX

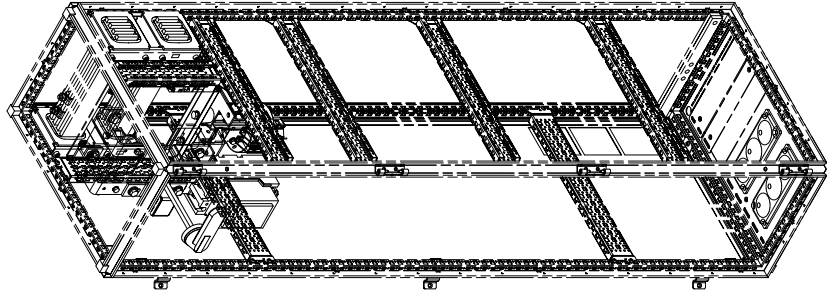

Stage 6 A: Installation of AC busbars (without du/dt filters)

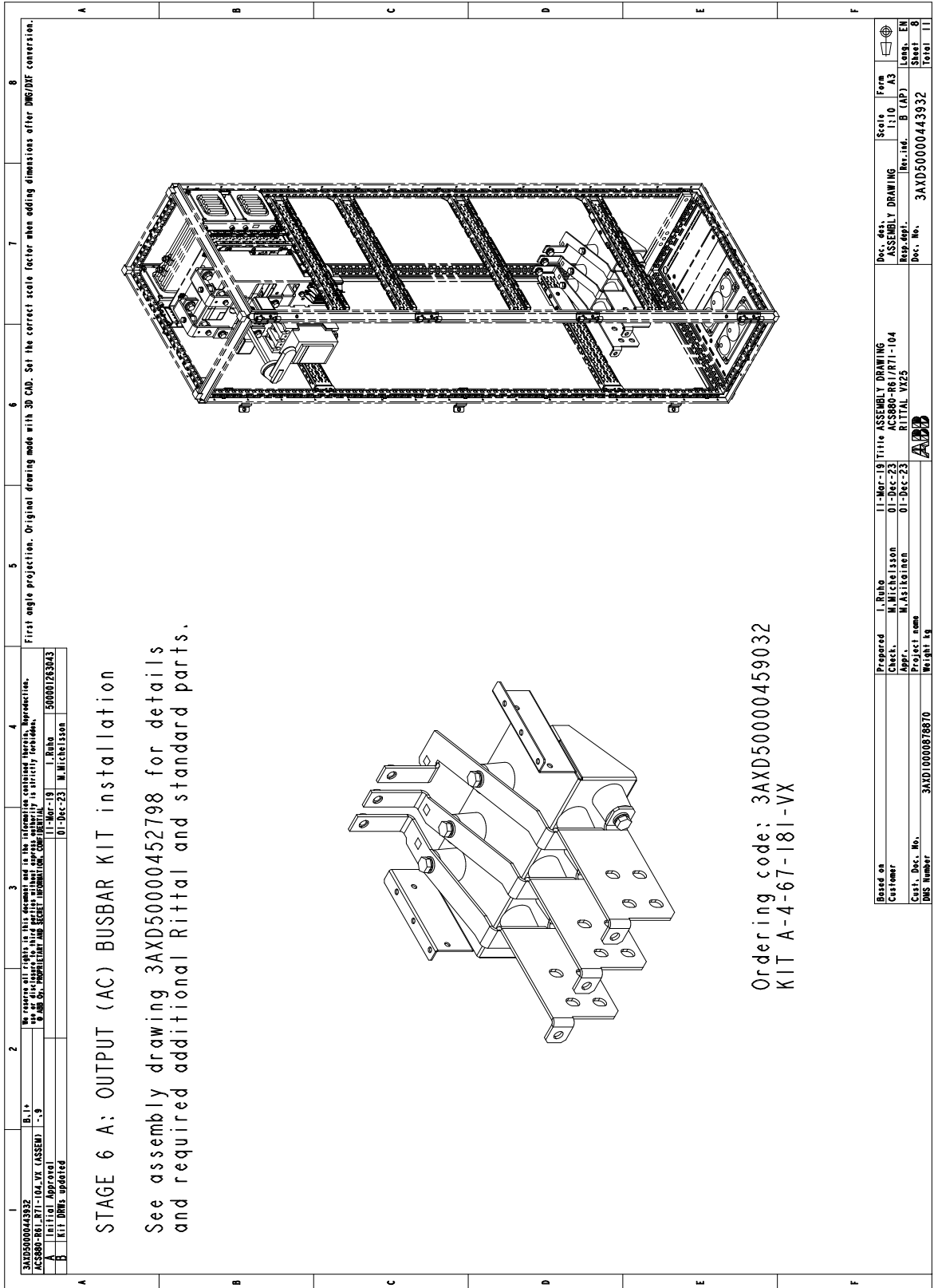

3AXD5000043932
 ACS800-R61-KIT-104-VX (ASSEMB) - 3
 B.1.
 Initial Approval
 Kit DRMs updated

2 We reserve all rights in this document and in the information contained herein. Reproduction, use or disclosure in any form without appropriate authority is strictly forbidden.
 © 2018 Schneider Electric. All rights reserved.
 11-Mar-19 I. Ruho 500001283043
 01-Dec-23 M. Michelsson

4 First angle projection. Original drawing made with 3D CAD. Set the correct scale factor when adding dimensions after DWG/DXF conversion.

STAGE 6 A: OUTPUT (AC) BUSBAR KIT installation

See assembly drawing 3AXD50000452798 for details and required additional Rittal and standard parts.

Ordering code: 3AXD50000459032
 KIT A-4-67-181-VX

Based on	Prepared	I. Ruho	11-Mar-19	Title	ASSEMBLY DRAWING	Scale	Form
Customer	Checked	M. Michelsson	01-Dec-23	ACS800-R61/R71-104	ASSEMBLY DRAWING	1:10	A3
Client	Approved	M. Michelsson	01-Dec-23	RITTAL V4Z5	Rev. No.	B (AP)	Links
Customer	Approved	M. Michelsson	01-Dec-23		Doc. No.	3AXD50000443932	EN
Customer	Approved	M. Michelsson	01-Dec-23		Doc. No.	3AXD50000443932	11



Stage 6 B: Installation of AC busbars (with du/dt filters)



1	2	3	4	5	6	7	8																																			
<p>STAGE 6 B: R6i/R7i DU/DT FILTER BUSBARS installation</p> <p>See assembly drawing 3AXD50000452439 for details and required additional Rittal and standard parts.</p>																																										
<p>Ordering code: 3AXD50000459049 KIT A-4-67-186-VX</p>																																										
<table border="1" style="width: 100%; border-collapse: collapse;"> <tr> <td style="width: 15%;">Based on</td> <td style="width: 15%;">I. Reub</td> <td style="width: 15%;">11-Mar-19</td> <td style="width: 15%;">Title</td> <td style="width: 15%;">ASSEMBLY DRAWING</td> <td style="width: 10%;">Scale</td> <td style="width: 10%;">Form</td> </tr> <tr> <td>Customer</td> <td>M. Michalison</td> <td>01-Dec-23</td> <td>ACC800-R6i/R7i-104</td> <td>ASSEMBLY DRAWING</td> <td>1:10</td> <td>A3</td> </tr> <tr> <td>Appr.</td> <td>M. Asikainen</td> <td>01-Dec-23</td> <td>RITTAL VX25</td> <td>Resp. Appl.</td> <td>B (AP)</td> <td>EN</td> </tr> <tr> <td>Cust. Doc. No.</td> <td></td> <td></td> <td></td> <td>Doc. No.</td> <td>3AXD50000443932</td> <td>Sheet 9</td> </tr> <tr> <td>DMS Number</td> <td>3AXD10000878870</td> <td>Weight</td> <td>kg</td> <td></td> <td></td> <td>Total 11</td> </tr> </table>								Based on	I. Reub	11-Mar-19	Title	ASSEMBLY DRAWING	Scale	Form	Customer	M. Michalison	01-Dec-23	ACC800-R6i/R7i-104	ASSEMBLY DRAWING	1:10	A3	Appr.	M. Asikainen	01-Dec-23	RITTAL VX25	Resp. Appl.	B (AP)	EN	Cust. Doc. No.				Doc. No.	3AXD50000443932	Sheet 9	DMS Number	3AXD10000878870	Weight	kg			Total 11
Based on	I. Reub	11-Mar-19	Title	ASSEMBLY DRAWING	Scale	Form																																				
Customer	M. Michalison	01-Dec-23	ACC800-R6i/R7i-104	ASSEMBLY DRAWING	1:10	A3																																				
Appr.	M. Asikainen	01-Dec-23	RITTAL VX25	Resp. Appl.	B (AP)	EN																																				
Cust. Doc. No.				Doc. No.	3AXD50000443932	Sheet 9																																				
DMS Number	3AXD10000878870	Weight	kg			Total 11																																				

Stage 7: Installation of inverter module

1	2	3	4	5	6	7	8																																																																								
<p>3AXD5000043932 ACS880-R61-R7i-10A-VX (ASSEMBLY) - 9*</p> <p>R+H Drills updated Module with UC0-20 updated</p> <p style="font-size: small;">C.O. C.0* We reserve all rights in this document. In the event of any discrepancy between the original and this representation, the original shall prevail. © ABB. All rights reserved. ABB is a registered trademark of ABB. All other trademarks are the property of their respective owners.</p> <p style="font-size: x-small;">01-Dec-23 J. Michelsson 150002349206 03-Dec-25 J. Trankkainen</p>																																																																															
<p>STAGE 7: R6i/R7i MODULE INSTALLATION PARTS installation</p> <p>See assembly drawing 3AXD50000453337 for details and required additional Rittal and standard parts.</p>																																																																															
<p>MODULE NOT INCLUDED IN KIT</p>																																																																															
<p>IF NEEDED, FOR EXAMPLE FOR CONTROL ELECTRONICS NOT INCLUDED IN KIT</p>																																																																															
<p>Ordering code: 3AXD50000459018 KIT A-4-67-302-VX</p>																																																																															
<p>SEAL THE GAPS BETWEEN THE FRAMES AND SUPPORTS AND AIR BLOCKERS TO AVOID HOT AIR BACKFLOW FROM THE MODULE</p>																																																																															
<table border="1" style="width: 100%; border-collapse: collapse;"> <tr> <td style="width: 15%;">Based on</td> <td style="width: 15%;">E. Ruha</td> <td style="width: 15%;">11-Mar-19</td> <td style="width: 15%;">Title</td> <td style="width: 15%;">ASSEMBLY DRAWING</td> <td style="width: 15%;">Scale</td> <td style="width: 15%;">I:10</td> <td style="width: 15%;">AS</td> </tr> <tr> <td>Customer</td> <td>M. Michelsson</td> <td>03-Dec-23</td> <td>ACS880-R61/R7i-104</td> <td>ASSEMBLY DRAWING</td> <td>Rev. no.</td> <td>C.O. (AP)</td> <td>Form</td> </tr> <tr> <td>Appr.</td> <td>M. Asikainen</td> <td>03-Dec-25</td> <td>RITTAL VX25</td> <td>Rev. no.</td> <td>C.O. (AP)</td> <td>Long.</td> <td>EN</td> </tr> <tr> <td>Project name</td> <td colspan="7"></td> </tr> <tr> <td>DWG Number</td> <td>3AXD100008788/0</td> <td colspan="6"></td> </tr> <tr> <td>Doc. No.</td> <td colspan="7"></td> </tr> <tr> <td>Doc. No.</td> <td colspan="7">3AXD50000443932</td> </tr> <tr> <td>Sheet 10</td> <td colspan="7"></td> </tr> <tr> <td>Total 11</td> <td colspan="7"></td> </tr> </table>								Based on	E. Ruha	11-Mar-19	Title	ASSEMBLY DRAWING	Scale	I:10	AS	Customer	M. Michelsson	03-Dec-23	ACS880-R61/R7i-104	ASSEMBLY DRAWING	Rev. no.	C.O. (AP)	Form	Appr.	M. Asikainen	03-Dec-25	RITTAL VX25	Rev. no.	C.O. (AP)	Long.	EN	Project name								DWG Number	3AXD100008788/0							Doc. No.								Doc. No.	3AXD50000443932							Sheet 10								Total 11							
Based on	E. Ruha	11-Mar-19	Title	ASSEMBLY DRAWING	Scale	I:10	AS																																																																								
Customer	M. Michelsson	03-Dec-23	ACS880-R61/R7i-104	ASSEMBLY DRAWING	Rev. no.	C.O. (AP)	Form																																																																								
Appr.	M. Asikainen	03-Dec-25	RITTAL VX25	Rev. no.	C.O. (AP)	Long.	EN																																																																								
Project name																																																																															
DWG Number	3AXD100008788/0																																																																														
Doc. No.																																																																															
Doc. No.	3AXD50000443932																																																																														
Sheet 10																																																																															
Total 11																																																																															



Stage 8: Installation of shrouding brackets



1	2	3	4	5	6	7	8
<p>STAGE 8: R6i/R7i SHROUD INSTALLATION PARTS installation</p> <p>See assembly drawing 3AXD50000453252 for details and required additional Rittal and standard parts.</p>							
<p>Ordering code: 3AXD50000458493 KIT A-4-67-350-VX</p>							
<p>Based on: Prepared: I. Reub 11-Mar-19 Title: ASSEMBLY DRAWING Scale: Form Customer: M. Michelsson 01-Dec-23 ACC800-R6i/R7i-104 A3 Checked: M. Michelsson 01-Dec-23 RITTAL VX25 Rev. no. B (AP) Long. EN Approved: M. Asikainen 01-Dec-23 Doc. No. 3AXD50000443932 Sheet 11 Project name: Weight kg DMS Number: 3AXD10000878870</p>							
<p>Doc. des. ASSEMBLY DRAWING Scale: Form Resp. appl. Rev. no. B (AP) Long. EN Doc. No. 3AXD50000443932 Sheet 11 Total 11</p>							

First angle projection. Original drawing made with 3D CAD. Set the correct scale factor when adding dimensions after DWG/DXF conversion.

Wiederholungsrechte vorbehalten. Nachdruck, Vervielfältigung und Verbreitung, auch auszugsweise, ist ohne schriftliche Genehmigung.
Rittal GmbH & Co. KG, Industriestraße 31, 36083 Bielefeld, Germany
11-Mar-19 01-Dec-23 M. Michelsson 5000128243

■ **One R6i/R7i module in a 400 mm wide generic enclosure**

Parts installed	Instruction code	Kit code	Kit ordering code
R6i with DC switch (IEC)	3AXD50000445202	A-4-6-281-VX	3AXD50000459100
R6i with DC switch (UL)	3AXD50000445325	A-4-6-285-VX	3AXD50000459117
R7i without DC switch, with charging	3AXD50000445097	A-4-7-282-VX	3AXD50000459063
R7i (400/500 V) with DC switch and charging	3AXD50000445257	A-4-7-280-VX	3AXD50000459056
R7i (690 V) with DC switch and charging	3AXD50000445356	A-4-7-286-VX	3AXD50000459070
R7i (690 V) without DC switch, with charging	3AXD50000445332	A-4-7-287-VX	3AXD50000459087
Common mode filters (filters not included in kit)	3AXD50000444304	A-4-67-241-VX	3AXD50000458509
Generic common mode filter kit	3AXD50000023500	A-0-67-244	3AXD50000023329
AC busbars without output (du/dt) filters	3AXD50000452798	A-4-67-181-VX	3AXD50000459032
AC busbars with output (du/dt) filters	3AXD50000452439	A-4-67-186-VX	3AXD50000459049



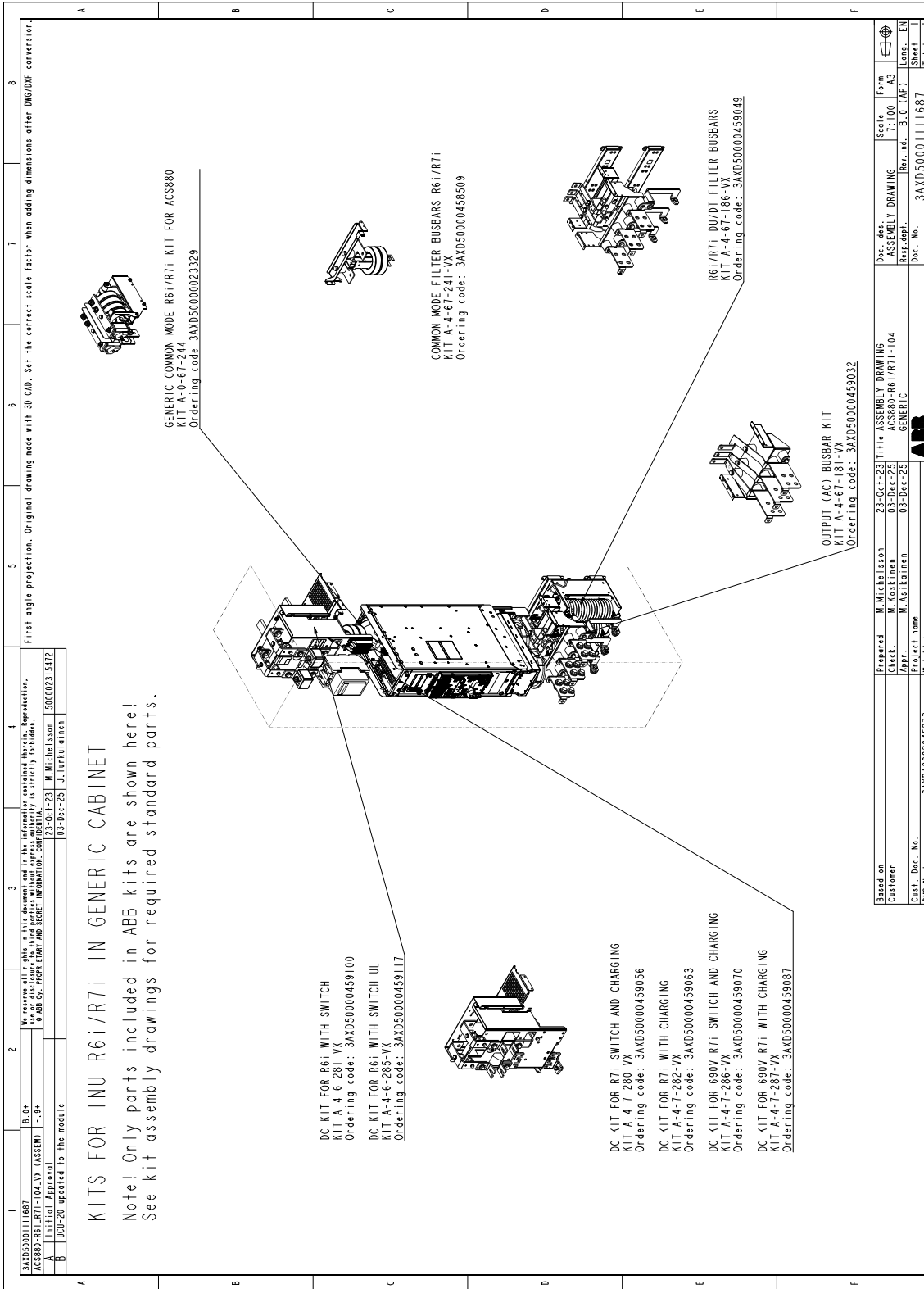

■ One R8i module in a 400 mm wide Rittal VX25 enclosure

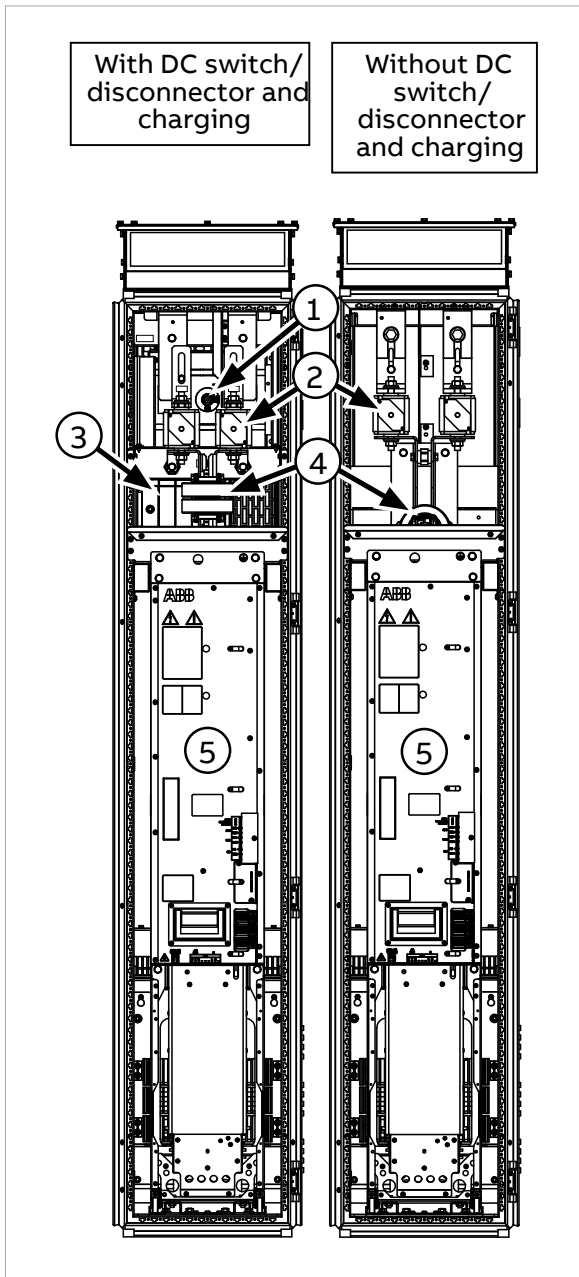

Description

Cubicle including:

1. DC switch/disconnector (obscured)
2. DC fuses
3. Charging switch
4. Common mode filters
5. Inverter module



Installation stages

#	Installation stage	Instruction code	Kit code	Kit ordering code
1	Common parts:			
	Baying parts	3AXD50000336340	-	-
	PE busbar	3AXD50000336104	-	-
	Divider panel	3AXD50000336692	-	-
	DC busbars	3AXD50000333639	A-468-X-001-VX	3AXD50000333387
2 A	DC connection 1 of 2 (from DC bus to DC fuses) without DC switch/charging:			
	Busbar assembly	3AXD50000345151	A-4-8-252-VX	3AXD50000337415
	Busbars	3AXD50000345915	A-46-8-206-VX	3AXD50000337446
2 B	DC connection 1 of 2 (from DC bus to DC fuses) with DC switch/charging:			
	DC switch/charging mechanics	3AXD50000342501	A-4-8-288-VX	3AXD50000337439
	Busbar assembly	3AXD50000345236	A-4-8-290-VX	3AXD50000337422
	Busbars	3AXD50000345458	A-46-8-207-VX	3AXD50000337453
3	Module mechanical installation parts, lead-throughs:			
	Module top/bottom guides	3AXD50000335152	A-4-8-310-VX	3AXD50000337071
	Lead-throughs	3AXD50000004817	A-468-8-441	3AXD50000004385
4 A	Quick connector, output (AC) busbars (cable connection):			
	Quick connector	3AUA0000118667	A-468-8-100	3AUA0000119227
	Busbars and shrouds	3AXD50000343492	A-4-8-132-VX	3AXD50000337477
4 B	Quick connector, output (AC) busbars (common AC output busbar connection):			
	Quick connector	3AUA0000118667	A-468-8-100	3AUA0000119227
	Busbars and shrouds	3AXD50000343928	A-4-8-140-VX	3AXD50000337088
5 A	DC connection 2 of 2 (from DC fuses to inverter module) without DC switch/charging:			
	DC connection flanges	3AXD50000028384	A-468-8-246	3AXD50000028403
	DC busbars with common mode filters (filters not included in kit)	3AXD50000028418	A-468-8-235	3AXD50000028401
5 B	DC connection 2 of 2 (from DC fuses to inverter module) with DC switch/charging:			
	DC connection flanges	3AXD50000043466	A-468-8-248	3AXD50000044553
	DC busbars with common mode filters (filters not included in kit)	3AXD50000043411	A-468-8-247	3AXD50000044551
6	Shrouding	3AXD50000335169	A-4-8-359-VX	3AXD50000337484
7	Inverter module	-	-	-



Overview of kits

12345678

ABCDEF

3AXD5000037453
ACSB00104181-W400-VX25-ASSEMBLY KIT

We reserve all rights in this document and in the information contained herein. Reproduction, use or disclosure of this document without express authority is strictly forbidden.
© ABB Ltd. PROPRIETARY AND SECURE INFORMATION. CONFIDENTIAL

02-Apr-19 M. Michelsson

Initial Approval

Prepared by: M. Michelsson 02-Apr-19
Checked by: M. Michelsson 04-Apr-19
Approved by: M. Michelsson 02-Apr-19

Title: ASSEMBLY DRAWING
Part No.: 04-1025
For RITTAL VXE2

Weight: kg
3AXD1000030254

Doc. No.: 3AXD50000337453
Title: ASSEMBLY DRAWING
Part No.: 04-1025
For RITTAL VXE2

Scale: Form
1:100 A3

Rev. No.: 3AXD50000342594
Rev. No.: 3AXD50000337453
Rev. No.: 3AXD50000337453
Rev. No.: 3AXD50000337453

KITS FOR INU IXR8i IN RITTAL VX25 2000x600x400 CABINET

Note! Only parts included in ABB kits are shown here.
See kit assembly drawings for required Rittal and/or other standard parts.

R8i SHROUD INST. PARTS W400
KIT A-4-8-359-VX
Ordering code: 3AXD50000337484

R8i DC FLANGES (FLUSE ONLY)
KIT A-468-8-246
Ordering code: 3AXD5000028403

R8i DC FLANGES CHARG.
KIT A-468-8-248
Ordering code: 3AXD5000044553

R8i COMMON MODE BUSBARS (FLUSE ONLY)
KIT A-468-8-235
Ordering code: 3AXD5000028401

R8i COMMON MODE BUSBARS CHARG.
KIT A-468-8-247
Ordering code: 3AXD5000044551

R8i DC CONNECTION
KIT A-46-8-206-VX
Ordering code: 3AXD50000337446

R8i INU DC CONNECTION W. CHARG.
KIT A-46-8-207-VX
Ordering code: 3AXD50000337453

R8i INU CHARG. MECHANICS W400
KIT A-4-8-288-VX
Ordering code: 3AXD50000337439

BRACKET FOR FLAT-PLS BUSBAR HOLDER (COMMON DC)
KIT A-468-K-001-VX
Ordering code: 3AXD50000333387

R8i DC BUSBARS W400 (FLUSE ONLY)
KIT A-4-8-252-VX
Ordering code: 3AXD50000337415

R8i DC BUSBARS W400 CHARG.
KIT A-4-8-290-VX
Ordering code: 3AXD50000337422

R8i AC OUTPUT BUSBARS W400
KIT A-4-8-132-VX
Ordering code: 3AXD50000337472

R8i AC OUTPUT BUSBARS W400
KIT A-4-8-140-VX
Ordering code: 3AXD50000337088

R8i COMMON AC OUTPUT BUSBARS W400
KIT A-4-8-140-VX
Ordering code: 3AXD50000337088

R8i X8X QUICK CONNECTORS FOR MODULE
KIT A-468-8-100
Ordering code: 3AUA0000119227

R8i LEAD-THROUGH FOR BOTTOM PLATE
KIT A-468-8-441
Ordering code: 3AXD50000004385

R8i MODULE INST PARTS W400
KIT A-4-8-310-VX
Ordering code: 3AXD50000337071

Based on: M. Michelsson 02-Apr-19
Customer: M. Michelsson 04-Apr-19
Project name: M. Michelsson 02-Apr-19
Weight: kg
3AXD1000030254

Prepared by: M. Michelsson 02-Apr-19
Checked by: M. Michelsson 04-Apr-19
Approved by: M. Michelsson 02-Apr-19

Title: ASSEMBLY DRAWING
Part No.: 04-1025
For RITTAL VXE2

Scale: Form
1:100 A3

Rev. No.: 3AXD50000342594
Rev. No.: 3AXD50000337453
Rev. No.: 3AXD50000337453
Rev. No.: 3AXD50000337453



Stage 1: Installation of common parts



1	2	3	4	5	6	7	8
A	B	C	D	E	F		

3AXD50000342594
AC5880-104-R81-W400-VZ25 (ASSEMBLY)
A.1.1
Initial Approval
02-Apr-19 M. Michelsson

We reserve all rights in this document and in the information contained herein. Reproduction, storage in retrieval systems, or transmission in any form or by any means, electronic, mechanical, photocopying, recording, or otherwise, is strictly forbidden.
© ABB. ALL INFORMATION CONTAINED HEREIN IS UNCLASSIFIED.

Note! See general engineering cabinet manual for common assembly principles

STAGE 1: Common assembly installations (Baying parts, PE bus bar, Divider panel, and Common DC). See assembly drawings for details

Based on	Prepared	M. Michelsson	02-Apr-19	Title	ASSEMBLY DRAWING	Scale	1:10	Form	A3
Customer	Check.	M. Michelsson	02-Apr-19	AC5880-104-R81-W400	ASSEMBLY DRAWING	Rev.ind.	A.1.1 (DE)	Lang.	EN
Customer	Appr.	M. Asikainen	02-Apr-19	FOR RITVAL VZ25		Doc. No.	3AXD50000342594	Sheet	2
DMS Number	3AXD1000909254		Weight kg		ABB				
Total 11									

Stage 2 A: Installation of DC busbars (1) (without DC switch/charging)

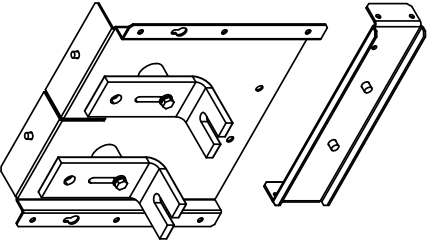
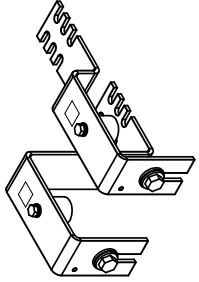
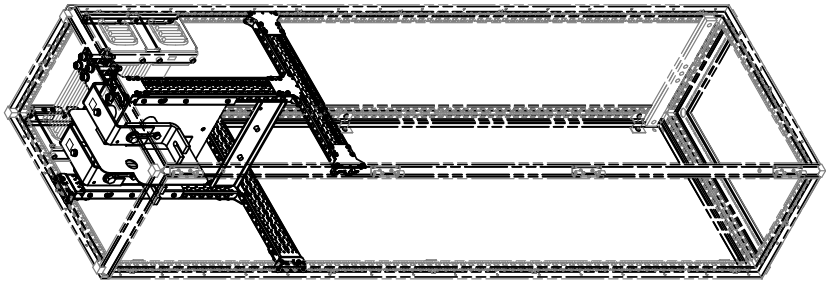
1	2	3	4	5	6	7	8
<p>3AXD50000342594 ASSEMBLY DRAWING 02-Apr-19</p> <p style="font-size: small;">We reserve all rights in this document and in the information contained herein. Reproduction, use or disclosure of this document without express written authority is strictly forbidden. © ABB CORPORATION AND SELECTED AFFILIATES. CONFIDENTIAL</p> <p>Prepared by: M. Michelsson 02-Apr-19 Checked by: M. Michelsson 02-Apr-19 Drawn by: M. Michelsson 02-Apr-19 Title: ASSEMBLY DRAWING FOR RITTAL VXE5</p>							
<p>Initial Approval: 02-Apr-19 M. Michelsson</p>							
<p>STAGE 2 A: R8i DC BUSBARS W400 AND R8i DC CONNECTION installation for fuse solution.</p> <p>See assembly drawing 3AXD50000345151 and 3AXD50000345915 for details and required additional Rittal and standard parts.</p>							
							
<p>Ordering code: 3AXD50000337415 KIT A-4-8-252-VX</p>				<p>Ordering code: 3AXD50000337446 KIT A-4-8-206-VX</p>			
							
<p>Based on: M. Michelsson 02-Apr-19 Customer: M. Michelsson 02-Apr-19 Cust. Doc. No.: M. Michelsson 02-Apr-19 DNS Number: 3AXD10000303254 Weight: kg</p> <p>Doc. No.: 3AXD50000342594 Title: ASSEMBLY DRAWING Part No.: 3AXD50000342594</p> <p>Scale: 1:1 Form: A3 Sheet: 1 of 1 Total: 1</p>							



Stage 2 B: Installation of DC busbars (1) (with DC switch/charging)

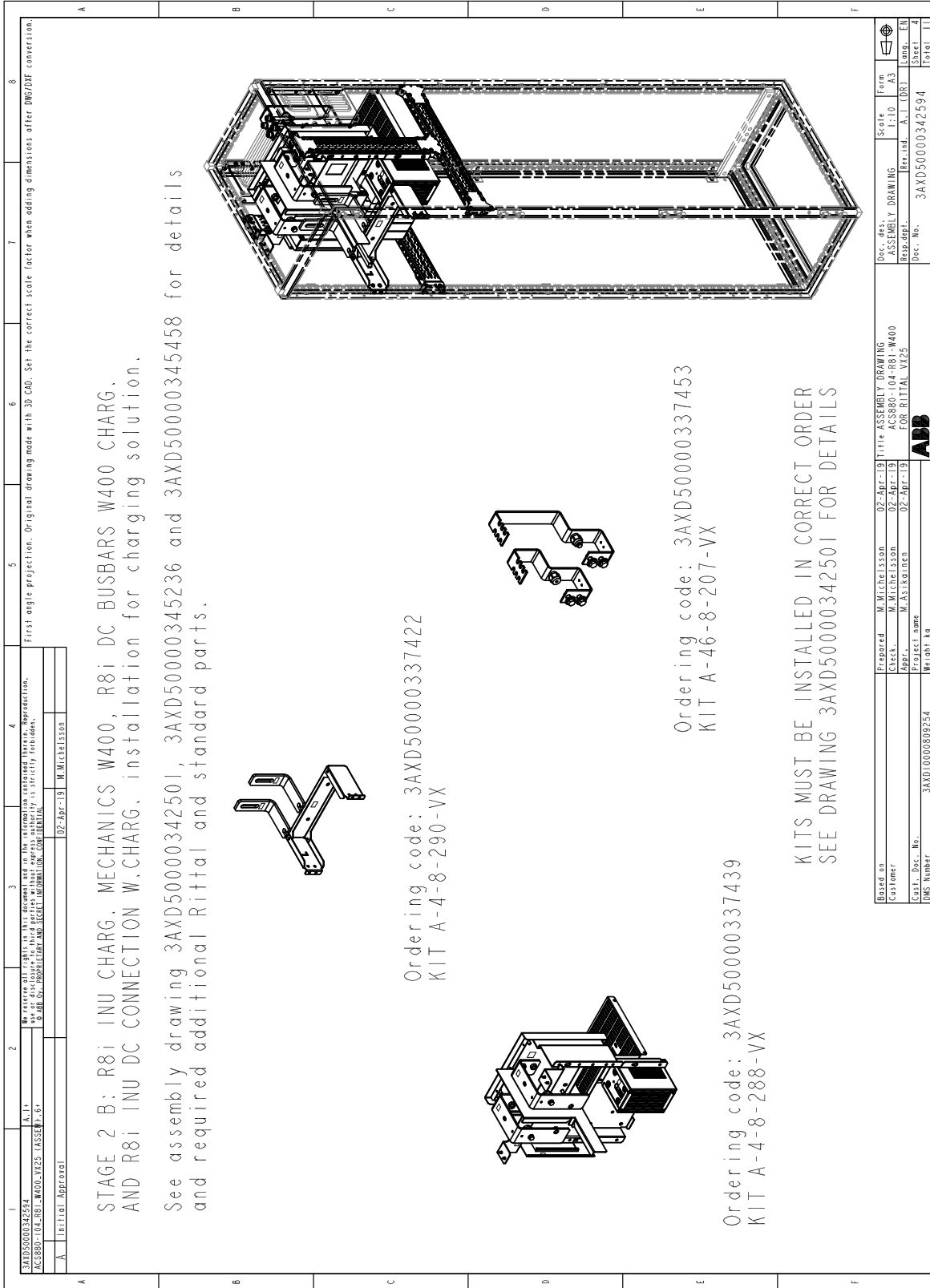

3AXD50000342594
 ACS880-104-R81-W400-VZ25 (ASSEMBLY)
 A.1.1
 M. Michéllsson
 02-Apr-19

STAGE 2 B: R8i INU CHARG. MECHANICS W400, R8i DC BUSBARS W400 CHARG. AND R8i INU DC CONNECTION W.CHARG. installation for charging solution.

See assembly drawing 3AXD50000342501, 3AXD50000345236 and 3AXD50000345458 for details and required additional Rittal and standard parts.

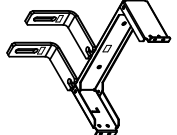

Ordering code: 3AXD50000337422
 KIT A-4-8-290-VX

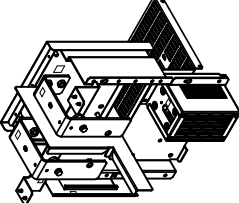

Ordering code: 3AXD50000337439
 KIT A-4-8-288-VX





Ordering code: 3AXD50000337453
 KIT A-4-8-207-VX

KITS MUST BE INSTALLED IN CORRECT ORDER
 SEE DRAWING 3AXD50000342501 FOR DETAILS

Based on	M. Michéllsson	02-Apr-19	Title	ASSEMBLY DRAWING	Scale	Form
Customer	M. Michéllsson	02-Apr-19	ACS880-104-R81-W400	FOR RITTAL VZ25	1:10	A3
Drawn	M. Asikainen	02-Apr-19	FOR RITTAL VZ25			
Project name	3AXD50000342594					
Weight kg	ABB					
Doc. No.	3AXD50000342594					
Sheet	4					
Total	11					

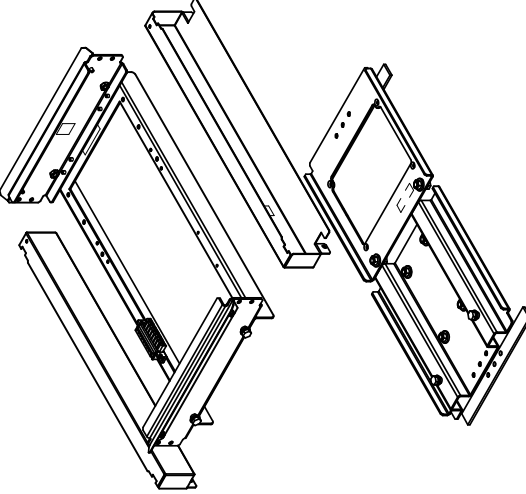
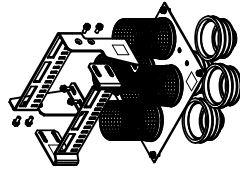
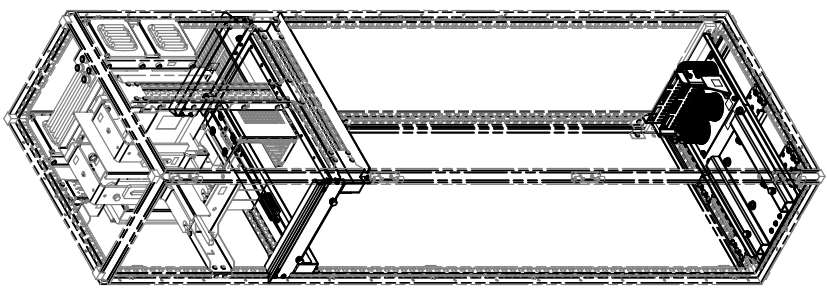
Stage 3: Installation of module installation parts and lead-throughs

1	2	3	4	5	6	7	8
3AXD50000342594 ACS880-04-881-W400-V025-ASSEMBLY Title: Initial Approval Prepared by: M. Michelsson Date: 02-Apr-19 M. Michelsson							
We reserve all rights in this document and in the information contained herein. Reproduction, use or disclosure of this document without express written authority is strictly forbidden. © ABB. ALL RIGHTS RESERVED. CONFIDENTIAL							
<p>STAGE 3: R8i MODULE INSTALLATION PARTS W400 and LEAD-THROUGH FOR BOTTOM PLATE installation</p> <p>See assembly drawing 3AXD50000335152 and 3AXD5000004817 for details and required additional Rittal and standard parts.</p>							
							
<p>Ordering code: 3AXD50000337071 KIT A-4-8-310-VX</p>				<p>Ordering code: 3AXD5000004385 KIT A-468-8-441</p>			
							
First angle projection. Original drawing made with 3D CAD. Set the correct scale factor when adding dimensions after DWG/DXF conversion.							
Based on: M. Michelsson 02-Apr-19 Title: ASSEMBLY DRAWING Checked: M. Michelsson 02-Apr-19 M400 Drawn: M. Michelsson 02-Apr-19 FOR RITTAL V025 Cust. Doc. No. 3AXD10000303254 Weight: kg							
Doc. No. 3AXD50000342594 ASSEMBLY DRAWING Rev. No. 01 Date: 02-Apr-19 Drawn by: M. Michelsson Checked by: M. Michelsson Scale: 1:1 Form: 1							
							



Stage 4 A: Installation of quick connector and output (AC) busbars (cable connection)

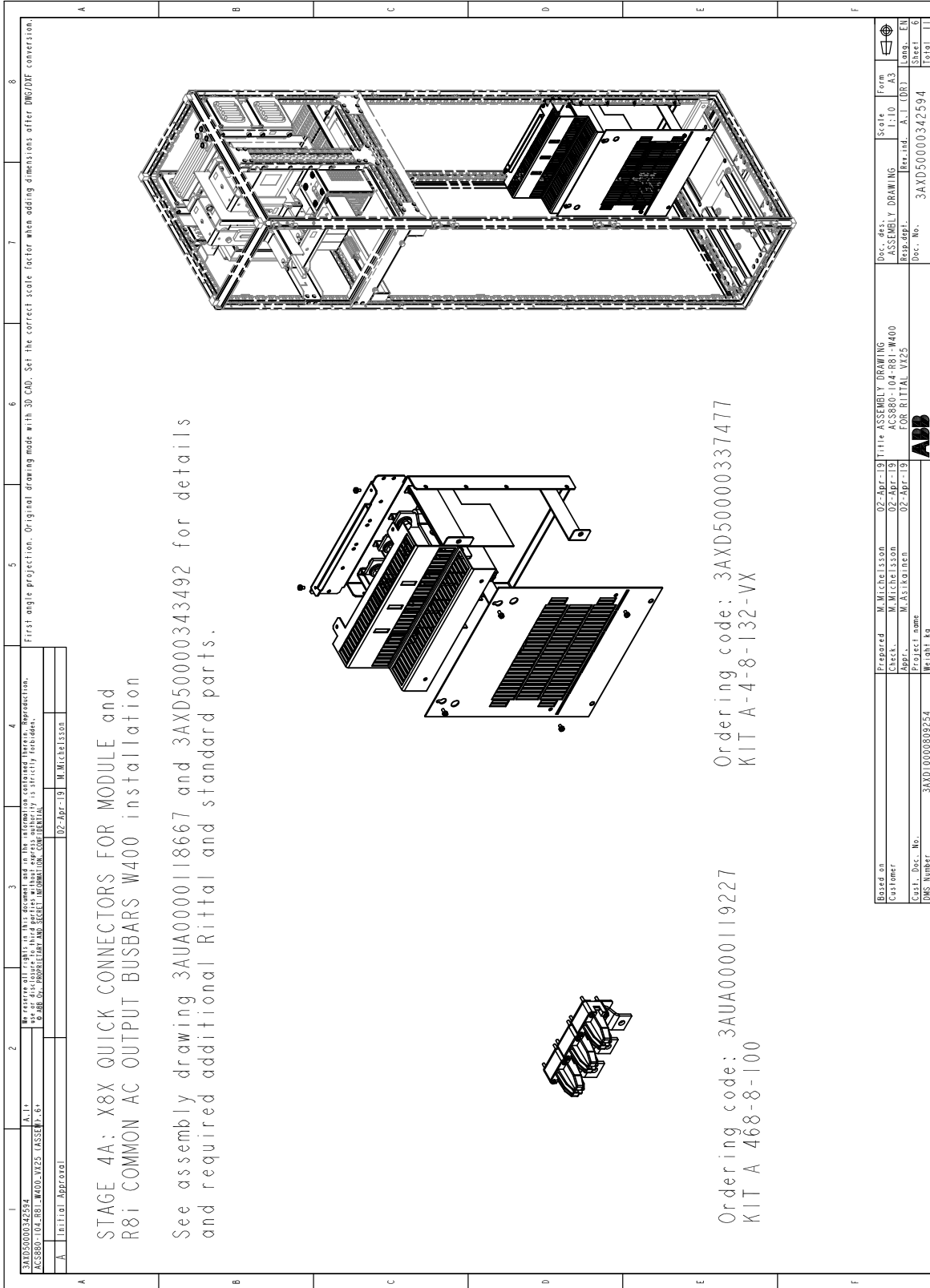

First angle projection. Original drawing made with 3D CAD. Set the correct scale factor when adding dimensions after DWG/DXF conversion.

STAGE 4A: X8X QUICK CONNECTORS FOR MODULE and R8i COMMON AC OUTPUT BUSBARS W400 installation

See assembly drawing 3AUA0000118667 and 3AXD50000343492 for details and required additional Rittal and standard parts.



Ordering code: 3AUA0000119227
KIT A 468-8-100

Ordering code: 3AXD50000337477
KIT A-4-8-132-VX

3AXD50000342594	AC5880-104-R8i-W400-VZ25 (ASSEMBLY)	02-Apr-19	M. Michelsson	02-Apr-19	M. Michelsson	02-Apr-19	ASSEMBLY DRAWING	Scale	Form
A	Initial Approval						FOR RITTAL VZ25	1:10	A3
Prepared		M. Michelsson		02-Apr-19		Title		ASSEMBLY DRAWING	
Check		M. Michelsson		02-Apr-19		Title		AC5880-104-R8i-W400	
Appr.		M. Asikainen		02-Apr-19		Title		FOR RITTAL VZ25	
Project name		3AXD50000342594		Weight kg		Doc. No.		3AXD50000342594	
DMS Number		3AXD50000342594		Weight kg		Doc. No.		3AXD50000342594	
						Rev. ind.		A.1 (DEF)	
						Lang.		EN	
						Sheet		6	
						Total		11	

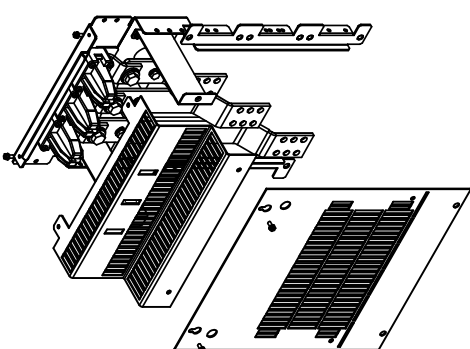
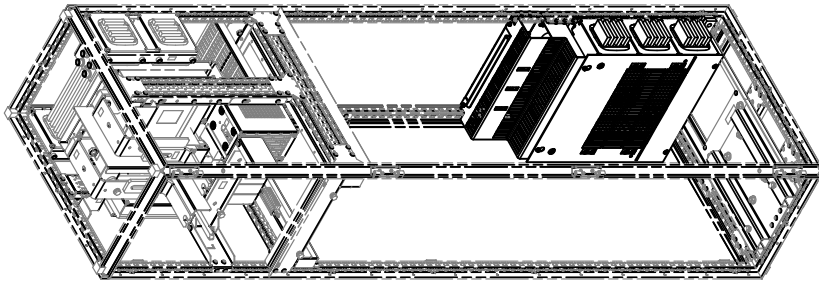

Stage 4 B: Installation of quick connector and output (AC) busbars (common AC output busbar connection)

1	2	3	4	5	6	7	8
3AXD5000342594 3AXS001024081-W400-VX25-ASSEMBLY-6+ M. Michelsson 02-Apr-19 M. Michelsson							
No changes are to be made in this document and in the information contained therein. Reproduction, use or disclosure of this document without explicit authorisation is strictly forbidden. © ABB Oy. INFORMATION FOR SUPPLIER: INFORMATION CONFIDENTIAL							
Initial Approval							
<p>STAGE 4B: R8i COMMON AC OUTPUT BUSBARS W400 and R8i AC BUSBARS W400 installation</p> <p>See assembly drawing 3AUA0000118667 and 3AXD50000343928 for details and required additional Rittal and standard parts.</p>							
							
<p>Ordering code: 3AUA0000119227 KIT A 468-8-100</p>							
							
<p>Ordering code: 3AXD50000337088 KIT A-4-8-140-VX</p>							
							
Prepared M. Michelsson 02-Apr-19 Title ASSEMBLY DRAWING Scale Form Checked M. Michelsson 02-Apr-19 3AXD50000337088 L10 A3 Drawn M. Asplundh 02-Apr-19 FOR RITTAL YX25 FOR RITTAL YX25 Exp. date: R-L D07 Doc. No. 3AXD50000342594 Doc. No. 3AXD50000342594 Part name: Part name: Sheet 1 W: 191 kg Total 11							



Stage 5 A: Installation of DC busbars (2) (without DC switch/charging)

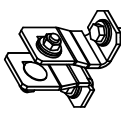
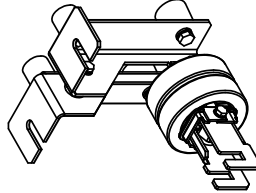
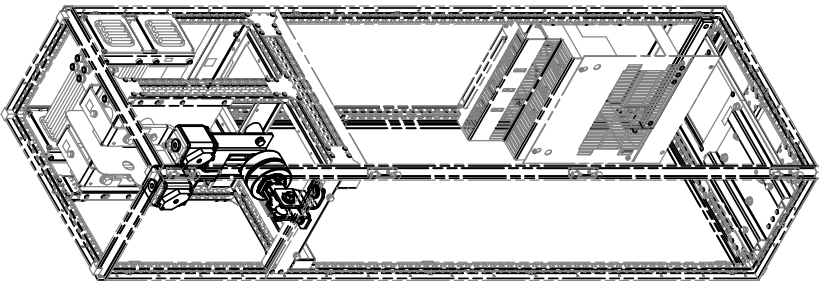

1	2	3	4	5	6	7	8
3AXD50000342594 ACS880-104-R81-W400-VZ25 (ASSEMBLY) - 6" A.I.T. No reserved rights in this document and in the information contained herein. Reproduction, distribution, or use of any part of this document is strictly forbidden. © ABB - 2019. PROHIBITION AND STRICT INFORMATION CONFIDENTIALITY. Prepared: M. Michelsson 02-Apr-19 M. Michelsson Checked: M. Michelsson 02-Apr-19 M. Michelsson Approved: M. Asikainen 02-Apr-19 M. Asikainen Project name: 3AXD1000092524 Weight kg							
STAGE 5A : R81 COMMON MODE BUSBARS and R81 DC FLANGES installation for fuse solution. See assembly drawings 3AXD5000028384 and 3AXD5000028418 for details and required additional Rittal and standard parts.							
 							
Ordering code: 3AXD5000028403 1 kit/module KIT A-468-8-246							
Ordering code: 3AXD5000028401 Toroids/fuses not included in kit 1 kit/module KIT A-468-8-235							
							
Dec. des.: ASSEMBLY DRAWING Resp. des.: A.I.T.DEP. Dec. No.: 3AXD50000342594 Scale: 1:10 Form: A3 Long.: EN Sheet: 8 Total: 11							

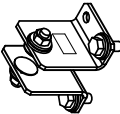
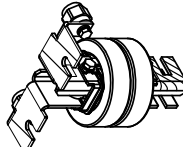
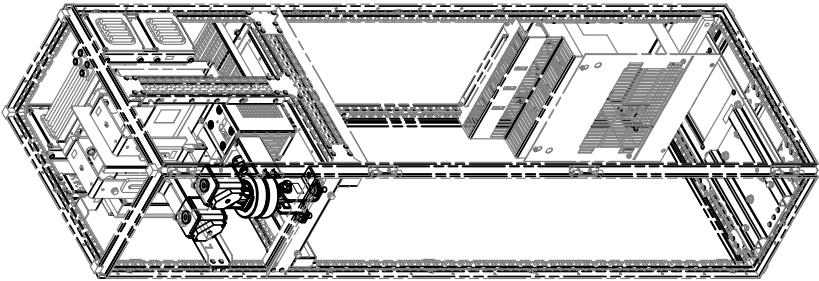

Stage 5 B: Installation of DC busbars (2) (with DC switch/charging)

1	2	3	4	5	6	7	8
<p>3AXD5000034254 ASSEMBLY DRAWING</p> <p>WE EXERCISE ALL RIGHTS IN THIS DOCUMENT AND IN THE INFORMATION CONTAINED HEREIN. REPRODUCTION, USE OR DISCLOSURE OF THIS DOCUMENT OR ANY PART THEREOF WITHOUT EXPRESS WRITTEN PERMISSION IS STRICTLY FORBIDDEN. © ABB CORPORATION AND SELECTED AFFILIATES. CONFIDENTIAL</p> <p>02-Apr-19 M. Michelsson</p> <p>Initial Approval</p>							
<p>STAGE 5B : R8I COMMON MODE BUSBARS CHARG. and R8I DC FLANGES CHARG. installation for charging solution.</p> <p>See assembly drawings 3AXD50000043411 and 3AXD50000043466 for details and required additional Rittal and standard parts.</p>							
							
<p>Ordering code: 3AXD50000044553 1 kit/module KIT A-468-8-248</p>				<p>Ordering code: 3AXD50000044551 Toroids/fuses not included in kit 1 kit/module KIT A-468-8-247</p>			
							
<p>Doc. No. 3AXD5000034254</p> <p>Doc. Title ASSEMBLY DRAWING</p> <p>Rev. No. 04</p> <p>Rev. Date 02-Apr-19</p> <p>Rev. Desc. FOR RITTAL VPE2</p> <p>Doc. No. 3AXD5000034254</p> <p>Rev. No. 04</p> <p>Rev. Date 02-Apr-19</p> <p>Rev. Desc. FOR RITTAL VPE2</p> <p>Doc. No. 3AXD5000034254</p> <p>Rev. No. 04</p> <p>Rev. Date 02-Apr-19</p> <p>Rev. Desc. FOR RITTAL VPE2</p>							



Stage 6: Installation of shrouding

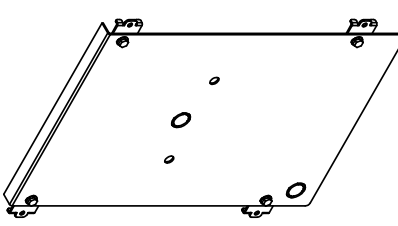
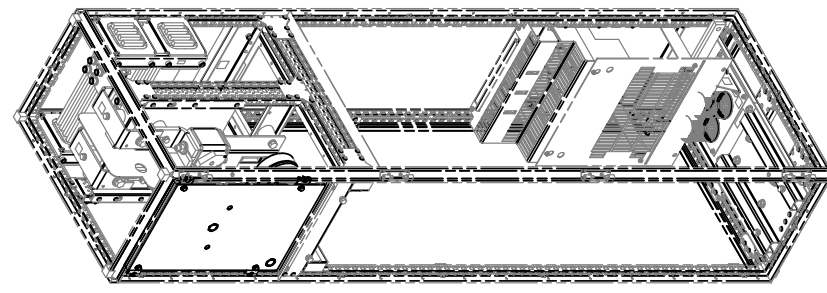

1	2	3	4	5	6	7	8																																																																										
3AXD50000342594 ACS880-104-R81-W400-VZ25 (ASSEMBLY) A.I.T. No reservation rights in this document and in the information contained herein. Reproduction, modification, distribution, or disclosure of this information is strictly prohibited. © ABB. All rights reserved.																																																																																	
A		Initial Approval		02-Apr-19		M. Michelsson																																																																											
<p>STAGE 6: R81 SHROUD INST. PARTS W400 installation</p> <p>See assembly drawing 3AXD50000335169 for details and required additional Rittal and standard parts.</p>																																																																																	
																																																																																	
<p>Ordering code: 3AXD50000337484 KIT A-4-8-359-VX</p>																																																																																	
<table border="1" style="width: 100%; border-collapse: collapse;"> <tr> <td style="width: 15%;">Based on</td> <td style="width: 15%;">M. Michelsson</td> <td style="width: 15%;">02-Apr-19</td> <td style="width: 15%;">Title</td> <td style="width: 15%;">ASSEMBLY DRAWING</td> <td style="width: 10%;">Scale</td> <td style="width: 10%;">Form</td> </tr> <tr> <td>Customer</td> <td>M. Michelsson</td> <td>02-Apr-19</td> <td>ACS880-104-R81-W400</td> <td>FOR RITTAL VZ25</td> <td>1:10</td> <td>A3</td> </tr> <tr> <td>Appr.</td> <td>M. Asikainen</td> <td>02-Apr-19</td> <td></td> <td></td> <td></td> <td></td> </tr> <tr> <td>Project name</td> <td colspan="6"></td> </tr> <tr> <td>DWG. Number</td> <td>3AXD50000342594</td> <td colspan="5"></td> </tr> <tr> <td>Weight kg</td> <td colspan="6"></td> </tr> <tr> <td colspan="4"></td> <td colspan="2"> Dec. des. ASSEMBLY DRAWING </td> <td colspan="2"> Scale 1:10 </td> </tr> <tr> <td colspan="4"></td> <td colspan="2"> Resp. des. A.I.T. (DR) </td> <td colspan="2"> Form A3 </td> </tr> <tr> <td colspan="4"></td> <td colspan="2"> Dec. No. 3AXD50000342594 </td> <td colspan="2"> Long. EN Sheet 10 </td> </tr> <tr> <td colspan="4"></td> <td colspan="2"></td> <td colspan="2"> Total 11 </td> </tr> </table>								Based on	M. Michelsson	02-Apr-19	Title	ASSEMBLY DRAWING	Scale	Form	Customer	M. Michelsson	02-Apr-19	ACS880-104-R81-W400	FOR RITTAL VZ25	1:10	A3	Appr.	M. Asikainen	02-Apr-19					Project name							DWG. Number	3AXD50000342594						Weight kg											Dec. des. ASSEMBLY DRAWING		Scale 1:10						Resp. des. A.I.T. (DR)		Form A3						Dec. No. 3AXD50000342594		Long. EN Sheet 10								Total 11	
Based on	M. Michelsson	02-Apr-19	Title	ASSEMBLY DRAWING	Scale	Form																																																																											
Customer	M. Michelsson	02-Apr-19	ACS880-104-R81-W400	FOR RITTAL VZ25	1:10	A3																																																																											
Appr.	M. Asikainen	02-Apr-19																																																																															
Project name																																																																																	
DWG. Number	3AXD50000342594																																																																																
Weight kg																																																																																	
				Dec. des. ASSEMBLY DRAWING		Scale 1:10																																																																											
				Resp. des. A.I.T. (DR)		Form A3																																																																											
				Dec. No. 3AXD50000342594		Long. EN Sheet 10																																																																											
						Total 11																																																																											

Stage 7: Installation of inverter module

1	2	3	4	5	6	7	8																																																						
<p>STAGE 7: MODULE INSTALLATION</p> <p>See ACS880-104 Hardware Manual for details</p>																																																													
<p>3AXD5000342594 ACS880-104-187L-W400-V025-ASSEMBLY</p> <p>1:1 A Initial Approval</p> <p>Prepared by: M. Michelsson Checked by: M. Michelsson Approved by: M. Michelsson Date: 02-Apr-19</p> <p>Original drawing made with 3D CAD. Set the correct scale factor when adding dimensions after DWG/DWG conversion.</p>																																																													
<table border="1" style="width: 100%; border-collapse: collapse;"> <tr> <td>Based on:</td> <td>M. Michelsson</td> <td>02-Apr-19</td> <td>Title ASSEMBLY DRAWING</td> <td>Doc. No.</td> <td>3AXD5000342594</td> </tr> <tr> <td>Customer:</td> <td>M. Michelsson</td> <td>02-Apr-19</td> <td>404 M400</td> <td>Scale:</td> <td>1:1</td> </tr> <tr> <td>Drawn by:</td> <td>M. Michelsson</td> <td>02-Apr-19</td> <td>FOR RITUAL V025</td> <td>Form:</td> <td>1.0</td> </tr> <tr> <td>Customer No.:</td> <td>3AXD10000809254</td> <td></td> <td></td> <td>Rev. no.:</td> <td>001</td> </tr> <tr> <td>DWG. Number:</td> <td>3AXD10000809254</td> <td></td> <td></td> <td>Drawn by:</td> <td>EN</td> </tr> <tr> <td></td> <td></td> <td></td> <td></td> <td>Checked by:</td> <td>EN</td> </tr> <tr> <td></td> <td></td> <td></td> <td></td> <td>Approved by:</td> <td>EN</td> </tr> <tr> <td></td> <td></td> <td></td> <td></td> <td>Doc. No.:</td> <td>3AXD5000342594</td> </tr> <tr> <td></td> <td></td> <td></td> <td></td> <td>Weight:</td> <td>kg</td> </tr> </table>								Based on:	M. Michelsson	02-Apr-19	Title ASSEMBLY DRAWING	Doc. No.	3AXD5000342594	Customer:	M. Michelsson	02-Apr-19	404 M400	Scale:	1:1	Drawn by:	M. Michelsson	02-Apr-19	FOR RITUAL V025	Form:	1.0	Customer No.:	3AXD10000809254			Rev. no.:	001	DWG. Number:	3AXD10000809254			Drawn by:	EN					Checked by:	EN					Approved by:	EN					Doc. No.:	3AXD5000342594					Weight:	kg
Based on:	M. Michelsson	02-Apr-19	Title ASSEMBLY DRAWING	Doc. No.	3AXD5000342594																																																								
Customer:	M. Michelsson	02-Apr-19	404 M400	Scale:	1:1																																																								
Drawn by:	M. Michelsson	02-Apr-19	FOR RITUAL V025	Form:	1.0																																																								
Customer No.:	3AXD10000809254			Rev. no.:	001																																																								
DWG. Number:	3AXD10000809254			Drawn by:	EN																																																								
				Checked by:	EN																																																								
				Approved by:	EN																																																								
				Doc. No.:	3AXD5000342594																																																								
				Weight:	kg																																																								



■ Two R8i modules in a 600 mm wide Rittal VX25 enclosure

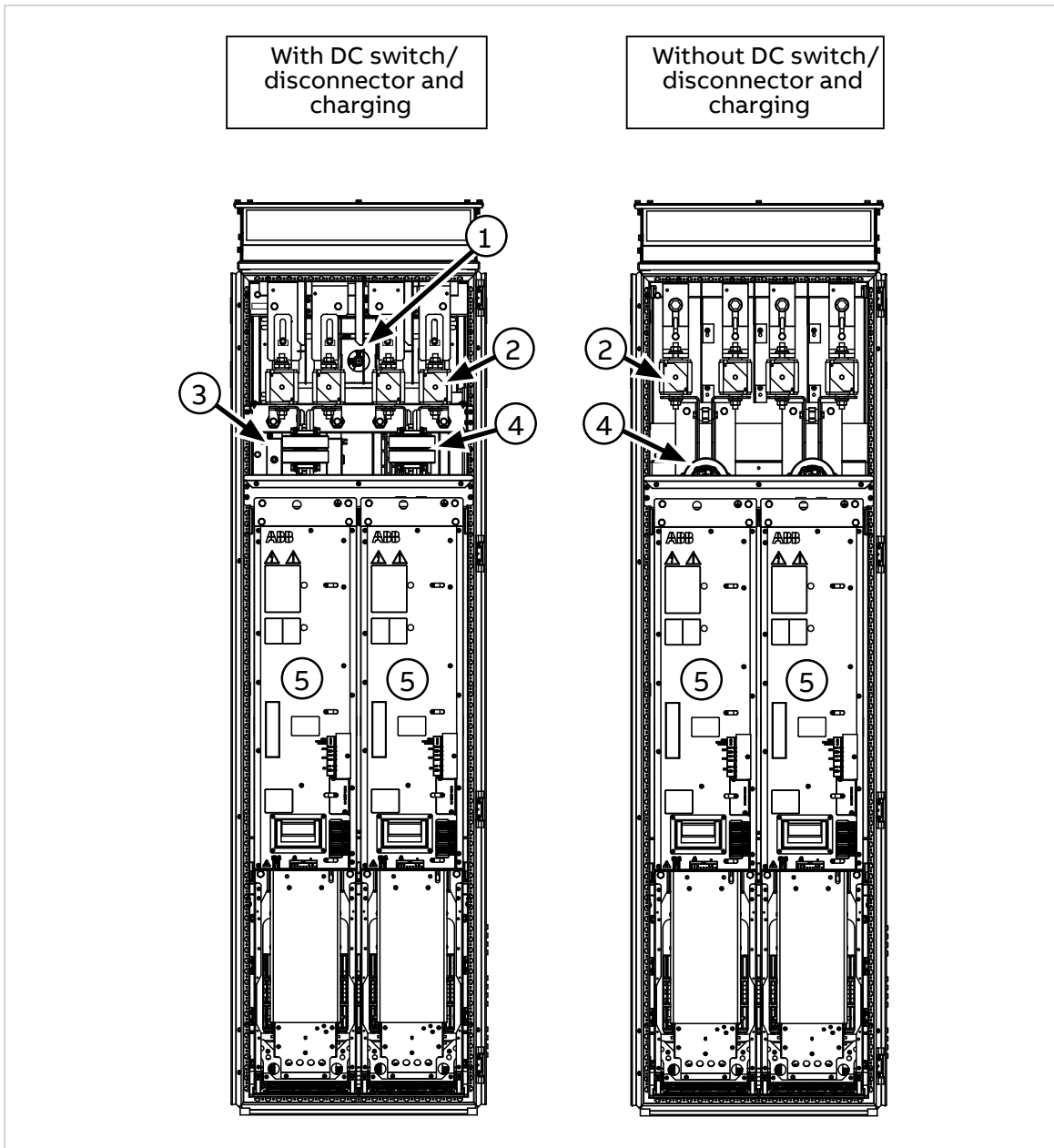

Description

Cubicle including:

1. DC switch/disconnector (obscured)
2. DC fuses
3. Charging switch
4. Common mode filters
5. Inverter module

Installation stages

#	Installation stage	Instruction code	Kit code	Kit ordering code
1	Common parts:			
	Baying parts	3AXD50000336340	-	-
	PE busbar	3AXD50000336104	-	-
	Divider panel	3AXD50000336692	-	-
	DC busbars	3AXD50000333639	A-468-X-001-VX	3AXD50000333387
2 A	DC connection 1 of 2 (from DC bus to DC fuses) without DC switch/charging:			
	Busbar assembly	3AXD50000342471	A-6-8-255-VX	3AXD50000337521
	Busbars	3AXD50000345915	A-46-8-206-VX	3AXD50000337446
2 B	DC connection 1 of 2 (from DC bus to DC fuses) with DC switch/charging:			
	DC switch/charging assembly	3AXD50000342860	A-6-8-289-VX	3AXD50000337545
	Busbar assembly	3AXD50000342983	A-6-8-291-VX	3AXD50000337538
	Busbars	3AXD50000345458	A-46-8-207-VX	3AXD50000337453
3	Module mechanical installation parts, lead-throughs:			
	Module top/bottom guides	3AXD50000345052	A-6-8-309-VX	3AXD50000337514
	Lead-throughs	3AXD50000004817	A-468-8-441	3AXD50000004385
4 A	Quick connector, output (AC) busbars (cable connection without bridging):			
	Quick connector	3AUA0000118667	A-468-8-100	3AUA0000119227
	Busbars and shrouds	3AXD50000345526	A-6-8-133-VX	3AXD50000337569
4 B	Quick connector, output (AC) busbars (cable connection with bridging):			
	Quick connector	3AUA0000118667	A-468-8-100	3AUA0000119227
	Busbars and shrouds	3AXD50000345632	A-6-8-134-VX	3AXD50000337576
4 C	Quick connector, output (AC) busbars (common AC output busbar connection):			
	Quick connector	3AUA0000118667	A-468-8-100	3AUA0000119227
	Busbars and shrouds	3AXD50000346196	A-6-8-141-VX	3AXD50000337552
5 A	DC connection 2 of 2 (from DC fuses to inverter module) without DC switch/charging:			
	DC connection flanges	3AXD50000028384	A-468-8-246	3AXD50000028403
	DC busbars with common mode filters	3AXD50000028418	A-468-8-235	3AXD50000028401
5 B	DC connection 2 of 2 (from DC fuses to inverter module) with DC switch/charging:			
	DC connection flanges	3AXD50000043466	A-468-8-248	3AXD50000044553



142 Cabinet construction

#	Installation stage	Instruction code	Kit code	Kit ordering code
	DC busbars with common mode filters (filters not included in kit)	3AXD50000043411	A-468-8-247	3AXD50000044551
6	Shrouding	3AXD50000335022	A-6-8-360-VX	3AXD50000337378
7	Inverter module	-	-	-



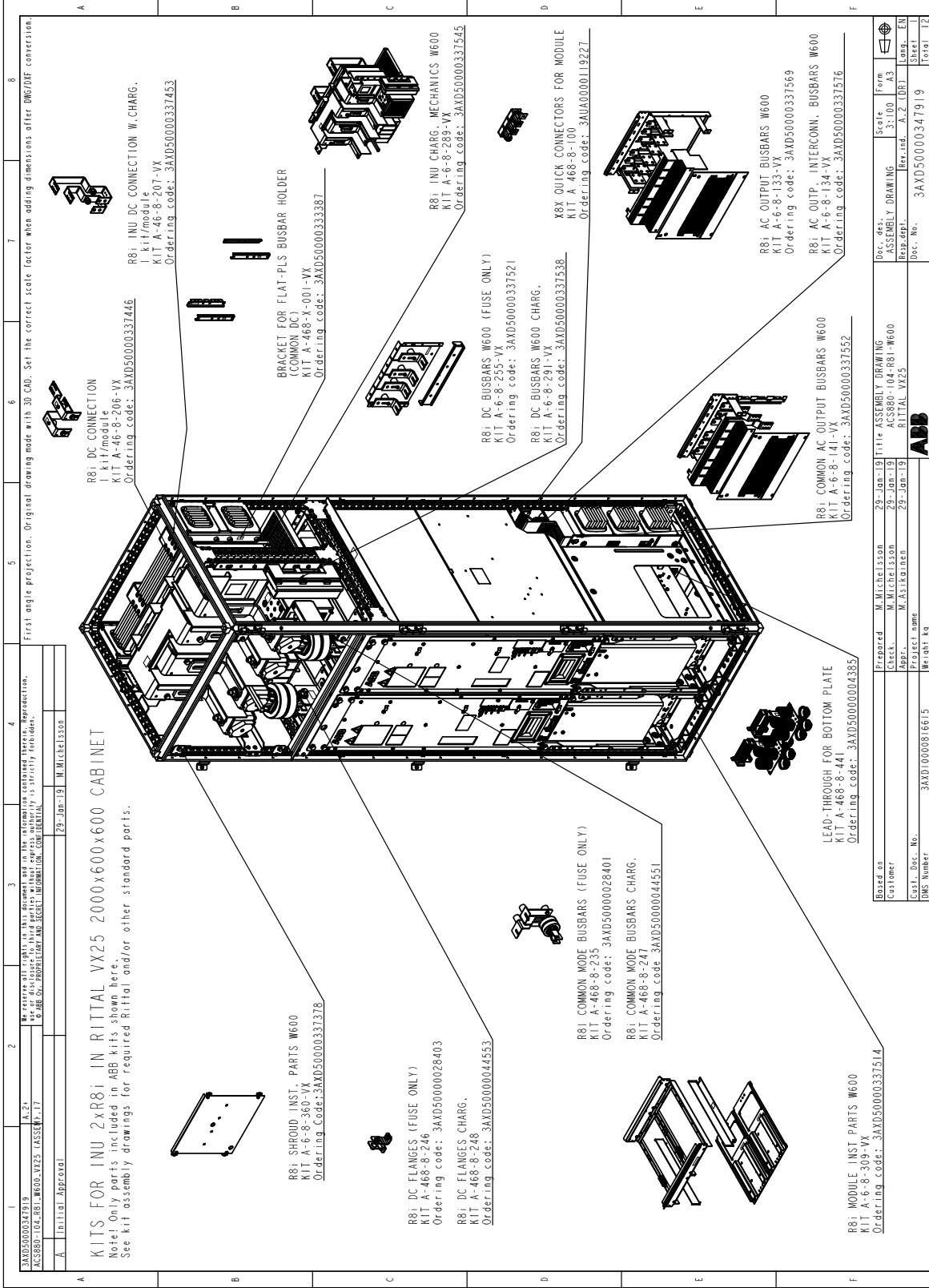

Overview of kits

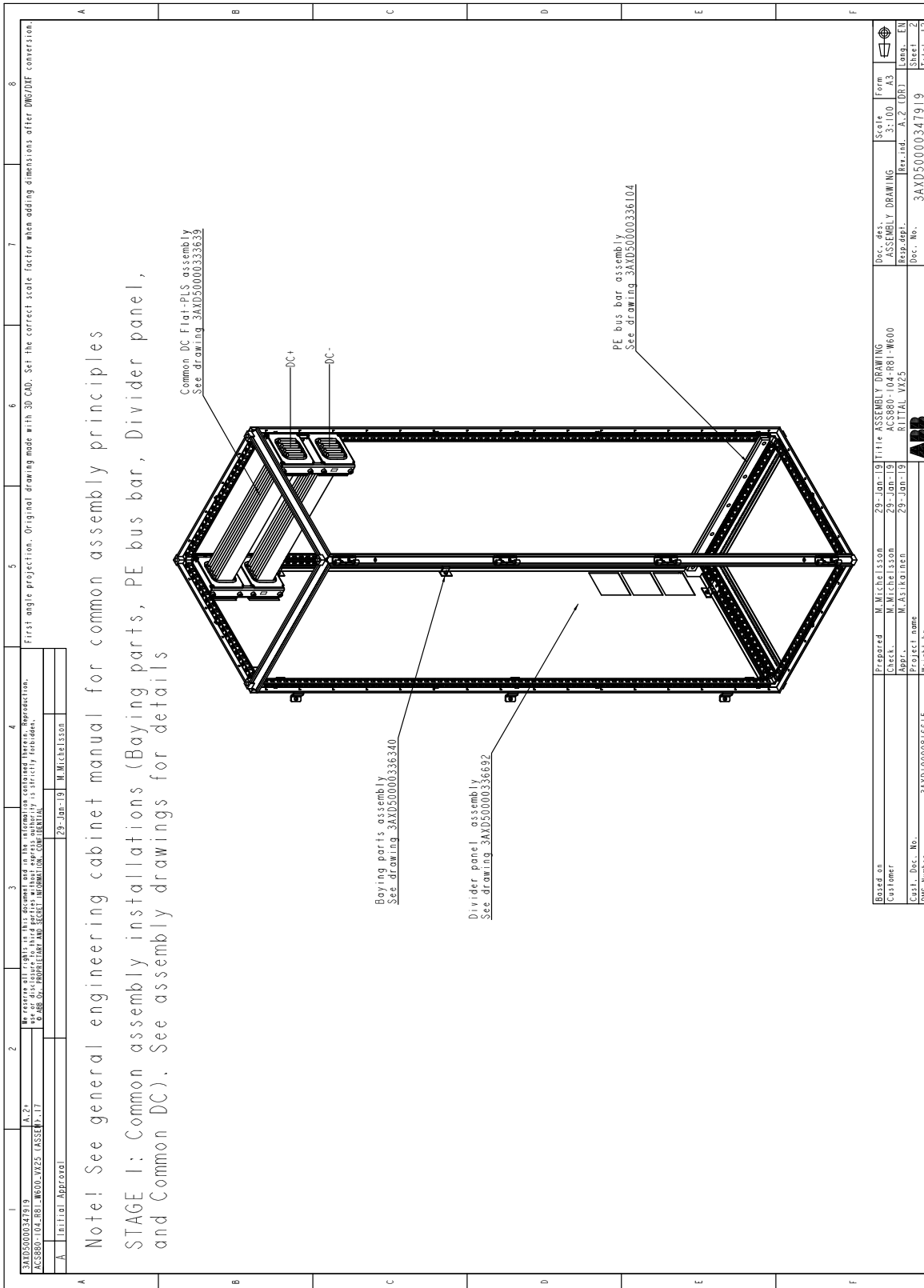

Stage 1: Installation of common parts

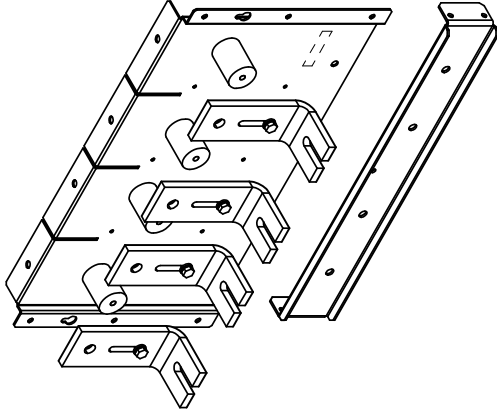
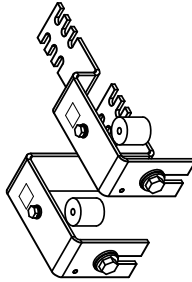
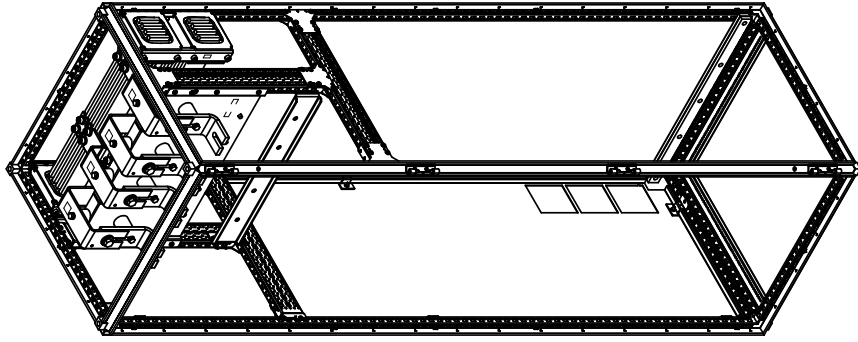

Stage 2 A: Installation of DC busbars (1) (without DC switch/charging)

1	2	3	4	5	6	7	8
3AXD5000034271-19 ACS880-04-181-W600-V22-ASSEMBLY A Initial Approval 29-Jan-19 M. Michelsson							
We reserve all rights in this document and in the information contained herein. Reproduction, use or disclosure of this document without express written authority is strictly forbidden. © ABB CORPORATION AND SELECTED AFFILIATES. CONFIDENTIAL							
First angle projection. Original drawing made with 3D CAD. Set the correct scale factor when adding dimensions after DWG/DXF conversion.							
A	B	C	D	E	F		
<p>STAGE 2 A: R8i DC BUSBARS W600 and R8i DC CONNECTION installation for fuse solution.</p> <p>See assembly drawing 3AXD5000034271 and 3AXD50000345915 for details and required additional Rittal and standard parts.</p>							
							
			<p>Ordering code: 3AXD50000337521 KIT A-6-8-255-VX</p>			<p>Ordering code: 3AXD50000337446 1 kit/module KIT A-46-8-206-VX</p>	
				Prepared M. Michelsson 29-Jan-19 Title ASSEMBLY DRAWING Checked M. Michelsson 29-Jan-19 R8i W600 Drawn M. Michelsson 29-Jan-19 RITTAL V22 Project name 3AXD10000816615 Weight kg DNS Number 3AXD5000034719			
				Doc. No. 3AXD5000034719 Doc. Rev. ASSEMBLY DRAWING Rev. No. 01 Scale 3:100 Form 3 Sheet 1 of 3 Total 3			
							



Stage 2 B: Installation of DC busbars (1) (with DC switch/charging)

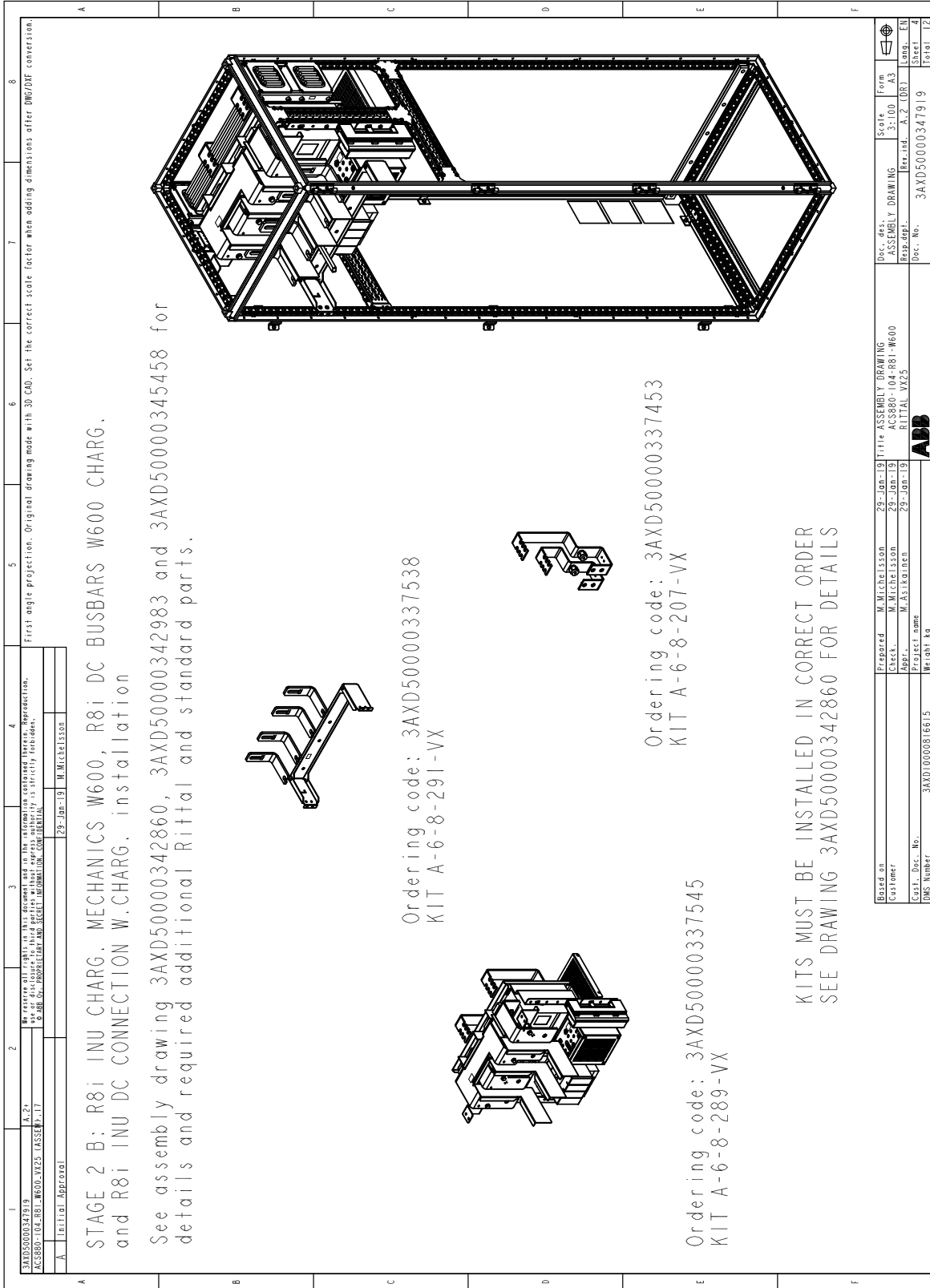

STAGE 2 B: R8i INU CHARG. MECHANICS W600, R8i DC BUSBARS W600 CHARG. and R8i INU DC CONNECTION W.CHARG. installation

See assembly drawing 3AXD50000342860, 3AXD50000342983 and 3AXD50000345458 for details and required additional Rittal and standard parts.

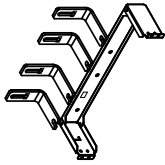

Ordering code: 3AXD50000337538
KIT A-6-8-291-VX

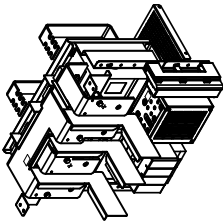

Ordering code: 3AXD50000337545
KIT A-6-8-289-VX



Ordering code: 3AXD50000337453
KIT A-6-8-207-VX

KITS MUST BE INSTALLED IN CORRECT ORDER
SEE DRAWING 3AXD50000342860 FOR DETAILS

3AXD50000347919	AC5880-104-R8i W600-VX25 (ASSEMBLY)	29-Jan-19	M. Michelsson	3AXD50000347919	ASSEMBLY DRAWING	3:100	A3	4
Based on: M. Michelsson 29-Jan-19 Title: ASSEMBLY DRAWING Customer: M. Michelsson 29-Jan-19 ACS880-104-R8i W600 Checked: M. Michelsson 29-Jan-19 RITTAL VX25 Approved: M. Asikainen 29-Jan-19 Project name: 3AXD50000347919 Project no.: 3AXD50000347919 Weight kg:				Dec. des.: ASSEMBLY DRAWING Resp. dept.: Dec. No.: 3AXD50000347919 Scale: 3:100 Form: A3 Rev. ind.: A.2 (DB) Lang.: EN Sheet: 4 Total: 12				

Stage 4 A: Installation of quick connector and output (AC) busbars (cable connection)

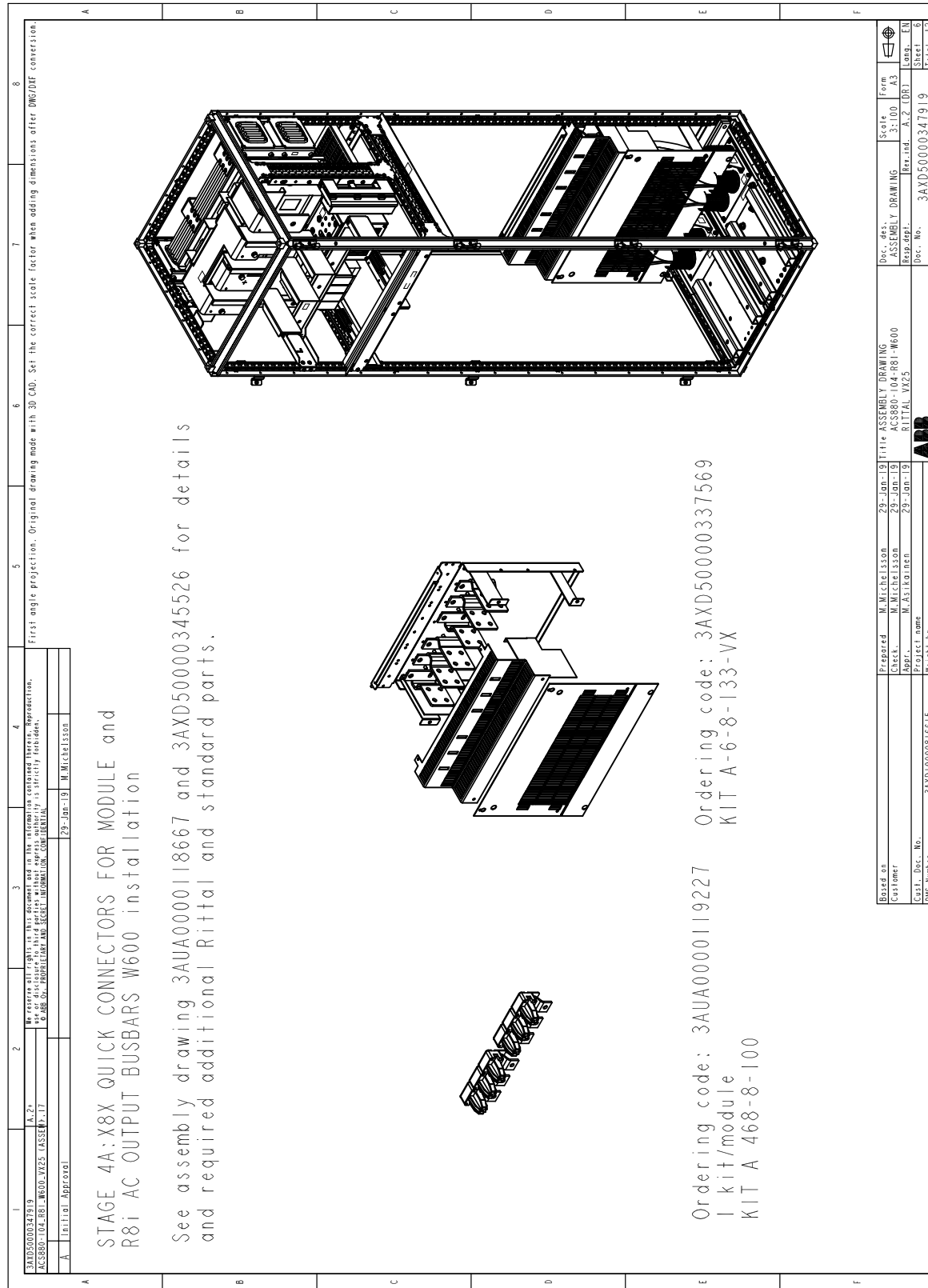

Stage 4 B: Installation of quick connector and output (AC) busbars (cable connection with bridging)

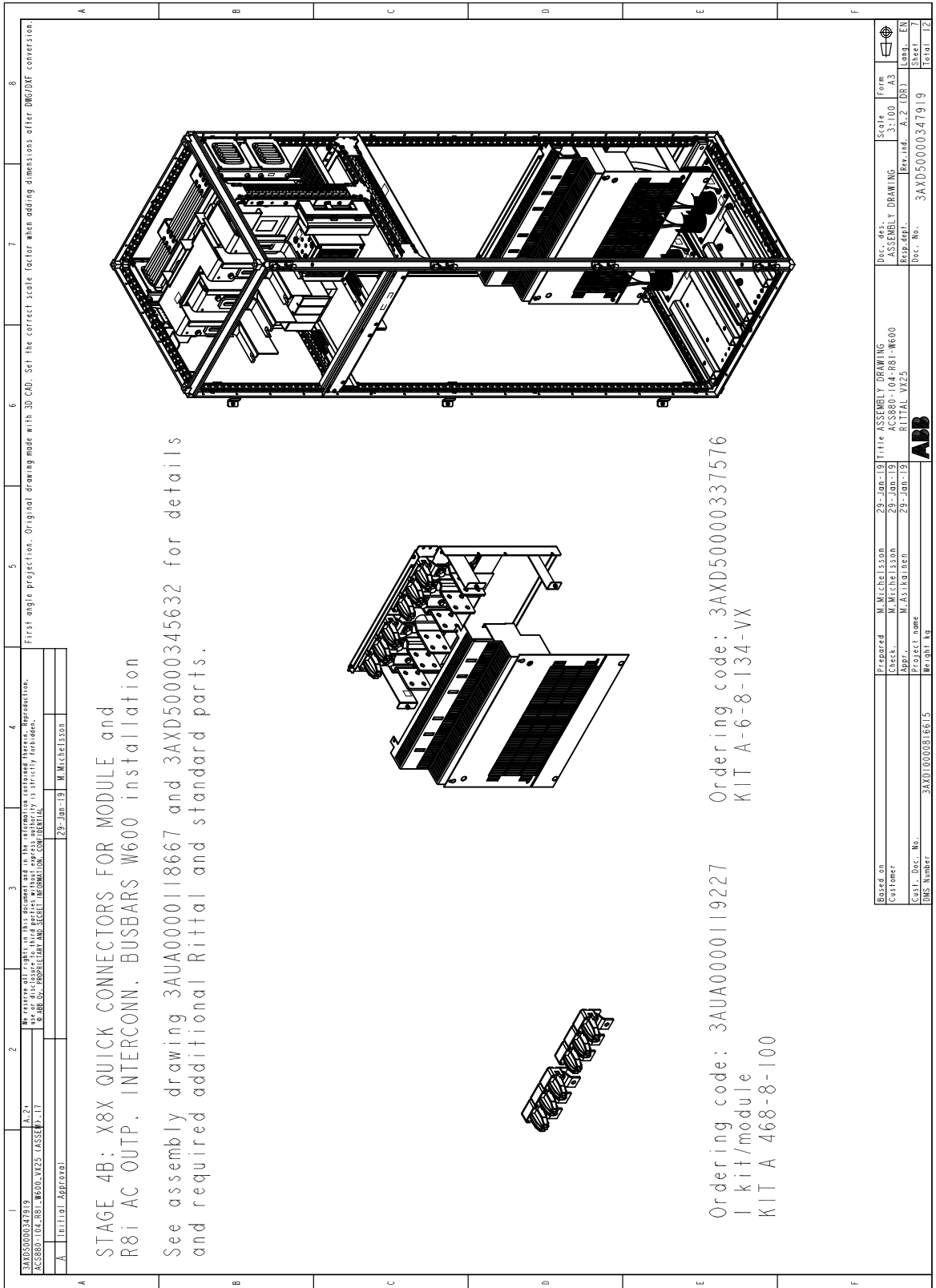

Stage 4 C: Installation of quick connector and output (AC) busbars (common AC output busbar connection)

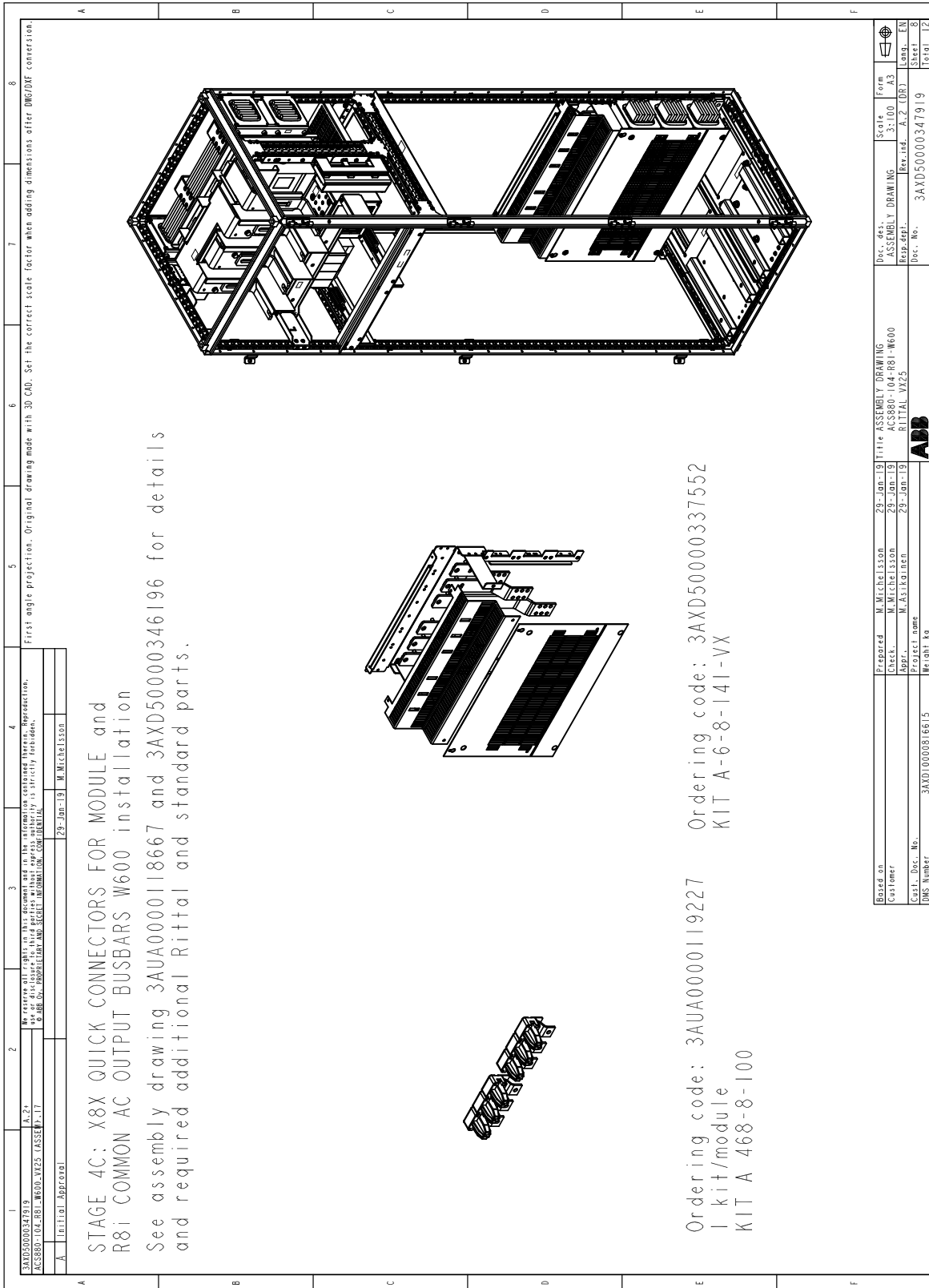

First angle projection. Original drawing made with 3D CAD. Set the correct scale factor when adding dimensions after DWG/DXF conversion.

3AXD50000347919	A.2.1	Prepared	M. Michelsson	29-Jan-19	M. Michelsson
ACS880-104-R81-W600-VZ5-ASSEMBLY-17		Checked	M. Michelsson	29-Jan-19	
		Approved	M. Asikainen	29-Jan-19	
		Project name	RITTAL VVZ5		
		DWG Number	3AXD10000347919		
		Weight	kg		

STAGE 4C: X8X QUICK CONNECTORS FOR MODULE and R8i COMMON AC OUTPUT BUSBARS W600 installation
 See assembly drawing 3AUA0000118667 and 3AXD50000346196 for details and required additional Rittal and standard parts.

Ordering code: 3AUA0000119227
 I kit/module
 KIT A 468-8-100

Ordering code: 3AXD50000337552
 KIT A-6-8-141-VX

Based on	Prepared	M. Michelsson	29-Jan-19	Title	ASSEMBLY DRAWING	Scale	3:100	Form	A3
Customer	Checked	M. Michelsson	29-Jan-19	ACS880-104-R81-W600	RITTAL VVZ5	Rev. ind.	A.2. (DR)	Land	EN
Cust. Doc. No.	Approved	M. Asikainen	29-Jan-19	3AXD50000347919		Doc. No.	3AXD50000347919	Sheet	8
DWG Number								Total	172



Stage 5 A: Installation of DC busbars (2) (without DC switch/charging)

<p>3AXD5000028418 ASSEMBLY DRAWING</p>	<p>1 Initial Approval</p>	<p>2 3 4 5 6 7 8</p>	<p>9 10 11 12</p>	<p>13 14 15 16 17 18 19 20</p>	<p>21 22 23 24 25 26 27 28 29 30 31 32 33 34 35 36 37 38 39 40 41 42 43 44 45 46 47 48 49 50 51 52 53 54 55 56 57 58 59 60 61 62 63 64 65 66 67 68 69 70 71 72 73 74 75 76 77 78 79 80 81 82 83 84 85 86 87 88 89 90 91 92 93 94 95 96 97 98 99 100</p>	<p>101 102 103 104 105 106 107 108 109 110 111 112 113 114 115 116 117 118 119 120 121 122 123 124 125 126 127 128 129 130 131 132 133 134 135 136 137 138 139 140 141 142 143 144 145 146 147 148 149 150 151 152 153 154 155 156 157 158 159 160 161 162 163 164 165 166 167 168 169 170 171 172 173 174 175 176 177 178 179 180 181 182 183 184 185 186 187 188 189 190 191 192 193 194 195 196 197 198 199 200</p>	<p>201 202 203 204 205 206 207 208 209 210 211 212 213 214 215 216 217 218 219 220 221 222 223 224 225 226 227 228 229 230 231 232 233 234 235 236 237 238 239 240 241 242 243 244 245 246 247 248 249 250 251 252 253 254 255 256 257 258 259 260 261 262 263 264 265 266 267 268 269 270 271 272 273 274 275 276 277 278 279 280 281 282 283 284 285 286 287 288 289 290 291 292 293 294 295 296 297 298 299 300</p>	<p>301 302 303 304 305 306 307 308 309 310 311 312 313 314 315 316 317 318 319 320 321 322 323 324 325 326 327 328 329 330 331 332 333 334 335 336 337 338 339 340 341 342 343 344 345 346 347 348 349 350 351 352 353 354 355 356 357 358 359 360 361 362 363 364 365 366 367 368 369 370 371 372 373 374 375 376 377 378 379 380 381 382 383 384 385 386 387 388 389 390 391 392 393 394 395 396 397 398 399 400</p>	<p>401 402 403 404 405 406 407 408 409 410 411 412 413 414 415 416 417 418 419 420 421 422 423 424 425 426 427 428 429 430 431 432 433 434 435 436 437 438 439 440 441 442 443 444 445 446 447 448 449 450 451 452 453 454 455 456 457 458 459 460 461 462 463 464 465 466 467 468 469 470 471 472 473 474 475 476 477 478 479 480 481 482 483 484 485 486 487 488 489 490 491 492 493 494 495 496 497 498 499 500</p>
--	-------------------------------	--	-------------------------------	--	---	--	--	--	--

We reserve all rights in this document and in the information contained herein. Reproduction, use or disclosure without express authority is strictly forbidden.
 © ABB Ltd. 2019. ALL RIGHTS RESERVED. CONFIDENTIAL.

Prepared: M. Michelsson 28-Jan-19 Title: ASSEMBLY DRAWING
 Checked: M. Michelsson 29-Jan-19 Title: ASSEMBLY DRAWING
 Drawn: M. Michelsson 29-Jan-19 Title: R81-R600
 Part name: KIT A-468-8-235
 Part No.: 3AXD5000028418
 Weight: kg

Based on: M. Michelsson 28-Jan-19 Title: ASSEMBLY DRAWING
 Customer: M. Michelsson 29-Jan-19 Title: R81-R600
 Cust. Doc. No.: M. Michelsson 29-Jan-19 Title: RITTAL V623
 Part No.: 3AXD500003419
 Weight: kg

Doc. No.: 3AXD500003419
 Rev. No.: 1
 Scale: 3:100
 Form: 3

ASSEMBLY DRAWING
 R81 DC FLANGES installation for fuse solution

STAGE 5A : R81 COMMON MODE BUSBARS and
 R81 DC FLANGES installation for fuse solution

See assembly drawings 3AXD5000028384 and 3AXD5000028418 for details
 and required additional Rittal and standard parts.



Ordering code: 3AXD5000028403
 1 kit/module
 KIT A-468-8-246
 Toroids/fuses not included in kit



Ordering code: 3AXD5000028401
 1 kit/module
 KIT A-468-8-235
 Toroids/fuses not included in kit

First angle projection. Original drawing made with 3D CAD. Set the correct scale factor when adding dimensions after DWG/DXF conversion.



Stage 5 B: Installation of DC busbars (2) (with DC switch/charging)

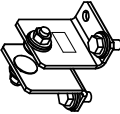
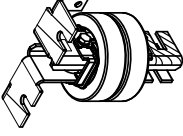
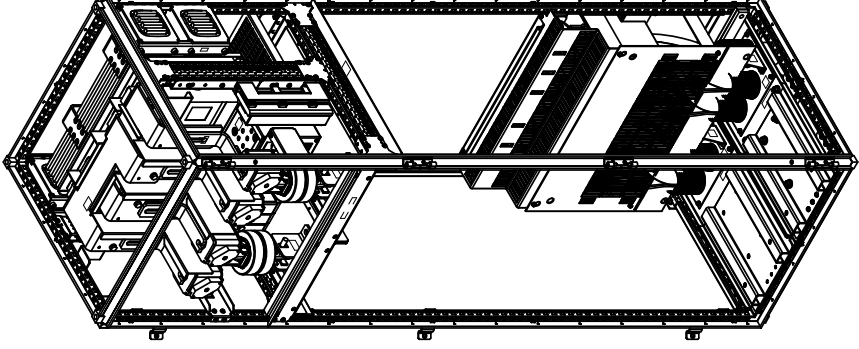

1	2	3	4	5	6	7	8																																																																						
3AXD50000044519 ACS880-104-R81-W600-VX25 (ASSEMBLY) 17 A Initial Approval 29-Jan-19 M. Michelsson																																																																													
We reserve all rights for this document and in the information contained herein. Reproduction, storage in retrieval systems, copying, distribution, or any other use is strictly forbidden.																																																																													
<p>STAGE 5B : R81 COMMON MODE BUSBARS CHARG. and R8i DC FLANGES CHARG. installation for charging solution</p> <p>See assembly drawings 3AXD50000043411 and 3AXD50000043466 for details and required additional Rittal and standard parts.</p>																																																																													
 																																																																													
<p>Ordering code: 3AXD50000044553 1 kit/module KIT A-468-8-248</p> <p>Ordering code: 3AXD50000044551 Toroids/fuses not included in kit 1 kit/module KIT A-468-8-247</p>																																																																													
																																																																													
<table border="1" style="width: 100%; border-collapse: collapse; font-size: x-small;"> <tr> <td>Based on</td> <td>Prepared</td> <td>M. Michelsson</td> <td>29-Jan-19</td> <td>Title</td> <td>ASSEMBLY DRAWING</td> <td>Scale</td> <td>3:100</td> <td>Form</td> <td>A3</td> </tr> <tr> <td>Customer</td> <td>Check.</td> <td>M. Michelsson</td> <td>29-Jan-19</td> <td>ACS880-104-R81-W600</td> <td></td> <td></td> <td></td> <td></td> <td></td> </tr> <tr> <td></td> <td>Appr.</td> <td>M. Asikainen</td> <td>29-Jan-19</td> <td>RITTAL VX25</td> <td></td> <td></td> <td></td> <td></td> <td></td> </tr> <tr> <td>Cost. No.</td> <td>Project name</td> <td colspan="2"></td> <td colspan="2"></td> <td colspan="2"></td> <td colspan="2"></td> </tr> <tr> <td>DMS Number</td> <td>3AXD10000816615</td> <td colspan="2"></td> <td colspan="2"></td> <td colspan="2"></td> <td colspan="2"></td> </tr> <tr> <td colspan="2"></td> <td colspan="2"></td> <td colspan="2"></td> <td colspan="2"></td> <td colspan="2" style="text-align: center;">ABB</td> </tr> <tr> <td colspan="2"></td> <td colspan="2"></td> <td colspan="2"></td> <td colspan="2"></td> <td colspan="2"> Doc. des. ASSEMBLY DRAWING Resp. dept. A.2 LDBJ Doc. No. 3AXD500000347919 Sheet 10 of 12 </td> </tr> </table>								Based on	Prepared	M. Michelsson	29-Jan-19	Title	ASSEMBLY DRAWING	Scale	3:100	Form	A3	Customer	Check.	M. Michelsson	29-Jan-19	ACS880-104-R81-W600							Appr.	M. Asikainen	29-Jan-19	RITTAL VX25						Cost. No.	Project name									DMS Number	3AXD10000816615																	ABB										Doc. des. ASSEMBLY DRAWING Resp. dept. A.2 LDBJ Doc. No. 3AXD500000347919 Sheet 10 of 12	
Based on	Prepared	M. Michelsson	29-Jan-19	Title	ASSEMBLY DRAWING	Scale	3:100	Form	A3																																																																				
Customer	Check.	M. Michelsson	29-Jan-19	ACS880-104-R81-W600																																																																									
	Appr.	M. Asikainen	29-Jan-19	RITTAL VX25																																																																									
Cost. No.	Project name																																																																												
DMS Number	3AXD10000816615																																																																												
								ABB																																																																					
								Doc. des. ASSEMBLY DRAWING Resp. dept. A.2 LDBJ Doc. No. 3AXD500000347919 Sheet 10 of 12																																																																					

Stage 6: Installation of shrouding

1	2	3	4	5	6	7	8
<p>3AXD5000034719 ASSEMBLY DRAWING A. Initial Approval</p>							
<p>WE EXCEPT ALL RIGHTS IN THIS DOCUMENT AND IN THE INFORMATION CONTAINED HEREIN. REPRODUCTION, USE OR DISSEMINATION OF THIS DOCUMENT OR ANY PART THEREOF WITHOUT EXPRESS WRITTEN PERMISSION IS STRICTLY FORBIDDEN. © ABB LTD. PROPRIETARY AND CONFIDENTIAL INFORMATION. CONFIDENTIAL</p>							
<p>Prepared by: M. Michelsson 29-Jan-19 Checked by: M. Michelsson 29-Jan-19 Drawn by: M. Michelsson 29-Jan-19 Project name: 3AXD10000381661.5 Weight: kg</p>							
<p>Based on: M. Michelsson 29-Jan-19 Checked by: M. Michelsson 29-Jan-19 Drawn by: M. Michelsson 29-Jan-19 Project name: 3AXD10000381661.5 Weight: kg</p>							
<p>Title: ASSEMBLY DRAWING Part: R8i W600 Part No.: 3AXD5000034719 Part Name: R8i W600 Part Desc: R8i W600 Part Unit: 1 Part Weight: 12</p>							
<p>Doc. No.: 3AXD5000034719 Part No.: 3AXD5000034719 Part Name: R8i W600 Part Desc: R8i W600 Part Unit: 1 Part Weight: 12</p>							

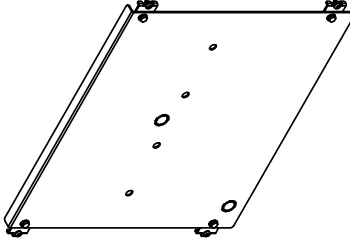

Ordering code: 3AXD50000337378
 KIT A-6-8-360-VX

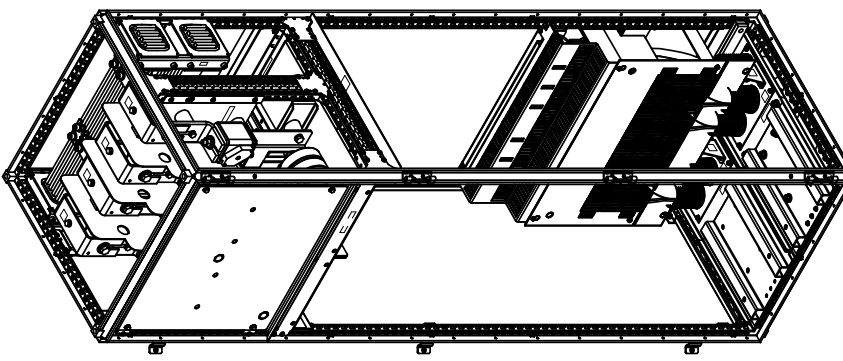

STAGE 6: R8i SHROUD INST. PARTS W600 installation

See assembly drawing 3AXD50000335022 for details and required additional Rittal and standard parts.



Stage 7: Installation of inverter modules

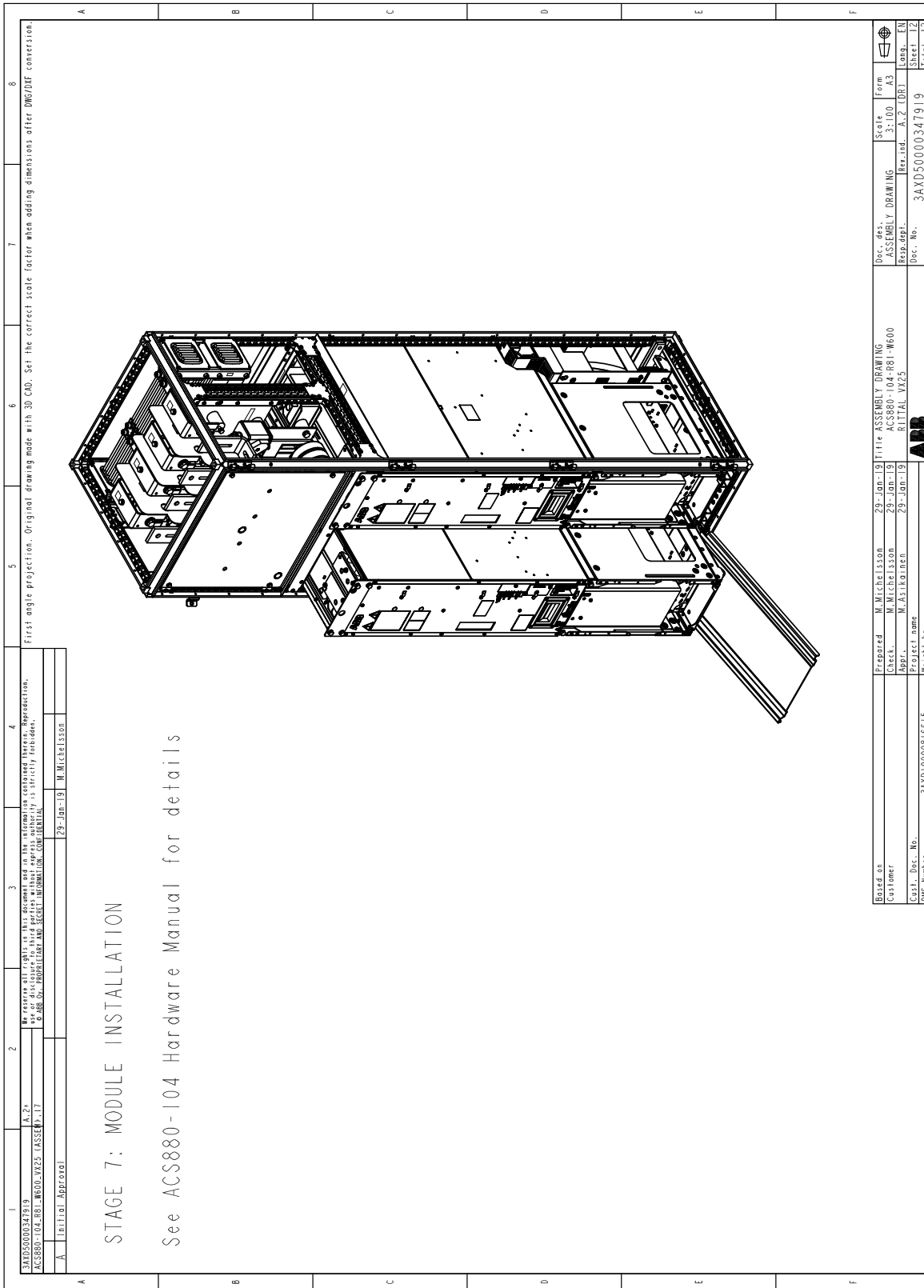

First angle projection. Original drawing made with 3D CAD. Set the correct scale factor when adding dimensions after DWG/DXF conversion.

All rights reserved. No part of this document may be reproduced, stored in a retrieval system, or transmitted, in any form or by any means, electronic, mechanical, photocopying, recording, or by any information storage and retrieval system, without the prior written permission of ABB.

3AXD5000347919	A.21	29-Jan-19	M. Michelsson
ACS880-104-R81-W600-VX25 (ASSEMBLY)			
A	Initial Approval		

STAGE 7: MODULE INSTALLATION

See ACS880-104 Hardware Manual for details

Based on	Prepared	M. Michelsson	29-Jan-19	Title	ASSEMBLY DRAWING	Scale	3:100	Form	A3
Customer	Check.	M. Michelsson	29-Jan-19	ACS880-104-R81-W600		ASSEMBLY DRAWING			
Customer	Appr.	M. Asikainen	29-Jan-19	RITTAL VX25					
DWG Number	3AXD10000816615	Weight	kg	ABB					
Doc. No.	3AXD50000347919	Dec. des. ASSEMBLY DRAWING Resp. dept. A.2 (DR) Lang. EN Dec. No. 3AXD50000347919 Sheet 12 of 12							

■ One R8i module in a 400 mm wide generic enclosure

Parts installed	Instruction code	Kit code	Kit ordering code
DC switch/charging mechanics (optional)	3AXD50000043644	A-4-8-292	3AXD50000044559
DC busbars (without DC switch/charging):			
Busbar assembly	3AXD50000006441	A-4-8-256	3AXD50000006418
DC busbars with common mode filters (filters not included in kit)	3AXD50000028418	A-468-8-235	3AXD50000028401
DC connection flanges	3AXD50000028384	A-468-8-246	3AXD50000028403
DC busbars (with DC switch/charging):			
Busbar assembly	3AXD50000043686	A-4-8-295	3AXD50000044582
DC busbars with common mode filters (filters not included in kit)	3AXD50000043411	A-468-8-247	3AXD50000044551
DC connection flanges	3AXD50000043466	A-468-8-248	3AXD50000044553
Module mechanical installation parts, lead-throughs:			
Module top/bottom guides	3AXD50000005874	A-4-8-315	3AXD50000005875
Lead-throughs	3AXD50000004817	A-468-8-441	3AXD50000004385
Quick connector, output (AC) busbars:			
Quick connector	3AUA0000118667	A-468-8-100	3AUA0000119227
Busbars and shrouds	3AXD50000006497	A-4-8-135	3AXD50000006435
Inverter module	-	-	-
Shrouding	-	-	-



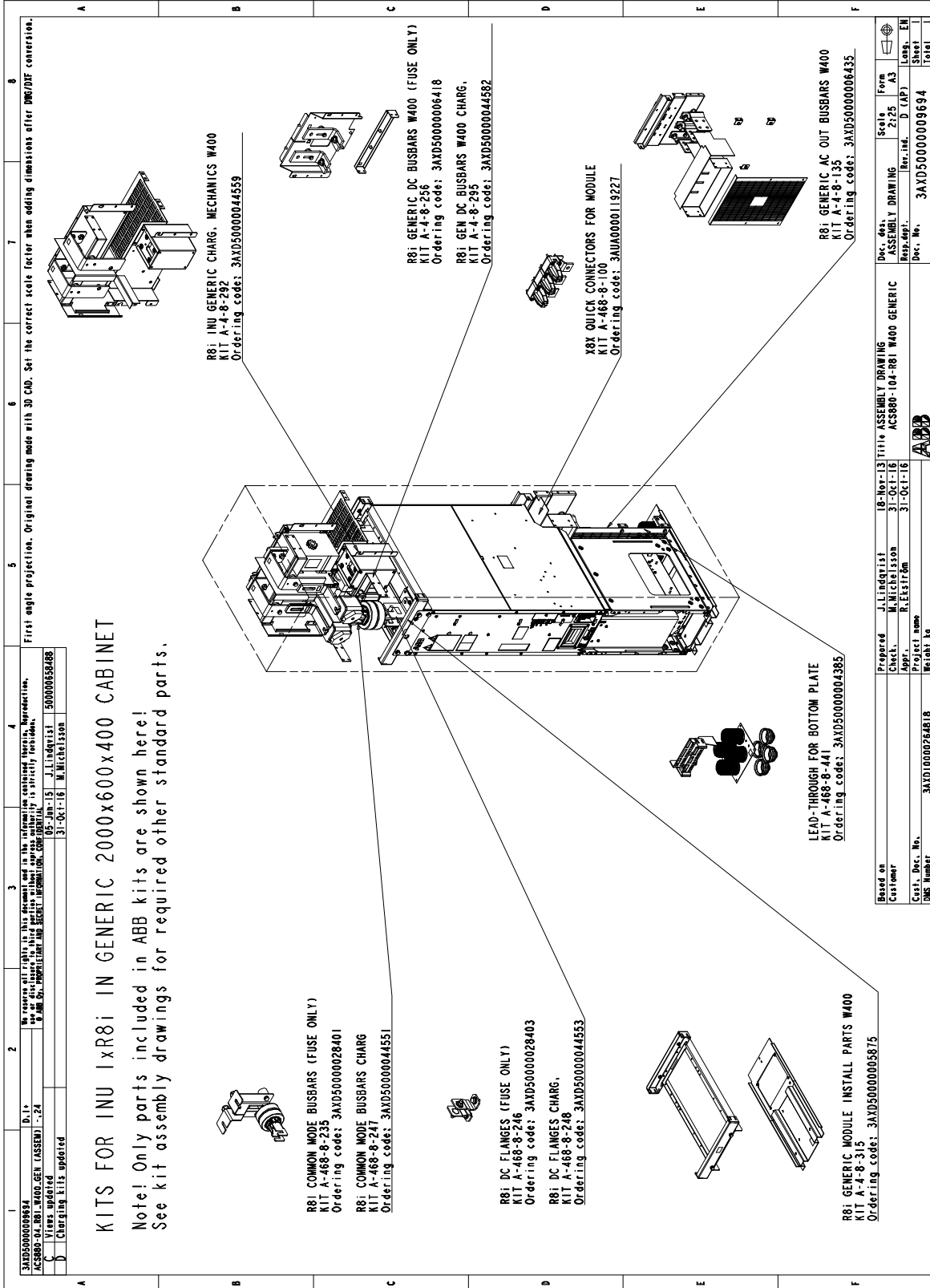

Doc. No.	3AXD50000009694	Scale	2:25	Form	A3
ASSEMBLY DRAWING		Rev. No.	D (CAP)	Long.	EN
Doc. No.	3AXD50000009694	Sheet	1	Total	1

■ Two R8i modules in a 600 mm wide generic enclosure

Parts installed	Instruction code	Kit code	Kit ordering code
DC switch/charging mechanics (optional)	3AXD50000043784	A-6-8-293	3AXD50000044560
DC busbars (without DC switch/charging):			
Busbar assembly	3AXD50000006447	A-6-8-257	3AXD50000006444
DC busbars with common mode filters (filters not included in kit)	3AXD50000028418	A-468-8-235	3AXD50000028401
DC connection flanges	3AXD50000028384	A-468-8-246	3AXD50000028403
DC busbars (with DC switch/charging):			
Busbar assembly	3AXD50000043737	A-6-8-296	3AXD50000044583
DC busbars with common mode filters (filters not included in kit)	3AXD50000043411	A-468-8-247	3AXD50000044551
DC connection flanges	3AXD50000043466	A-468-8-248	3AXD50000044553
Module mechanical installation parts, lead-throughs:			
Module top/bottom guides	3AXD50000005864	A-6-8-311	3AXD50000005876
Lead-throughs	3AXD50000004817	A-468-8-441	3AXD50000004385
Quick connector, output (AC) busbars:			
Quick connector	3AUA0000118667	A-468-8-100	3AUA0000119227
Busbars and shrouds (without bridging)	3AXD50000006489	A-6-8-136	3AXD50000006491
Busbars and shrouds (with bridging)	3AXD50000006505	A-6-8-138	3AXD50000006493
Inverter module	-	-	-
Shrouding	-	-	-



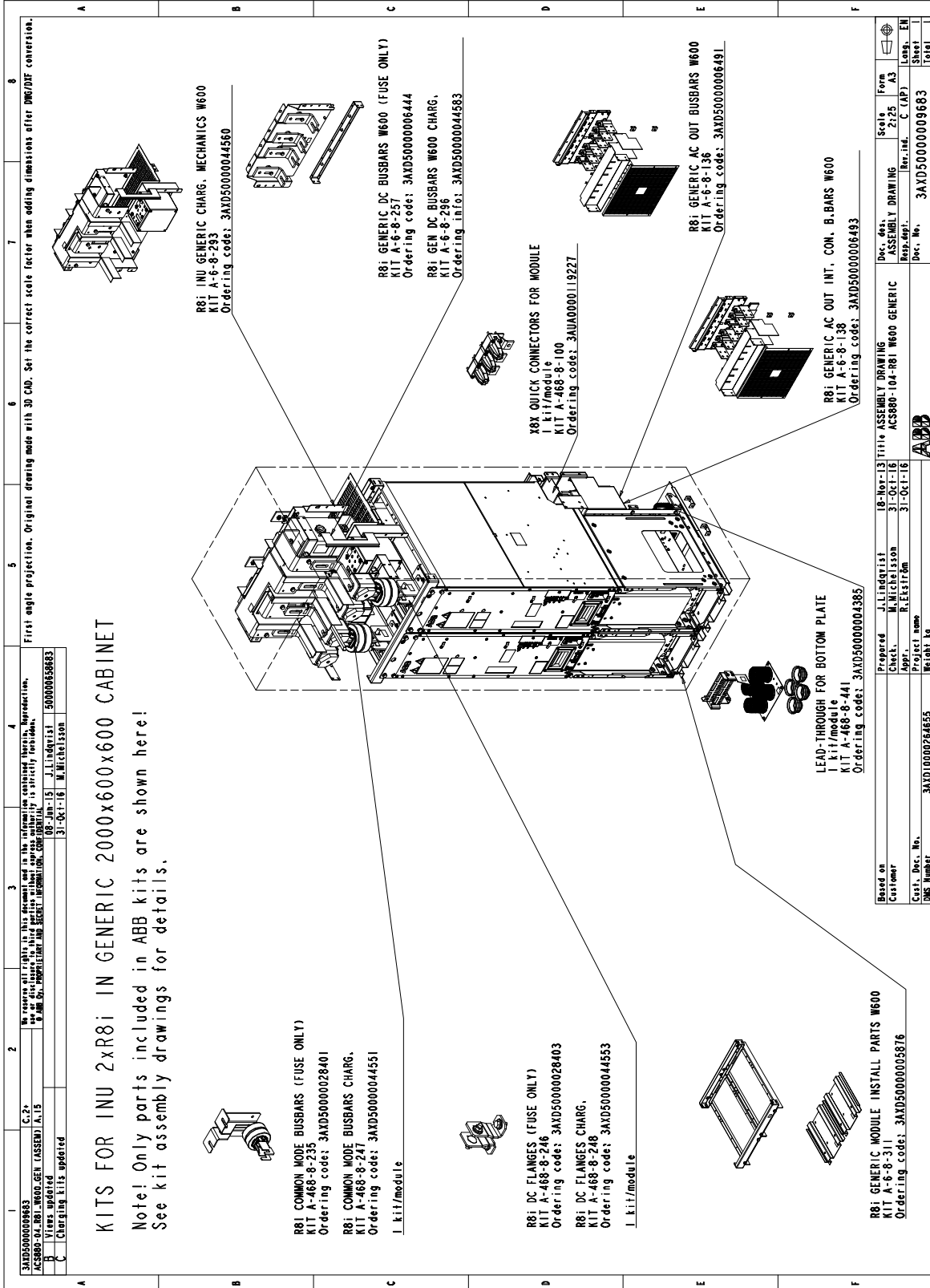

■ Three R8i modules in a 800 mm wide generic enclosure

Parts installed	Instruction code	Kit code	Kit ordering code
DC switch/charging mechanics (optional)	3AXD50000044586	A-8-8-294	3AXD50000044581
DC busbars (without DC switch/charging):			
Busbar assembly	3AXD50000006455	A-8-8-258	3AXD50000006450
DC busbars with common mode filters (filters not included in kit)	3AXD50000028418	A-468-8-235	3AXD50000028401
DC connection flanges	3AXD50000028384	A-468-8-246	3AXD50000028403
DC busbars (with DC switch/charging):			
Busbar assembly	3AXD50000044574	A-8-8-297	3AXD50000044584
DC busbars with common mode filters (filters not included in kit)	3AXD50000043411	A-468-8-247	3AXD50000044551
DC connection flanges	3AXD50000043466	A-468-8-248	3AXD50000044553
Module mechanical installation parts, lead-throughs:			
Module top/bottom guides	3AXD50000005848	A-8-8-312	3AXD50000005877
Lead-throughs	3AXD50000004817	A-468-8-441	3AXD50000004385
Quick connector, output (AC) busbars:			
Quick connector	3AUA0000118667	A-468-8-100	3AUA0000119227
Busbars and shrouds (without bridging)	3AXD50000006503	A-8-8-137	3AXD50000006492
Busbars and shrouds (with bridging)	3AXD50000006498	A-8-8-139	3AXD50000006494
Inverter module	-	-	-
Shrouding	-	-	-



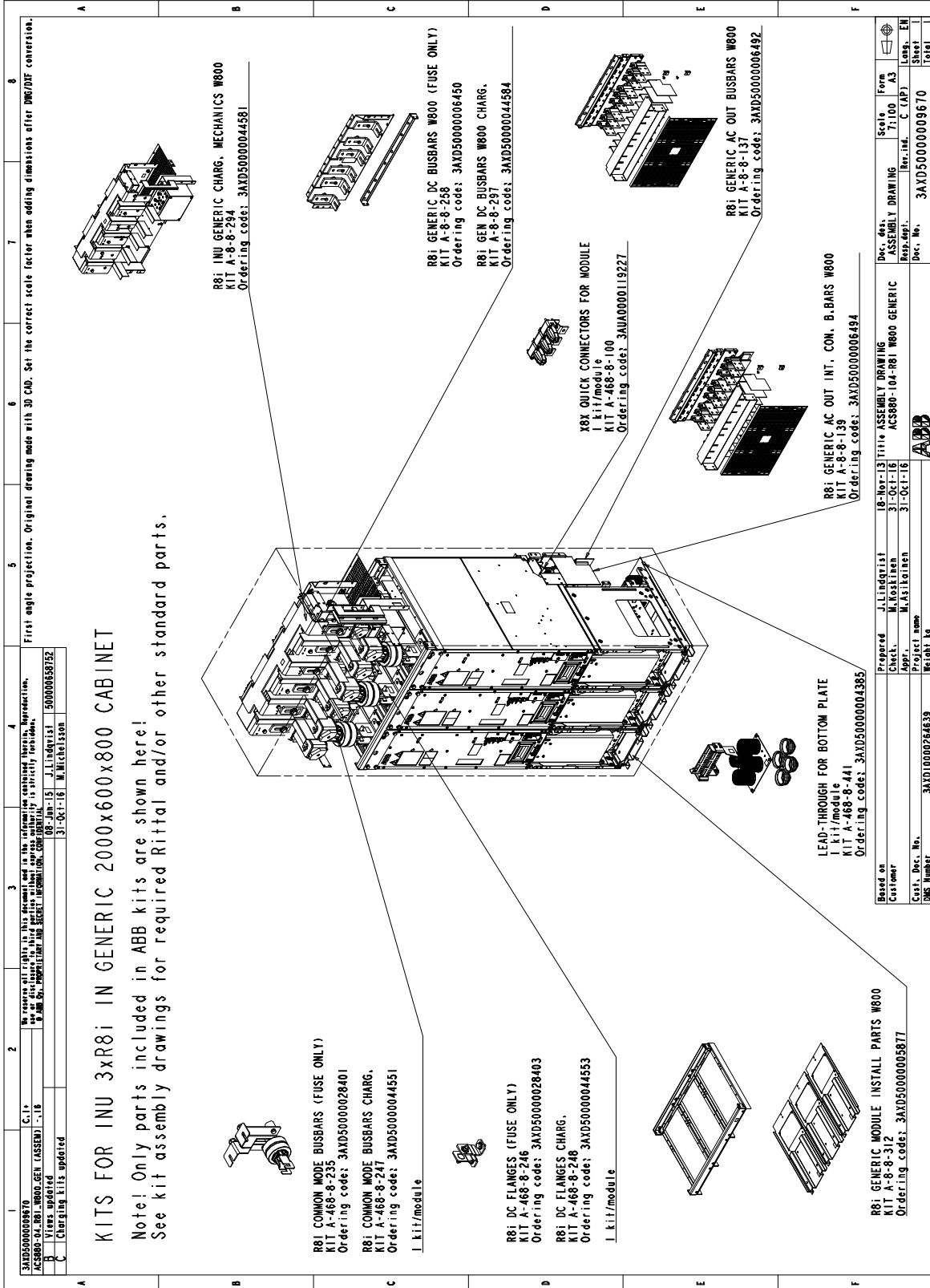

- One BLHF filter in a 600 mm wide Rittal VX25 enclosure

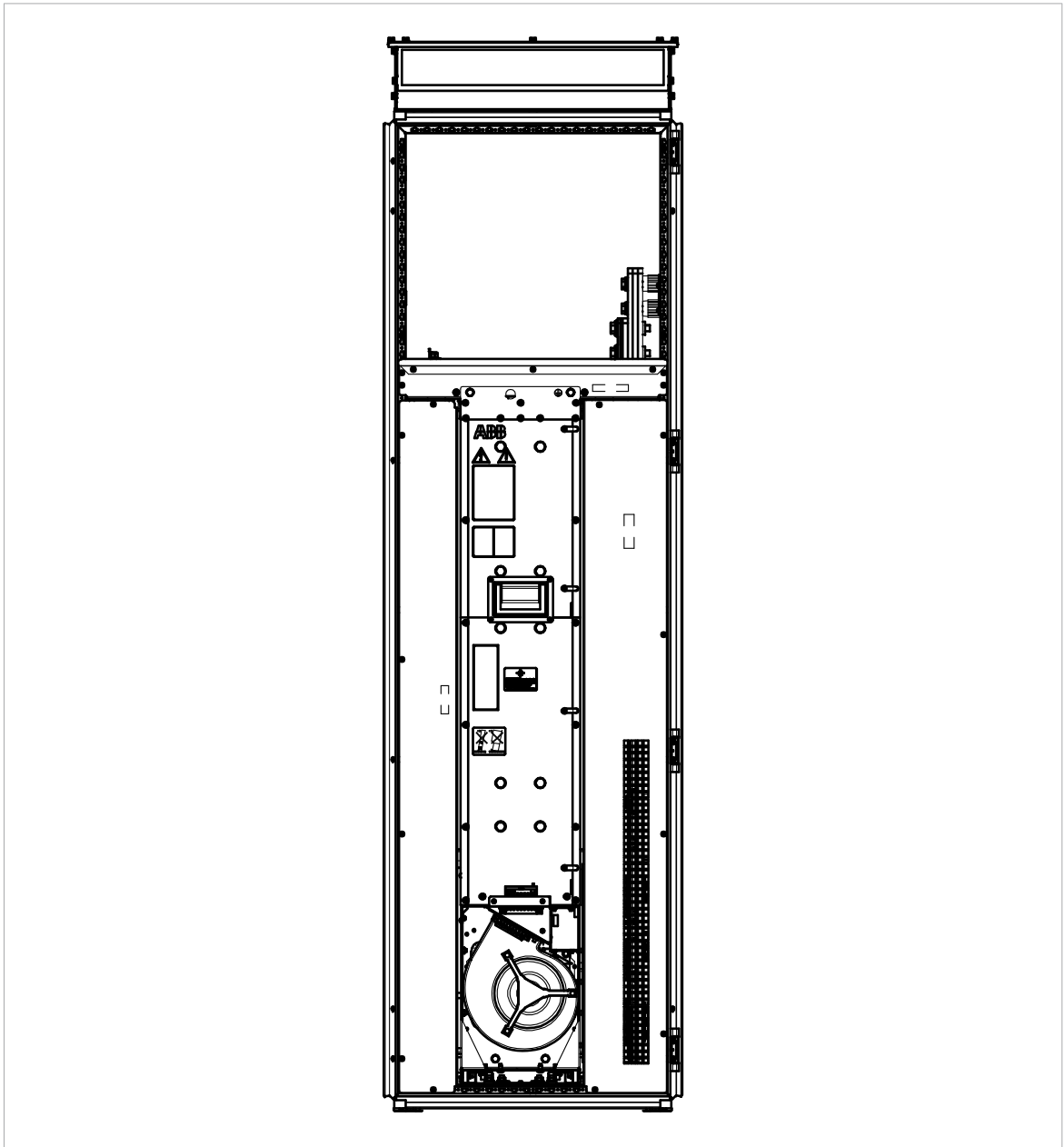

Installation stages

#	Installation stage	Instruction code	Kit code	Kit ordering code
1	Common parts:			
	Baying parts	3AXD50000336340	-	-
	PE busbar	3AXD50000336104	-	-
	Divider panel	3AXD50000336692	-	-
2	Module installation parts:			
	Module top/bottom guides	3AXD50000883684	A-6-8-335-VX	3AXD50000883080
3	AC busbars and AC input busbars installation:			
	AC busbars	3AXD50000887231	A-6-8-112-VX	3AXD50000883103
	AC input busbars	3AXD50000887347	A-6-8-118-VX	3AXD50000885053
4	Filter module, AC flanges and shrouds installation:			
	AC flanges	3AXD50000884216	A-X-8-149	3AXD50000883219
	Shrouds	3AXD50000887286	A-6-8-362-VX	3AXD50000883226

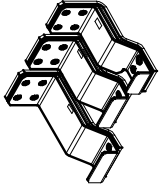
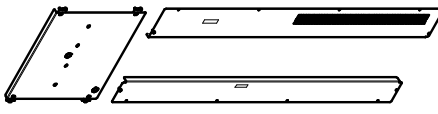
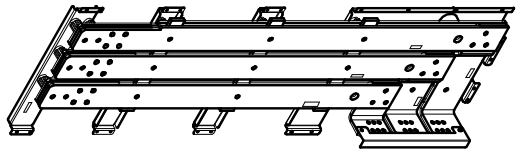
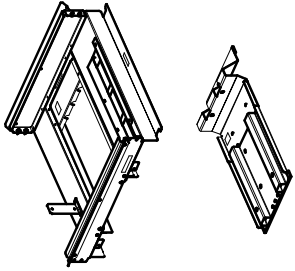
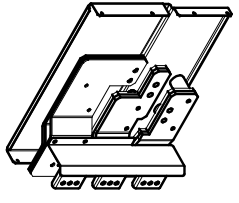
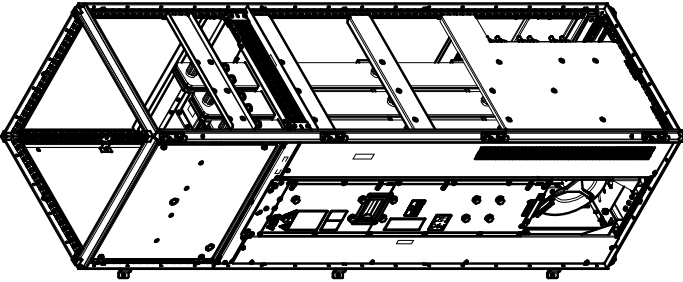

Overview of kits

1	2	3	4	5	6	7	8																																										
<p>3AXD5000883009 HSFU AC BUSBARS W600</p> <p style="font-size: small;">We reserve all rights on this document and in the information contained therein. Reproduction, use or disclosure to third parties without express authorisation is strictly forbidden. © ABB Ltd.</p> <p style="font-size: small;">Approved by: M. Michelsson Date: 01-Mar-22</p>																																																	
<p>KITS FOR HSFU IxBLHF IN RITTAL VX25 2000x600x600</p> <p>Note! Only parts included in ABB kits are shown here. See assembly drawings for required Rittal and/or standard parts.</p>																																																	
A	B	C	D	E	F																																												
 <p>HSFU AC FLANGES KIT A-X-8-I49 Ordering code: 3AXD50000883219</p>		 <p>HSFU SHROUDS W600 KIT A-6-8-362-VX Ordering code: 3AXD50000883226</p>		 <p>HSFU AC BUSBARS W600 KIT A-6-8-112-VX Ordering code: 3AXD50000883103</p>																																													
 <p>HSFU MODULE INST. PARTS W600 KIT A-6-8-335-VX Ordering code: 3AXD50000883080</p>				 <p>HSFU AC INPUT BUSBARS W600 KIT A-6-8-118-VX Ordering code: 3AXD50000885053</p>																																													
																																																	
<p>First-angle projection. Original drawing made with 3D CAD. Set the correct scale factor when adding dimensions after DWG/DXF conversion.</p>																																																	
<table border="1" style="width: 100%; border-collapse: collapse; font-size: x-small;"> <tr> <td>Based on:</td> <td>M. Michelsson</td> <td>01-Mar-22</td> <td>Title</td> <td>ASSEMBLY DRAWING</td> <td>Scale</td> <td>Form</td> </tr> <tr> <td>Customer:</td> <td>ABB</td> <td></td> <td>Project name</td> <td>HSFU AC INPUT BUSBARS W600</td> <td>3:100</td> <td>A3</td> </tr> <tr> <td>Created:</td> <td>M. Michelsson</td> <td>01-Mar-22</td> <td>Project name</td> <td>RITTAL VX25 W600</td> <td>Rev. no.</td> <td>EN</td> </tr> <tr> <td>Drawn:</td> <td>M. Michelsson</td> <td>01-Mar-22</td> <td>Weight:</td> <td></td> <td>Sheet</td> <td>5</td> </tr> <tr> <td>DWG. No.:</td> <td>3AXD10001542356</td> <td></td> <td></td> <td></td> <td>Sheet</td> <td>5</td> </tr> <tr> <td></td> <td></td> <td></td> <td></td> <td></td> <td>Total</td> <td>5</td> </tr> </table>								Based on:	M. Michelsson	01-Mar-22	Title	ASSEMBLY DRAWING	Scale	Form	Customer:	ABB		Project name	HSFU AC INPUT BUSBARS W600	3:100	A3	Created:	M. Michelsson	01-Mar-22	Project name	RITTAL VX25 W600	Rev. no.	EN	Drawn:	M. Michelsson	01-Mar-22	Weight:		Sheet	5	DWG. No.:	3AXD10001542356				Sheet	5						Total	5
Based on:	M. Michelsson	01-Mar-22	Title	ASSEMBLY DRAWING	Scale	Form																																											
Customer:	ABB		Project name	HSFU AC INPUT BUSBARS W600	3:100	A3																																											
Created:	M. Michelsson	01-Mar-22	Project name	RITTAL VX25 W600	Rev. no.	EN																																											
Drawn:	M. Michelsson	01-Mar-22	Weight:		Sheet	5																																											
DWG. No.:	3AXD10001542356				Sheet	5																																											
					Total	5																																											



Stage 1: Installation of common parts

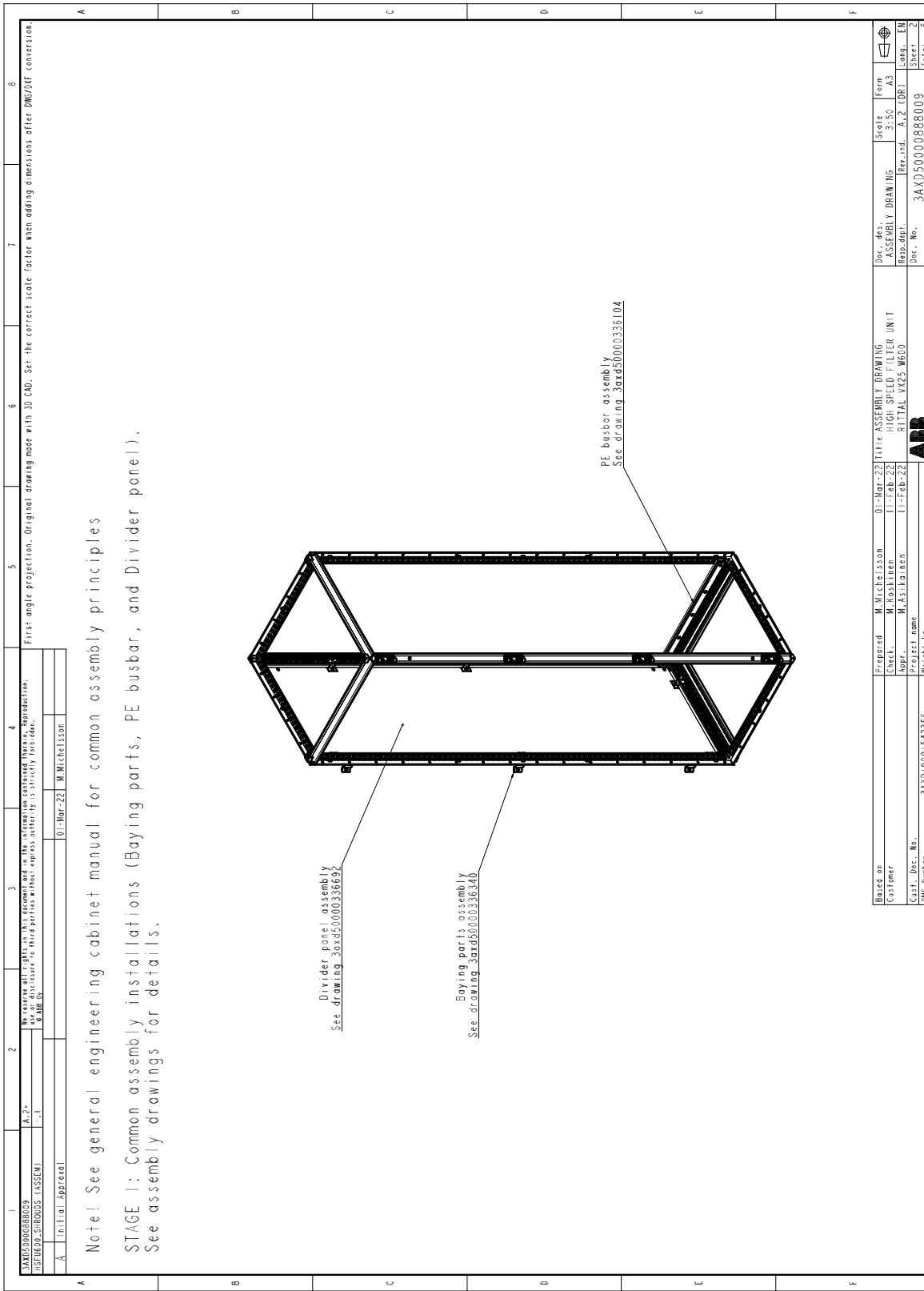

Note! See general engineering cabinet manual for common assembly principles

STAGE 1: Common assembly installations (Baying parts, PE busbar, and Divider panel).
See assembly drawings for details.

Divider panel assembly
See drawing 3axd5000336692

Baying parts assembly
See drawing 3axd5000336340

PE busbar assembly
See drawing 3axd5000336104

First angle projection. Original drawing made with 3D CAD. Set the correct scale factor when adding dimensions after DWG/DXF conversion.

3AXD500088009	A-Z	1	2	3	4	5	6	7	8
JUSTUO SHIRODS (ASSEM)
Initial Approval		01-Mar-22		M. Michelsson					

Based on	Prepared	M. Michelsson	01-Mar-22	Title	ASSEMBLY DRAWING	Scale	Form
Customer	Checked	M. Koskinen	11-Feb-22	HIGH SPEED FILTER UNIT	ASSEMBLY DRAWING	3:50	A3
	Appr.	M. Asikainen	11-Feb-22	RITTAL VX25 W600	Per. no.	A,2 (DR)	Lang. EN
Customer No.	Project name			ABB			
DWG Number	3AXD-0001542355	Merkitä		Doc. No. 3AXD500088009			
				Sheet 2			
				Total 3			

Stage 2: Installation of module installation parts

1	2	3	4	5	6	7	8	
3AXD5000888009 (USE 600 VICES ASSEMBLY)		No reserve all parts on this document and in the information contained therein in reproduction. Use of disclosure to third parties without express authorisation is strictly forbidden. © ABB Ltd.		First-angle projection. Original drawing made with 3D CAD. Set the correct scale factor when adding dimensions after DWG/DXF conversion.				Doc. No. 3AXD5000888009
A Initial Approval		01-Mar-22 M. Michelissson						Scale 3:100
								Form A3
								Drawn A.2 LOBY
								Checked M. Michelissson
								Released A.2 LOBY
								Part No. 3AXD5000888009
								Title ASSEMBLY DRAWING
								Description RITTAL VICE2 W600
								Project name 3AXD10001542356
								Weight kg
								Unit EV
								Sheet 3
								Total 5

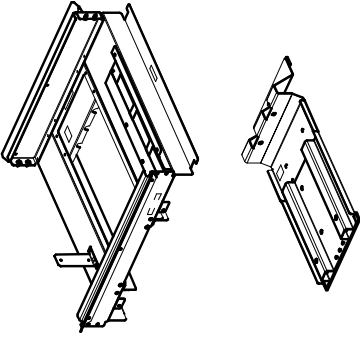

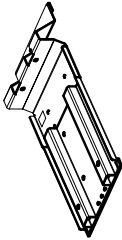

HSFU MODULE INST. PARTS W600
KIT A-6-8-335-VX
Ordering code: 3AXD5000883080

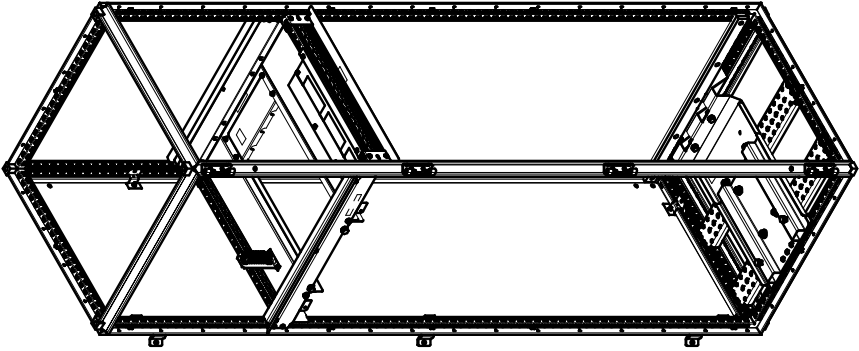

STAGE 2: Module installation parts

See assembly drawing 3AXD5000883684 for details and required Rittal and standard parts.





Stage 3: Installation of AC busbars and AC input busbars

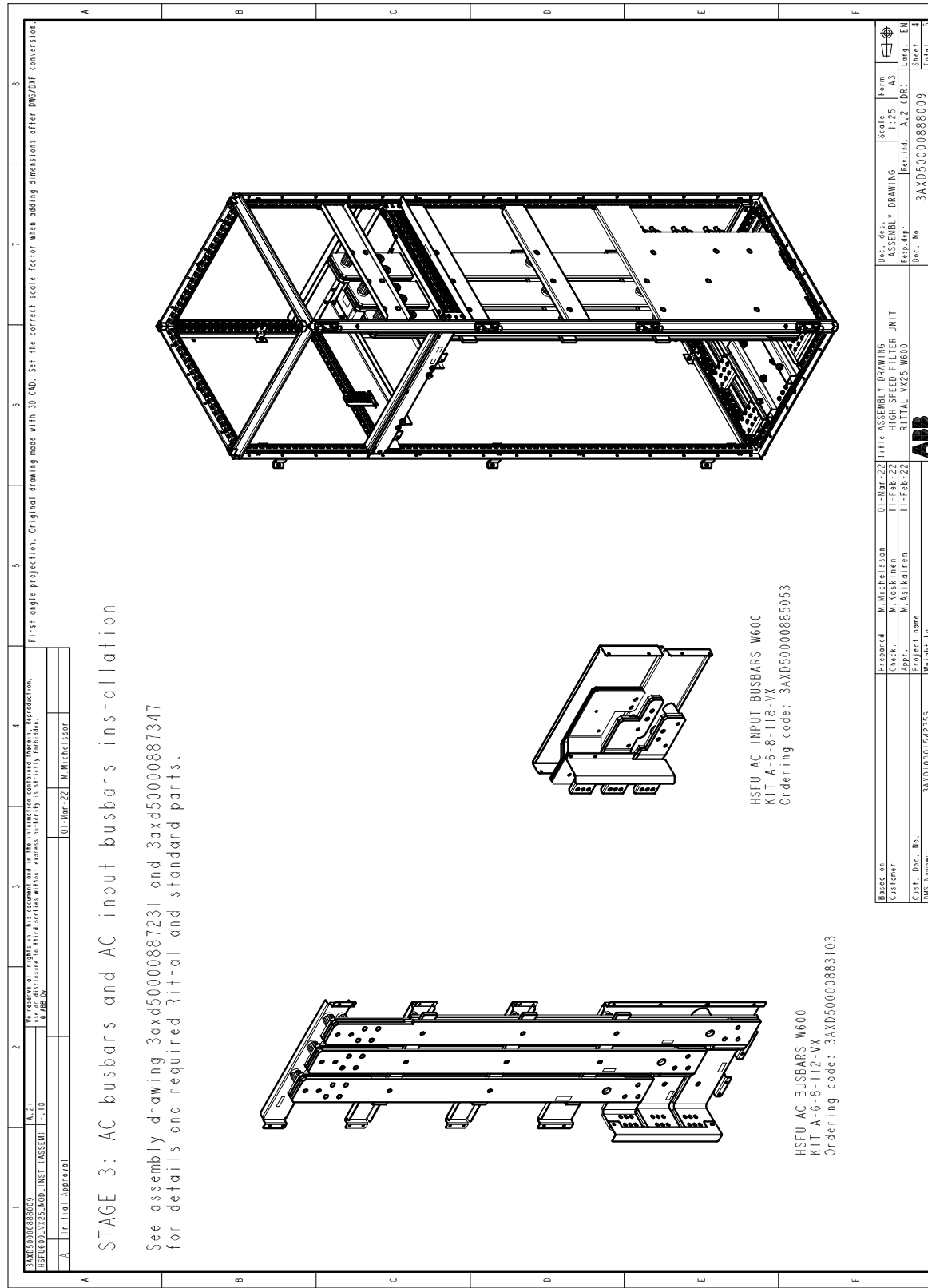

1
2
3
4
5
6
7
8

1
2
3
4
5
6
7
8

1
2
3
4
5
6
7
8

A
B
C
D
E
F

A
B
C
D
E
F

A
B
C
D
E
F

First angle projection. Original drawing made with 3D CAD. Set the correct scale factor when adding dimensions after DWG/DXF conversion.

No reserve of rights in this document and in the information contained here-in. Reproduction is allowed without charge insofar as it is not intended for general distribution.

© 2022 ABB Oy

Stage 4: Installation of filter module, AC flanges and shrouds

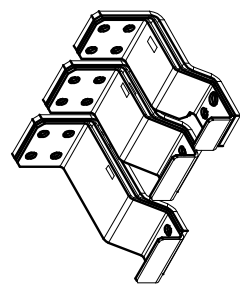
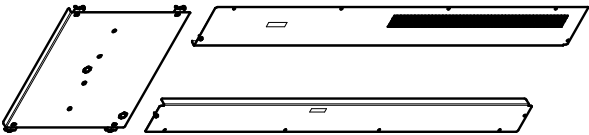
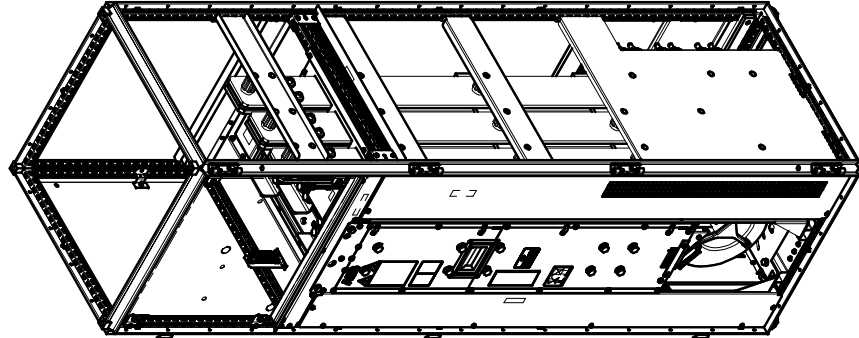
1	2	3	4	5	6	7	8
3AXD5000888009 HSFU AC BUSBARS ASSEMBLY KIT First-angle projection. Original drawing made with 3D CAD. Set the correct scale factor when adding dimensions after DWG/DXF conversion.							
Approved by: M. Michelsson Date: 01-Mar-22							
<p style="font-size: 12px; margin-top: 10px;">STAGE 4: Filter module, AC flanges and HSFU shrouds installation</p> <p style="font-size: 10px; margin-top: 5px;">See assembly drawing 3axd5000884216 and 3axd5000887286 for details and required Rittal and standard parts. See ACS880-104 HW Manual and ACS880 multidrive for high-speed test benches for details.</p>							
 <p style="font-size: 10px; margin-top: 5px;">HSFU AC FLANGES KIT A-X-8-149 Ordering code: 3AXD5000883219</p>				 <p style="font-size: 10px; margin-top: 5px;">HSFU SHROUDS W600 KIT A-6-8-362-VX Ordering code: 3AXD5000883226</p>			
							
Based on: M. Michelsson 01-Mar-22 Title: ASSEMBLY DRAWING HSFU AC BUSBARS ASSEMBLY KIT Checked: M. Michelsson 01-Mar-22 Drawn: M. Michelsson 01-Mar-22 Cust. Desc. No.: 3AXD10001542356 Project name: 3AXD5000888009 DMS Number: 3AXD10001542356 Weight: kg							
Doc. No.: 3AXD5000888009 Assembly Drawing Rev. No.: 1 Date: 01-Mar-22 Drawn by: M. Michelsson Checked by: M. Michelsson Title: ASSEMBLY DRAWING HSFU AC BUSBARS ASSEMBLY KIT Part No.: 3AXD5000888009 Scale: 1:1 Sheet: 1 of 1							



■ Two BLHF filters in a 800 mm wide Rittal VX25 enclosure

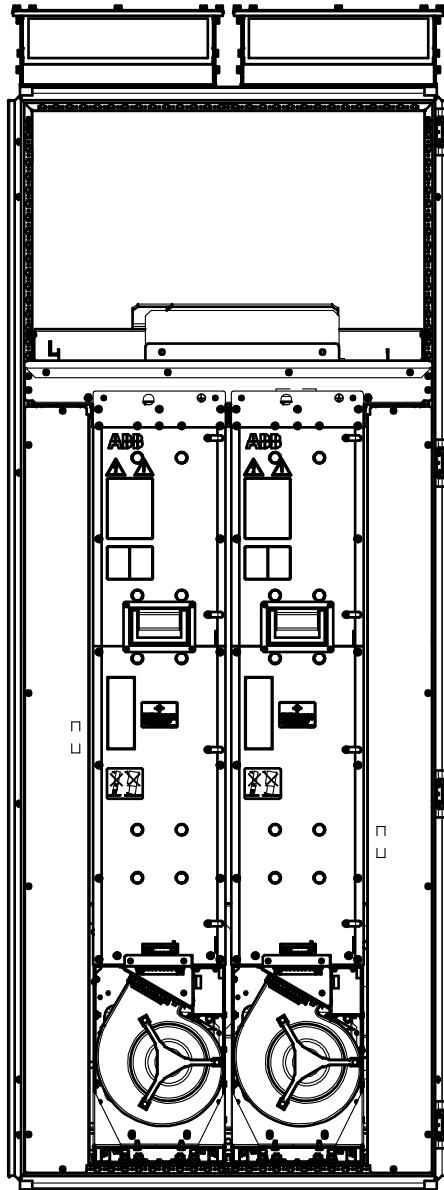

Installation stages

#	Installation stage	Instruction code	Kit code	Kit ordering code
1	Common parts:			
	Baying parts	3AXD50000336340	-	-
	PE busbar	3AXD50000336104	-	-
	Divider panel	3AXD50000336692	-	-
2	Module installation parts:			
	Module top/bottom guides	3AXD50000887408	A-8-8-336-VX	3AXD50000883233
3	AC busbars installation:			
	AC busbars	3AXD50000887569	A-8-8-113-VX	3AXD50000883257
4	Filter module, AC connection busbars and shrouds installation:			
	AC connection busbars	3AXD50000887576	A-8-8-116-VX	3AXD50000883264
	Shrouds	3AXD50000888016	A-8-8-363-VX	3AXD50000883271



Overview of kits

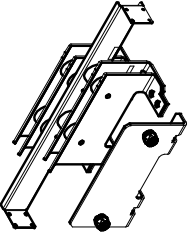
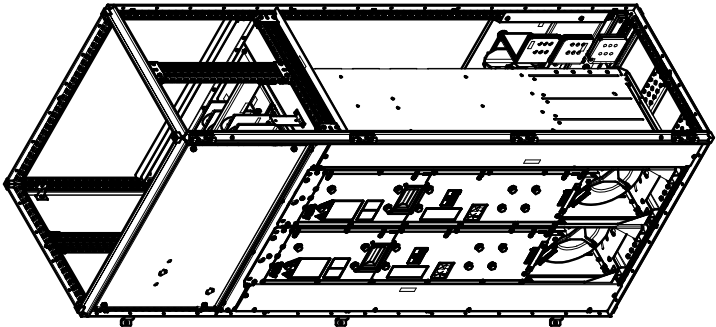
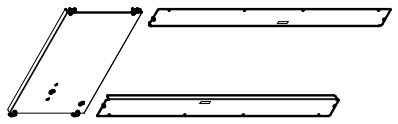
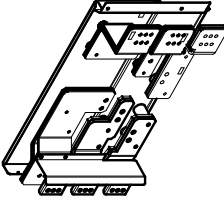
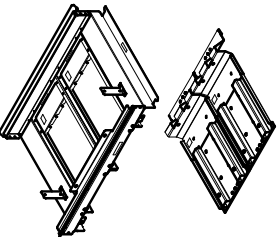

1	2	3	4	5	6	7	8																																																	
<p>3AXD5000088986 HSFUB00_VX25_ASSEM1</p> <p style="font-size: small;">No parts or rights in this document and in the information contained here are reproduced, stored in a retrieval system or transmitted in any form or by any means, electronic, mechanical, photocopying, recording, or by any information storage and retrieval system, without the prior written permission of ABB Oy.</p> <p style="font-size: small;">01-Mar-22 M. Michelsson</p> <p style="font-size: small;">Initial Approval</p>																																																								
<p style="text-align: center;">KITS FOR HSFU 2xBLHF IN RITTAL VX25 2000x800x600</p> <p style="text-align: center;">Note! Only parts included in ABB kits are shown here. See assembly drawings for required Rittal and/or standard parts.</p>																																																								
 <p style="text-align: center;">HSFU AC CONN. BUSBARS W800 KIT A-8-116-VX Ordering code: 3AXD50000883264</p>						 <p style="text-align: center;">HSFU SHROUDS W800 KIT A-8-363-VX Ordering code: 3AXD50000883271</p>																																																		
 <p style="text-align: center;">HSFU AC BUSBARS W600 KIT A-8-113-VX Ordering code: 3AXD50000883257</p>		 <p style="text-align: center;">HSFU MODULE INST. PARTS W800 KIT A-8-336-VX Ordering code: 3AXD50000883233</p>																																																						
<table border="1" style="width: 100%; border-collapse: collapse; font-size: x-small;"> <tr> <td>Based on</td> <td>M. Michelsson</td> <td>01-Mar-22</td> <td>Title</td> <td>ASSEMBLY DRAWING</td> <td>Scale</td> <td>Form</td> </tr> <tr> <td>Customer</td> <td>M. Koskinen</td> <td>16-Feb-22</td> <td>High Speed Filter Unit</td> <td>ASSEMBLY DRAWING</td> <td>3:100</td> <td>A3</td> </tr> <tr> <td>Appr.</td> <td>M. Asikainen</td> <td>16-Feb-22</td> <td>RITTAL VX25 W800</td> <td>Rev. no.</td> <td>A, 2 (DR)</td> <td></td> </tr> <tr> <td>Proj. name</td> <td colspan="2">3AXD5000088986</td> <td colspan="2">3AXD5000088986</td> <td>Sheet</td> <td>EN</td> </tr> <tr> <td>Proj. no.</td> <td colspan="2">3AXD5000088986</td> <td colspan="2">3AXD5000088986</td> <td>Sheet</td> <td>EN</td> </tr> <tr> <td>Proj. no.</td> <td colspan="2">3AXD5000088986</td> <td colspan="2">3AXD5000088986</td> <td>Sheet</td> <td>EN</td> </tr> <tr> <td>Proj. no.</td> <td colspan="2">3AXD5000088986</td> <td colspan="2">3AXD5000088986</td> <td>Sheet</td> <td>EN</td> </tr> </table>								Based on	M. Michelsson	01-Mar-22	Title	ASSEMBLY DRAWING	Scale	Form	Customer	M. Koskinen	16-Feb-22	High Speed Filter Unit	ASSEMBLY DRAWING	3:100	A3	Appr.	M. Asikainen	16-Feb-22	RITTAL VX25 W800	Rev. no.	A, 2 (DR)		Proj. name	3AXD5000088986		3AXD5000088986		Sheet	EN	Proj. no.	3AXD5000088986		3AXD5000088986		Sheet	EN	Proj. no.	3AXD5000088986		3AXD5000088986		Sheet	EN	Proj. no.	3AXD5000088986		3AXD5000088986		Sheet	EN
Based on	M. Michelsson	01-Mar-22	Title	ASSEMBLY DRAWING	Scale	Form																																																		
Customer	M. Koskinen	16-Feb-22	High Speed Filter Unit	ASSEMBLY DRAWING	3:100	A3																																																		
Appr.	M. Asikainen	16-Feb-22	RITTAL VX25 W800	Rev. no.	A, 2 (DR)																																																			
Proj. name	3AXD5000088986		3AXD5000088986		Sheet	EN																																																		
Proj. no.	3AXD5000088986		3AXD5000088986		Sheet	EN																																																		
Proj. no.	3AXD5000088986		3AXD5000088986		Sheet	EN																																																		
Proj. no.	3AXD5000088986		3AXD5000088986		Sheet	EN																																																		

Stage 1: Installation of common parts

1	2	3	4	5	6	7	8	
3AXD500088986 BUSBAR (V225, SHROUS) ASSEMBLY A.2* 1:1		We reserve all rights on this document and in the information contained herein. Reproduction, use or disclosure to third parties without express authorisation is strictly forbidden. © ABB Ltd.		First-angle projection. Original drawing made with 3D CAD. Set the correct scale factor when adding dimensions after DWG/DXF conversion.				Doc. No. ASSEMBLY DRAWING Rev. No. 3AXD50000888986
Initial Approval 01-Mar-22 M. Michelsson		Prepared by M. Michelsson 01-Mar-22		Checked by M. Michelsson 01-Mar-22		Title ASSEMBLY DRAWING BUSBAR (V225, SHROUS) UNIT INITIAL V225_W800		Scale 1:1 Form A2 Sheet 1 of 1
Note: See general engineering cabinet manual for common assembly principles STAGE 1: Common assembly installations (Baying parts, PE busbar and Divider panel). See assembly drawings for details.		Baying parts assembly See drawing 3axd5000336340		Divider panel assembly See drawing 3axd5000336692		PE busbar assembly See drawing 3axd5000336104		Part No. 3AXD10001543925 Weight kg



Stage 2: Installation of module installation parts

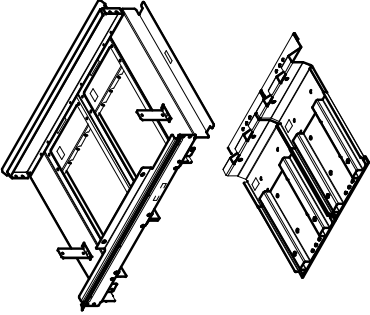
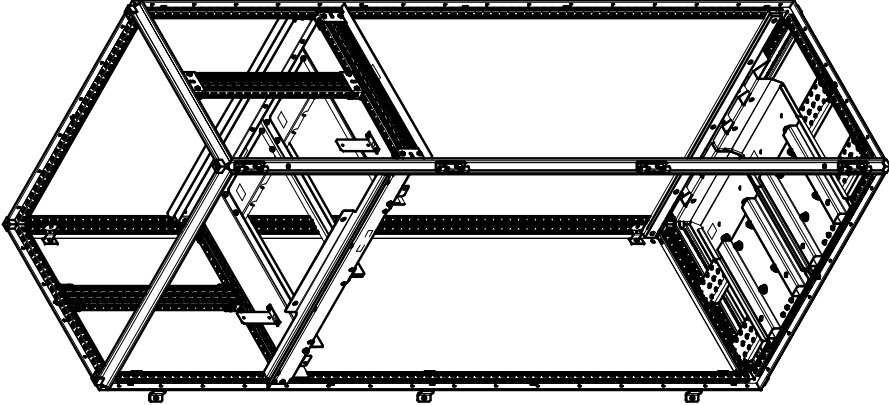

1	2	3	4	5	6	7	8
3AXD5000088986 HSFU800 VXZ5 (ASSEMB) A-Z -7 Initial Approval 01-Mar-22 M. Michelsson							
We reserve all rights in this document and in the information contained here in its reproduction. All rights are reserved. No part of this document may be reproduced without the prior written permission of ABB Oy.							
First angle projection. Original drawing made with 3D CAD. Set the correct scale factor when adding dimensions after DWG/DXF conversion.							
<p style="font-size: 14px; font-weight: bold;">STAGE 2: Module installation parts</p> <p>See assembly drawing 3AXD50000887408 for details and required Rittal and standard parts.</p>							
							
HSFU MODULE INST. PARTS W800 KIT A-8-8-336-VX Ordering code: 3AXD50000883233							
							
Based on: M. Michelsson 01-Mar-22 Title: ASSEMBLY DRAWING Scale: Form Customer: M. Koskinen 16-Feb-22 HIGH SPEED FILTER UNIT 3:100 A3 Appr.: M. Asikainen 16-Feb-22 RITTAL VXZ5 W800 Rev. def.: A, 2 (DR) Cont.: EN Project name: 3AXD5000088986 Rev. No.: 3AXD5000088986 Sheet: 3 Weight: kg 3AXD5000088986 Rev. No.: 3AXD5000088986 Sheet: 3							

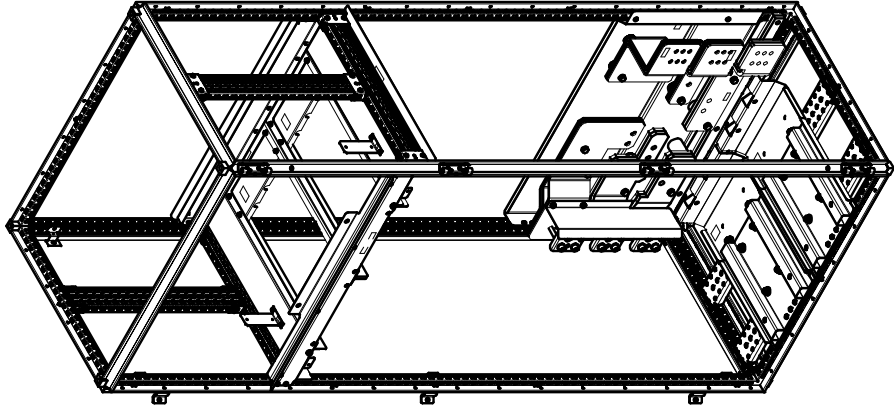
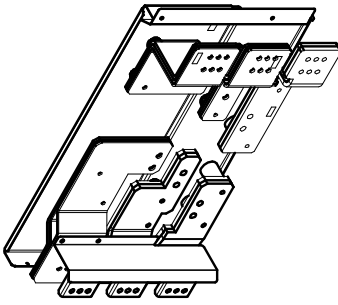

Stage 3: Installation of AC busbars

1	2	3	4	5	6	7	8	
3AXD500088986 HSFU AC BUSBARS - INST (ASSEMBLY)		No reserve rights in this document and in the information contained herein. Reproduction, use or disclosure to third parties without express authorisation is strictly forbidden. © ABB Ltd		First-angle projection. Original drawing made with 3D CAD. Set the correct scale factor when adding dimensions after DWG/DXF conversion.				Form No. 3 Sheet 4 of 5
A Initial Approval 01-Mar-22 M. Michelsson								Doc. No. 3AXD500088986 Assembly Drawing Rev. No. 1
Title: AC busbars W800 installation See assembly drawing 3axd5000887569 for details and required Rittal and standard parts.								HSFU AC BUSBARS W600 KIT A-8-113-VX Ordering code: 3AXD50000883257
Based on: Customer:		Prepared by: Checked by: Approved by:		M. Michelsson 01-Mar-22 M. Michelsson		Title: ASSEMBLY DRAWING Part: HSFU AC BUSBARS W600 Initial VZG2 W600		Form No. 3 Sheet 4 of 5
Cash. Desc. No. 3AXD10001543925 DMS Number:		Weight: kg		3AXD5000088986		Rev. No. 1		Form No. 3 Sheet 4 of 5



Stage 4: Installation of filter module, AC connection busbars and shrouds

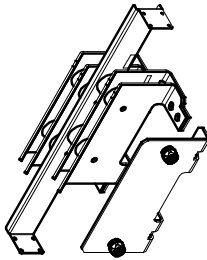
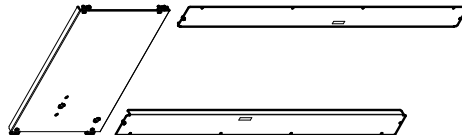
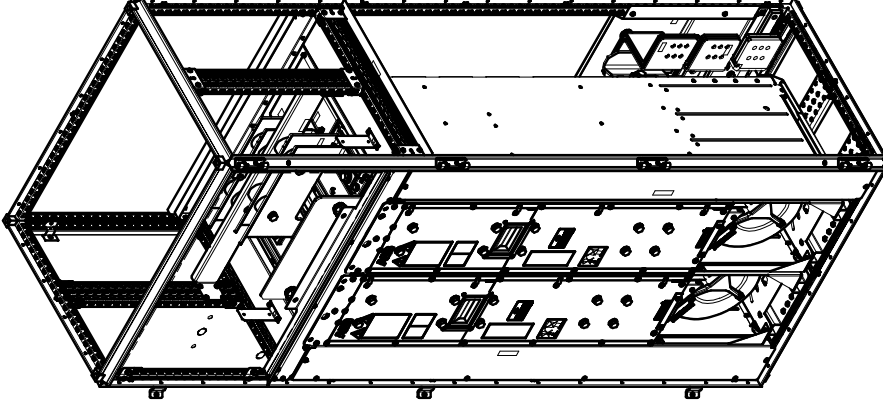

1	2	3	4	5	6	7	8																																																
A	B	C	D	E	F	G	H																																																
<p>3AXD5000088986 A-Z- We reserve all rights for this document and in the information contained here in its reproduction. First angle projection. Original drawing made with 3D CAD. Set the correct scale factor when adding dimensions after DWG/DXF conversion.</p> <p>3XBD00 VZ25 AC BUSBARS ASSEMBLY -5 © ABB Oy</p> <p style="text-align: right;">01-Mar-22 M. Michelsson</p>																																																							
<div style="display: flex; justify-content: space-between;"> <div style="width: 45%;"> <p>STAGE 4: Filter module, AC Conn. busbars and HSFU shrouds installation</p> <p>See assembly drawing 3AXD50000887576 and 3AXD50000888016 for details and required Rittal and standard parts. See ACS880-104 HW Manual and ACS880 multidrive for high-speed test benches for details.</p> </div> <div style="width: 45%; text-align: center;">  <p>HSFU AC CONN. BUSBARS W800 KIT A-8-8-116-VX Ordering code: 3AXD50000883264</p> </div> </div> <div style="display: flex; justify-content: center; align-items: center;">  <div style="margin-left: 20px;"> <p>HSFU SHROUDS W800 KIT A-8-8-363-VX Ordering code: 3AXD50000883271</p> </div> </div> <div style="text-align: center;">  </div>																																																							
<table border="1" style="width: 100%; border-collapse: collapse;"> <tr> <td style="width: 30%;">Based on:</td> <td style="width: 20%;">M. Michelsson</td> <td style="width: 20%;">01-Mar-22</td> <td style="width: 30%;">Title</td> </tr> <tr> <td>Customer:</td> <td>M. Koskinen</td> <td>16-Feb-22</td> <td>ASSEMBLY DRAWING</td> </tr> <tr> <td>Appr.:</td> <td>M. Asikainen</td> <td>16-Feb-22</td> <td>HIGH SPEED FILTER UNIT</td> </tr> <tr> <td>Proj. name:</td> <td colspan="3">RITTAL VXZ5 W800</td> </tr> <tr> <td>DWG. Number:</td> <td>3AXD50001545925</td> <td>Rev. No.:</td> <td>3AXD50000888986</td> </tr> <tr> <td></td> <td></td> <td></td> <td>Scale</td> </tr> <tr> <td></td> <td></td> <td></td> <td>1:10</td> </tr> <tr> <td></td> <td></td> <td></td> <td>Form</td> </tr> <tr> <td></td> <td></td> <td></td> <td>A3</td> </tr> <tr> <td></td> <td></td> <td></td> <td>Lang. EN</td> </tr> <tr> <td></td> <td></td> <td></td> <td>Sheet 5</td> </tr> <tr> <td></td> <td></td> <td></td> <td>of 5</td> </tr> </table>								Based on:	M. Michelsson	01-Mar-22	Title	Customer:	M. Koskinen	16-Feb-22	ASSEMBLY DRAWING	Appr.:	M. Asikainen	16-Feb-22	HIGH SPEED FILTER UNIT	Proj. name:	RITTAL VXZ5 W800			DWG. Number:	3AXD50001545925	Rev. No.:	3AXD50000888986				Scale				1:10				Form				A3				Lang. EN				Sheet 5				of 5
Based on:	M. Michelsson	01-Mar-22	Title																																																				
Customer:	M. Koskinen	16-Feb-22	ASSEMBLY DRAWING																																																				
Appr.:	M. Asikainen	16-Feb-22	HIGH SPEED FILTER UNIT																																																				
Proj. name:	RITTAL VXZ5 W800																																																						
DWG. Number:	3AXD50001545925	Rev. No.:	3AXD50000888986																																																				
			Scale																																																				
			1:10																																																				
			Form																																																				
			A3																																																				
			Lang. EN																																																				
			Sheet 5																																																				
			of 5																																																				



■ One BLHF filter in a 600 mm wide generic enclosure

Parts installed	Instruction code	Kit code	Kit ordering code
Module top/bottom guides	3AXD50000887224	A-6-8-337	3AXD50000883288
AC flanges	3AXD50000884216	A-X-8-149	3AXD50000883219
AC input busbars	3AXD50000887323	A-6-8-119	3AXD50000885060
AC busbars	3AXD50000887330	A-6-8-114	3AXD50000883295



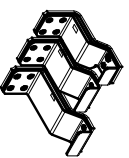
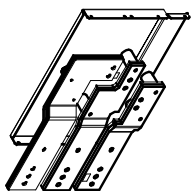
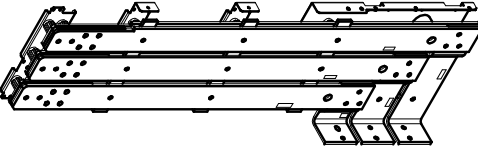
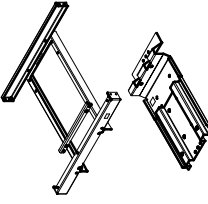
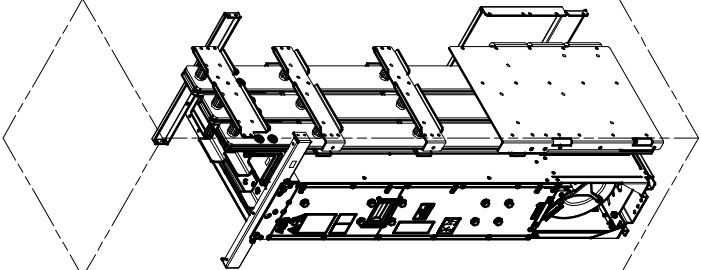

1	2	3	4	5	6	7	8																																			
<p>3AXD000088970 HSFU AC GENERIC (ASSEMBLY)</p> <p style="font-size: small;">We reserve all rights in this document and in the information contained therein, reproduction, in whole or in part, is prohibited without express authority in writing by ABB Oy.</p> <p style="font-size: small;">First angle projection. Original drawing made with 3D CAD. Set the correct scale factor when adding dimensions after DWG/DXF conversion.</p>																																										
<p style="text-align: center;">A Initial Approval</p> <p style="text-align: center;">01-Mar-22 M. Michelsson</p>																																										
<h2>KITS FOR HSFU IxBLHF IN GENERIC 2000x600x600 CABINET</h2> <p>Note! Only parts included in ABB kits are shown here. See assembly drawings for required Rittal and/or standard parts.</p>																																										
 HSFU AC FLANGES KIT A-X-8-149 Ordering code: 3AXD50000883219		 HSFU AC INPUT BUSBARS W600 GEN KIT A-6-8-114 Ordering code: 3AXD50000885060		 HSFU AC BUSBARS W600 GEN KIT A-6-8-114 Ordering code: 3AXD50000883295		 HSFU MODULE INST. PARTS W600 GEN KIT A-6-8-337 Ordering code: 3AXD50000883288																																				
																																										
<table border="1" style="width: 100%; border-collapse: collapse;"> <tr> <td style="width: 20%;">Based on</td> <td style="width: 20%;">M. Michelsson</td> <td style="width: 20%;">01-Mar-22</td> <td style="width: 20%;">Title</td> <td style="width: 20%;">ASSEMBLY DRAWING</td> <td style="width: 10%;">Scale</td> <td style="width: 10%;">Form</td> </tr> <tr> <td>Customer</td> <td>M. Koskinen</td> <td>16-Feb-22</td> <td>HIGH SPEED FILTER UNIT</td> <td>ASSEMBLY DRAWING</td> <td>1:25</td> <td>A3</td> </tr> <tr> <td>Project name</td> <td>M. Asikainen</td> <td>16-Feb-22</td> <td>GENERIC W600</td> <td>Rev. no.</td> <td>A.0 (DR)</td> <td>Sheet</td> </tr> <tr> <td>Proj. Doc. No.</td> <td></td> <td></td> <td></td> <td>Doc. No.</td> <td>3AXD5000088970</td> <td>Total</td> </tr> <tr> <td>DWG Number</td> <td>3AXD10001545817</td> <td></td> <td></td> <td></td> <td></td> <td></td> </tr> </table>								Based on	M. Michelsson	01-Mar-22	Title	ASSEMBLY DRAWING	Scale	Form	Customer	M. Koskinen	16-Feb-22	HIGH SPEED FILTER UNIT	ASSEMBLY DRAWING	1:25	A3	Project name	M. Asikainen	16-Feb-22	GENERIC W600	Rev. no.	A.0 (DR)	Sheet	Proj. Doc. No.				Doc. No.	3AXD5000088970	Total	DWG Number	3AXD10001545817					
Based on	M. Michelsson	01-Mar-22	Title	ASSEMBLY DRAWING	Scale	Form																																				
Customer	M. Koskinen	16-Feb-22	HIGH SPEED FILTER UNIT	ASSEMBLY DRAWING	1:25	A3																																				
Project name	M. Asikainen	16-Feb-22	GENERIC W600	Rev. no.	A.0 (DR)	Sheet																																				
Proj. Doc. No.				Doc. No.	3AXD5000088970	Total																																				
DWG Number	3AXD10001545817																																									



■ Two BLHF filters in a 800 mm wide generic enclosure

Parts installed	Instruction code	Kit code	Kit ordering code
Module top/bottom guides	3AXD50000887071	A-8-8-338	3AXD50000883318
AC busbars	3AXD50000887316	A-8-8-115	3AXD50000883332
AC connection busbars	3AXD50000887088	A-8-8-117	3AXD50000883349





1	2	3	4	5	6	7	8
<p>3AXD5000889037 HSFU GENERIC (ASSEMBLY)</p> <p style="font-size: small;">No errors all rights reserved and all the information contained herein is reproduction. All rights reserved. In third parties which require authority is strictly forbidden. © ABB Oy</p>							
<p style="text-align: center;">Initial Approval</p> <p style="text-align: center;">01-Mar-22 M. Michelsson</p>							
<h2>KITS FOR HSFU 2xBLHF IN GENERIC 2000x800x600 CABINET</h2> <p>Note! Only parts included in ABB kits are shown here. See assembly drawings for required Rittal and/or standard parts.</p>							
<p style="text-align: center;">HSFU AC CONN. BUSBARS W800 GEN KIT A-8-8-117 Ordering code: 3AXD5000883349</p>				<p style="text-align: center;">HSFU AC BUSBARS W800 GEN KIT A-8-8-115 Ordering code: 3AXD500088332</p>			
<p style="text-align: center;">HSFU MODULE INST. PARTS W800 GEN KIT A-8-8-338 Ordering code: 3AXD5000883318</p>				<p style="text-align: right;"> Based on: M. Michelsson 01-Mar-22 Title: ASSEMBLY DRAWING Customer: M. Koskinen 16-Feb-22 HIGH SPEED FILTER UNIT Project name: M. Asikainen 16-Feb-22 GENERIC W800 Weight: 3AXD5000889037 Weight kg </p>			
<p style="text-align: right;"> Doc. des.: ASSEMBLY DRAWING Scale: 1:25 A3 Rev. ind.: A.0 (DR) Form Doc. No.: 3AXD5000889037 Sheet Total </p>							



5

Electrical installation

Contents of this chapter

The wiring diagrams in this chapter are simplified presentations. For details, refer to the example circuit diagrams in the manual.

Note: The instructions do not cover all possible cabinet constructions.

Safety and liability

The installation must always be designed and made according to applicable local laws and regulations. ABB does not assume any liability whatsoever for any installation which breaches the local laws and/or other regulations. Furthermore, if the recommendations given by ABB are not followed, the drive system may experience problems that the warranty does not cover.



Electrical safety precautions

These electrical safety precautions are for all persons who do work on the drive, motor cable or motor.

This procedure gives information on how to de-energize the drive and make it safe to do work on it. The procedure does not include all possible drive configurations.



⚠ WARNING Obey these instructions. If you ignore them, injury or death, or damage to the equipment can occur. If you are not a qualified electrical professional, do not do electrical installation or maintenance work. Do these steps before you do installation or maintenance work.

1. Prepare for the work.
 - Make sure that you have a work order.
 - Do an on-site risk assessment or job hazard analysis.
 - Make sure that you have the correct tools available.
 - Make sure that the workers are qualified.
 - Select the correct personal protective equipment (PPE).
 - Stop the drive and motor(s).
2. Clearly identify the work location and equipment.
3. Disconnect all possible voltage sources. Make sure that connection is not possible. Lock out and tag out.
 - If the drive is equipped with a DC/DC converter unit or a DC feeder unit: Open the disconnecting device of the energy storage connected to the unit. The disconnecting device is outside the drive cabinet. Then open the DC switch-disconnector [Q11] of the unit.
 - Open the main disconnecting device of the drive
 - Open the DC switch-disconnectors [Q11] in the multidrives units if they are present.
 - Open the line-up charging switch [Q3] if it is present. Open also the unit charging switches [Q10] in the multidrives units if they are present.
 - Open the disconnecter of the supply transformer. (The main disconnecting device in the drive cabinet does not disconnect the voltage from the AC input power busbars of the drive cabinet.)
 - Open the auxiliary voltage switch-disconnector (if it is present), and all other possible disconnecting devices that isolate the drive from dangerous voltage sources.
 - If there is a permanent magnet motor connected to the drive, disconnect the motor from the drive with a safety switch or by other means.
 - Open the main isolating device of the drive.
 - Disconnect all dangerous external voltages from the control circuits.
 - After you disconnect power from the drive, wait 5 minutes to let the intermediate circuit capacitors discharge before you continue.
4. Protect other energized parts in the work location against contact and take special precautions when close to bare conductors.
5. Measure that the installation is de-energized. Use a high-quality voltage tester. If the measurement requires that you remove shrouding or other cabinet structures,

obey the local laws and regulations applicable to live electrical work. This includes, but is not limited to, electric shock and arc protection.

- Before and after you measure the installation, verify the operation of the voltage tester on a known voltage source.
- Make sure that the voltage between the input power terminals of the drive (L1, L2, L3) and the grounding (PE) busbar is zero.
- Make sure that the voltage between the output power terminals of the drive (U, V, W) and the grounding (PE) busbar is zero.

Important! Repeat the measurement with the DC voltage setting of the voltage tester. Measure between each phase and ground. There is a risk of dangerous DC voltage charging due to leakage capacitances of the motor circuit. This voltage can remain charged for a long time after the drive power-off. The measurement discharges the voltage.

- Make sure that the voltage between the drive DC busbars and the grounding (PE) busbar is zero.
 - If the drive is equipped with a DC/DC converter unit or a DC feeder unit: Make sure that the voltage between the energy storage terminals of the unit (ES+ and ES-) and the grounding (PE) busbar is zero.
6. Install temporary grounding as required by the local regulations.
 7. Ask for a permit to work from the person that is responsible for the electrical installation work.

General notes

■ Printed circuit boards

NOTICE Use an antistatic wrist strap when you handle printed circuit boards. Do not touch the boards unnecessarily. The boards are sensitive to electrostatic discharge.

■ Handling fiber-optic cables

NOTICE Obey these instructions. If you ignore them, equipment malfunction and damage to the fiber-optic cables can occur.

- Handle the fiber-optic cables with care.
 - When you disconnect the cables, always hold the connector, not the cable itself.
 - Do not touch the ends of the optical fibers with bare hands, because the ends are very sensitive to dirt.
 - Do not bend the fiber-optic cables too tightly. The minimum permitted bend radius is 35 mm (1.4 in).
-

Measuring the insulation

■ Measuring the insulation resistance of the drive

NOTICE Do not do voltage withstand or insulation resistance tests on the drive. The tests can cause damage to the drive. Every drive is tested for insulation between the main circuit and the chassis at the factory. Also, there are voltage-limiting circuits inside the drive which cut down the testing voltage automatically.



■ Measuring the insulation resistance of the motor and motor cable



▲WARNING Obey the safety instructions of the drive. If you ignore them, injury or death, or damage to the equipment can occur. If you are not a qualified electrical professional, do not do electrical installation, commissioning or maintenance work.

1. Do the steps in [Electrical safety precautions \(page 180\)](#) before you start the work.
2. Make sure that the motor cable is disconnected from the drive output terminals.
3. Measure the insulation resistance between each phase conductor and the protective earth conductor. Use a measuring voltage of 1000 V DC. The insulation resistance of an ABB motor must be more than 100 Mohm (reference value at 25 °C [77 °F]). For the insulation resistance of other motors, refer to the manufacturer's instructions.

Note: Moisture inside the motor reduces the insulation resistance. If you think that there is moisture in the motor, dry the motor and do the measurement again.

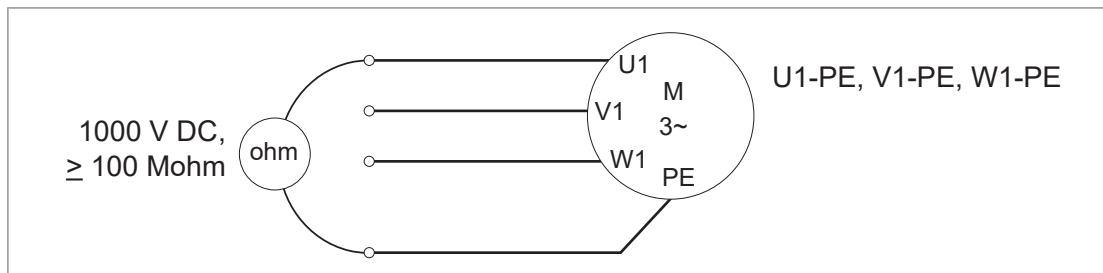

■ Brake resistor assembly

Refer to section [Checking the insulation of the brake resistor assembly \(page 419\)](#).

Power connections – Frames R1i...R5i

A simplified diagram of the power connections is presented below.

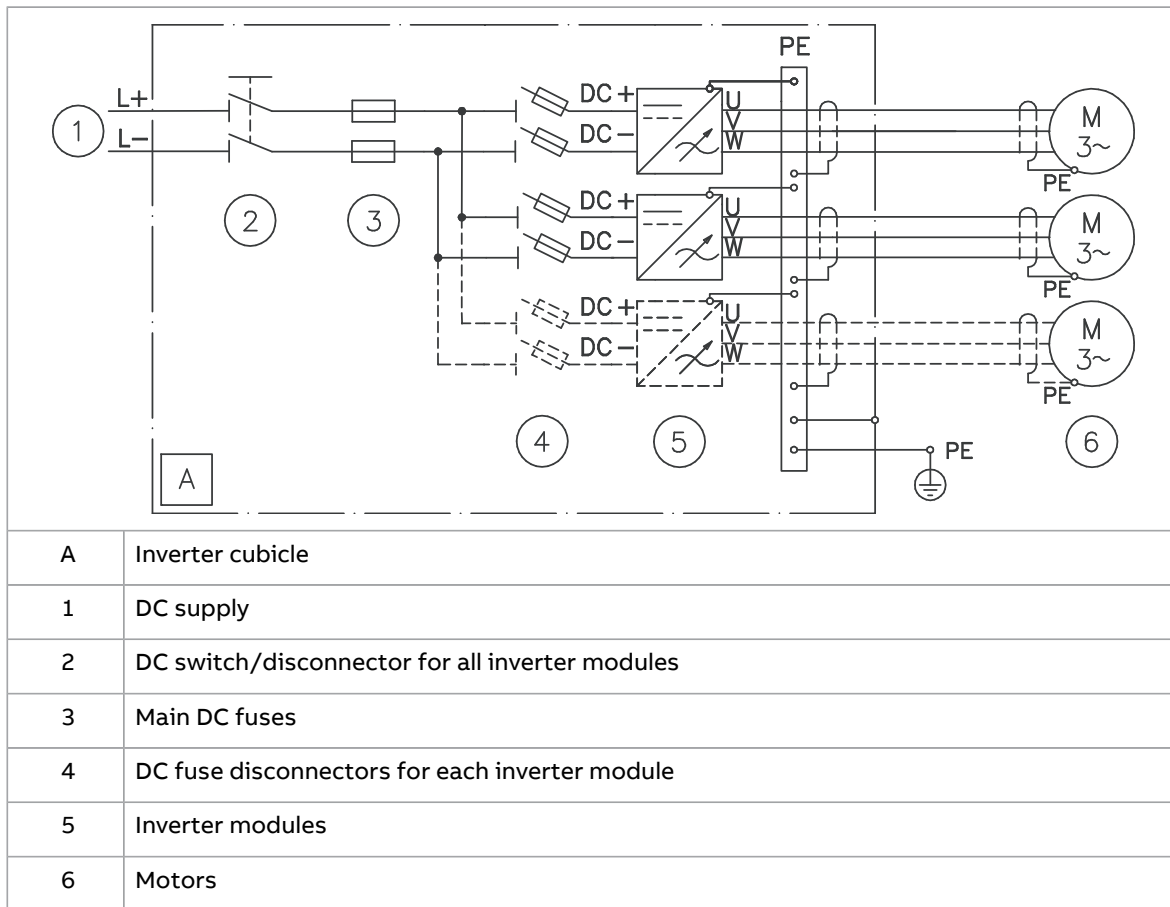

■ Connection procedure

Frames R1i...R4i: On IT (ungrounded) systems and corner-grounded TN systems, remove the varistor screw (if present) from the inverter module. The screw is labelled VAR and it is located close to the power terminals.

Frames R1i and R2i



▲WARNING Obey the safety instructions of the drive. If you ignore them, injury or death, or damage to the equipment can occur. If you are not a qualified electrical professional, do not do installation, commissioning, or maintenance work.

1. Run the output (motor) cable into the cubicle through a cable gland or grommet. In case a grounding cable gland is available, remove the outer jacket of the cable where it passes through the cable gland.
2. Cut the input (DC) and output cables to suitable length and strip the ends of the individual conductors.
3. Twist the shield strands of the output cable together to form a separate conductor and crimp a ring terminal onto it. Do the same for the input cable if it is a shielded type.

4. Connect the conductors to the terminal blocks. Connect the cable shields to grounding terminals near the terminal blocks.
5. Secure the cables inside and outside the cabinet mechanically.
6. Tighten the cable gland if present.
7. Connect the motor cable.

Frames R3i...R5i

1. Run the output (motor) cable into the cubicle through a cable gland or grommet. 360° grounding of the cable shield is recommended to suppress interference. In case a grounding cable gland is available, remove the outer jacket of the cable where it passes through the cable gland.
2. Remove the shrouds covering the terminals of the inverter module.
3. Cut the input (DC) and output cables to suitable length and strip the ends of the individual conductors.
4. Twist the shield strands of the output cable together to form a separate conductor. Crimp a suitable ring terminal onto the end, and cover the remaining bare screen with tape as shown below. Do the same for the input cable if it is a shielded type.

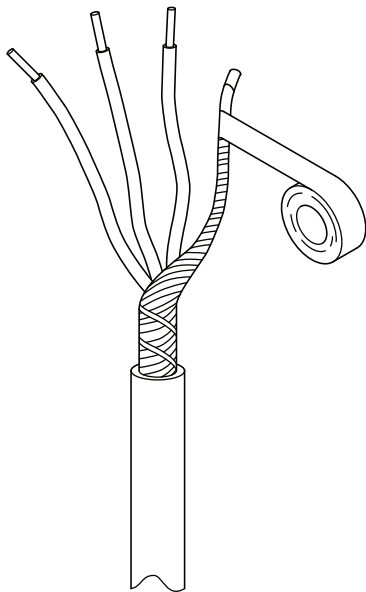

5. Insert the conductors to the terminals and tighten the Allen screw. Note that the original screw lugs can be replaced by crimp ring terminals connected directly to the connection post. Make note of the order and orientation of the washers on the connection post.
 6. Connect the cable shields to ground near the terminals.
 7. Reinstall the terminal covers.
 8. Secure the cables inside and outside the cabinet mechanically.
 9. Tighten the cable gland if present.
 10. Connect the motor cable.
-

Power connections – Frames R6i...R8i

Simplified diagrams of the power connections are presented below.

■ R6i inverter module

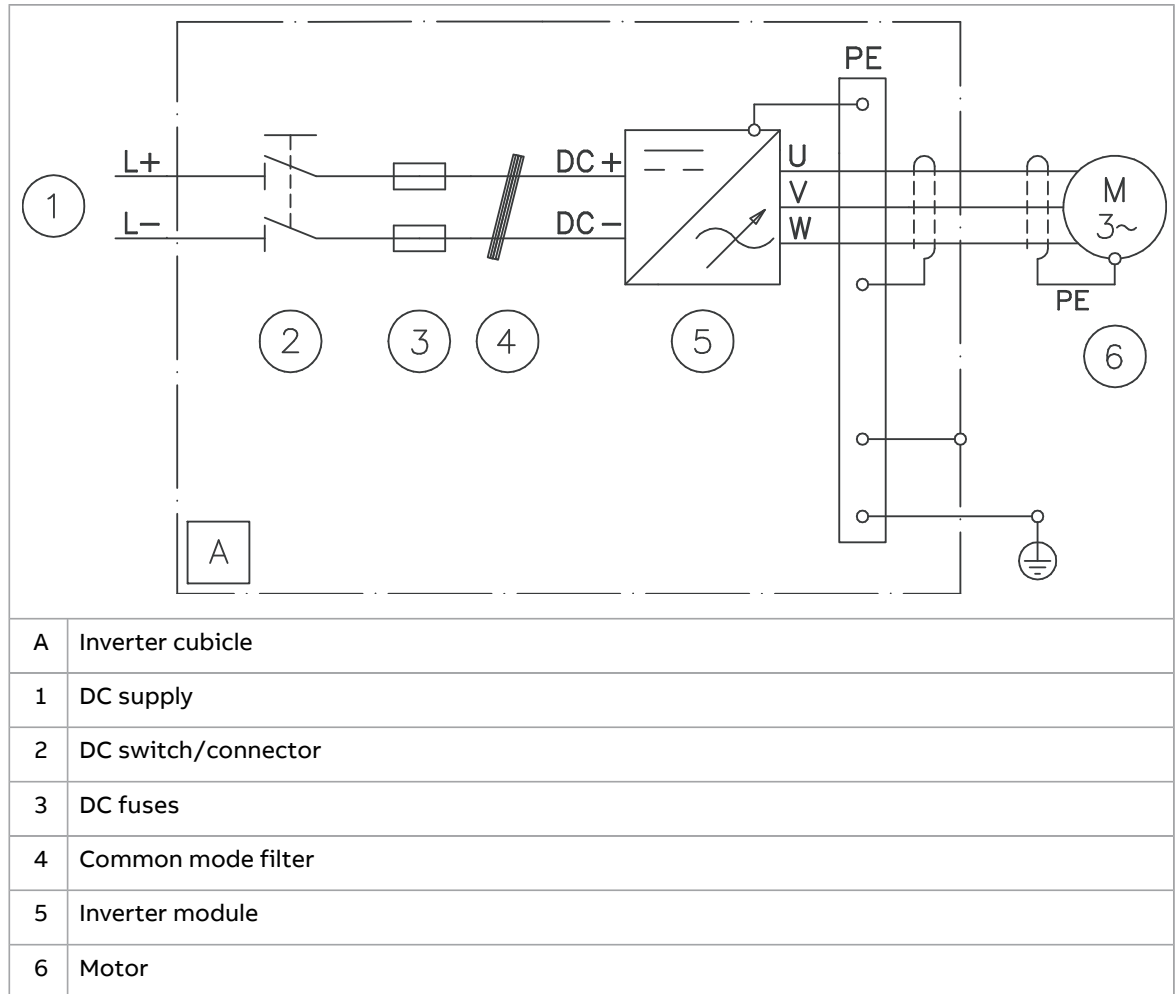

■ R7i inverter module

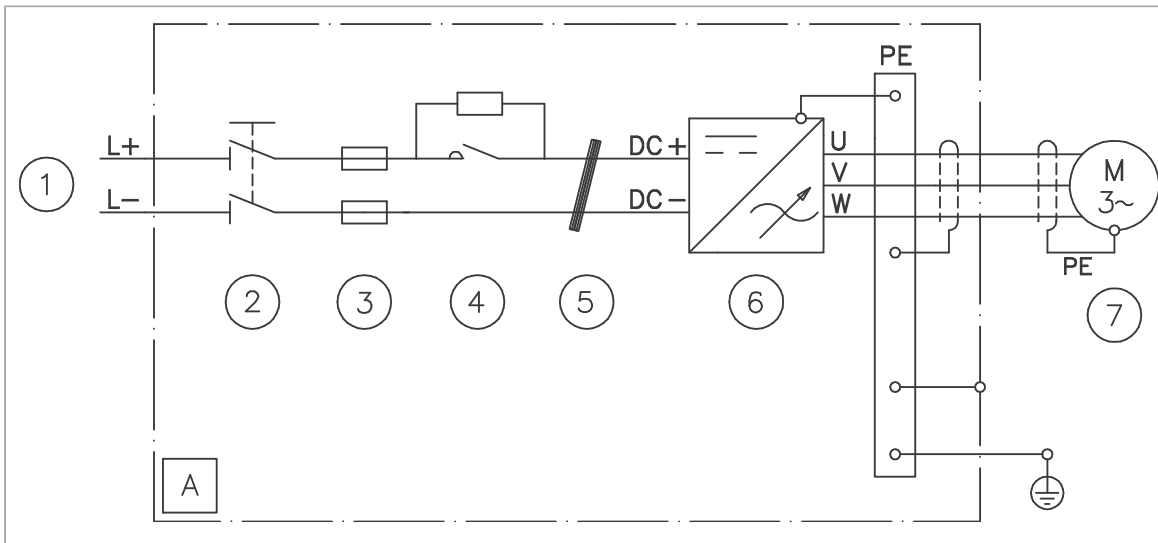

A	Inverter cubicle
1	DC supply
2	DC switch/connector
3	DC fuses
4	Unit charging circuit (contactor and resistors)
5	Common mode filter
6	Inverter module
7	Motor



■ R8i inverter module

R8i inverter module

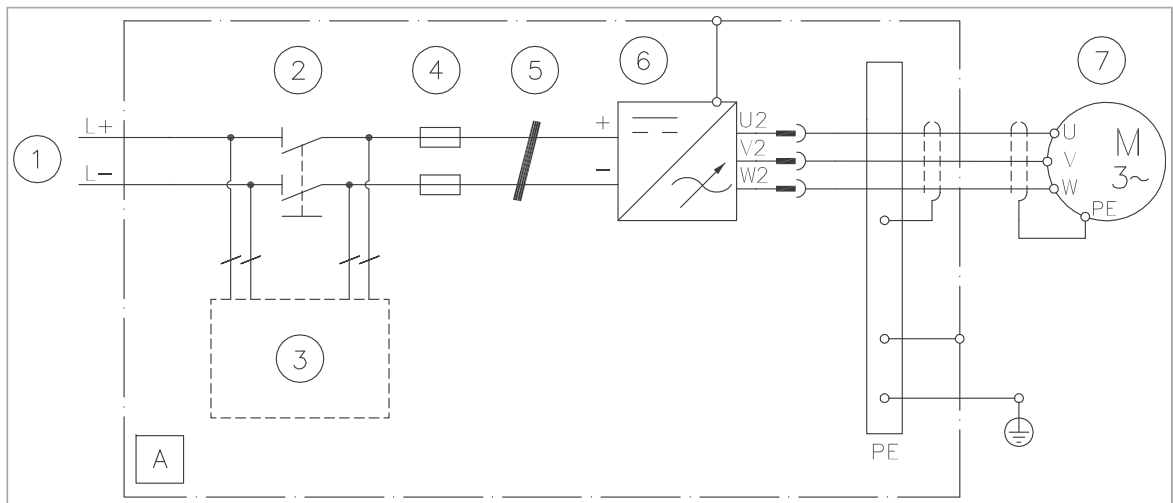

A	Inverter cubicle
1	DC supply
2	DC switch-disconnector
3	Unit charging circuit (fuses, resistors, charging controller)
4	DC fuses
5	Common mode filter
6	Inverter module
7	Motor



2×R8i inverter unit

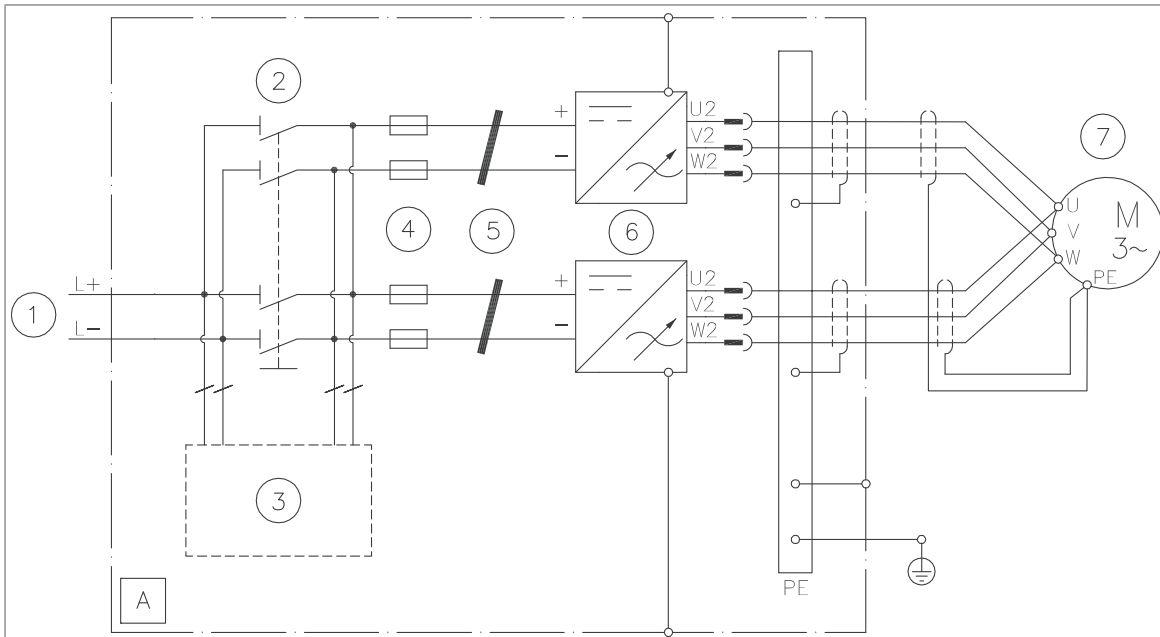

A	Inverter cubicle
1	DC supply
2	DC switch-disconnector
3	Unit charging circuit (fuses, resistors, charging controller)
4	DC fuses
5	Common mode filters
6	Inverter modules
7	Motor



■ Connection procedure



▲WARNING Obey the safety instructions of the drive. If you ignore them, injury or death, or damage to the equipment can occur. If you are not a qualified electrical professional, do not do installation, commissioning, or maintenance work.

1. Stop the drive and do the steps in [Electrical safety precautions \(page 180\)](#) before you start the work.
2. Ground the inverter modules by the top edge of the front plate. The grounding point is marked on the module. Connect the front plate to the frame support bracket with screws. The bracket should have a galvanic connection to the PE busbar through the cabinet frame.

Note:

- If the cabinet frame is painted (such as with Rittal enclosures), it is important to make sure that a good galvanic connection to ground (PE busbar) is achieved. You can, for example, remove the paint from the connection points and use star washers.
- The connection to ground merely through the mounting screws and the cabinet chassis is not always good enough. To ensure the continuity of the protective bonding circuit, you can connect the modules to the cabinet PE busbar with a copper busbar or cable. The inductance and impedance of the PE conductor must be rated according to permissible touch voltage appearing under fault conditions (so that the fault point voltage will not rise excessively when a ground fault occurs).

See [ACS880 multidrives cabinets and modules electrical planning instructions \(3AUA0000102324 \[English\]\)](#).

3. Do the connections between the components inside the cabinet (if not yet done).
4. Put the output (motor) cable into the cubicle through a cable gland or grommet. Ground the cable shield 360° to suppress interference. In case a grounding cable gland is available, remove the outer jacket of the cable where it passes through the cable gland, refer to [Cable entry kit \(page 339\)](#).
5. Cut the output cable to suitable length and strip the ends of the individual conductors.



- Twist the shield strands of the output cable together to form a separate conductor and wrap tape around it as shown.

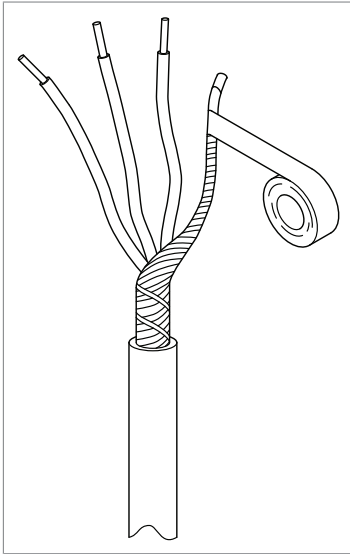

- Crimp suitable cable lugs to the conductors as well as the twisted shield. Connect the phase conductors to the output busbars. Connect the cable shield to a PE busbar.
- Secure the cables inside and outside the cabinet mechanically.
- Tighten the cable gland if present.



Grounding the motor cable shield at the motor end

For minimum radio-frequency interference, ground the cable shield 360° at the cable entry of the motor terminal box.

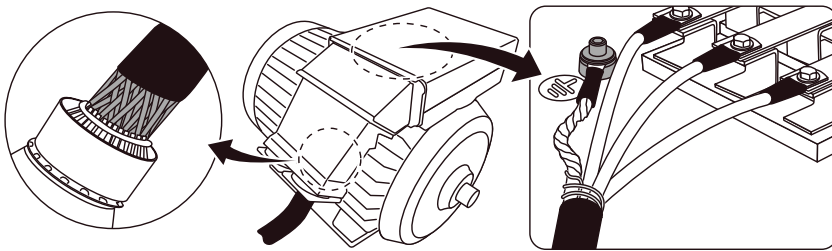

■ Installing the BLHF filter

Remove the fan of the BLHF filter module. For instructions, see [ACS880 multidrive for high-speed test benches supplement \(3AXD50000818013 \[English\]\)](#). Push the BLHF filter module into its place. Connect the filter AC busbars (behind the filter module) with six bolts to the busbars on the cabinet frame. Reinstall the fan of the BLHF filter module.

Bottom connection of the BLHF filter

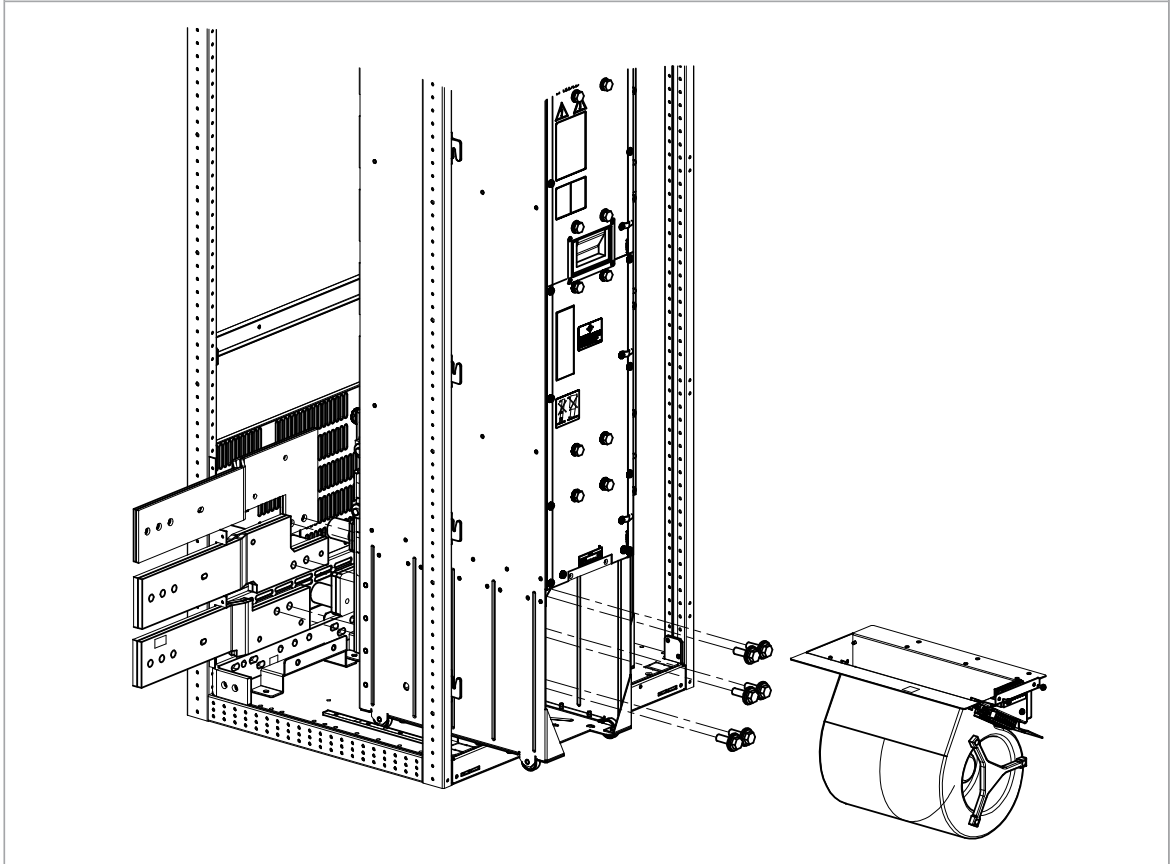

Top connection of the 1×BLHF filter

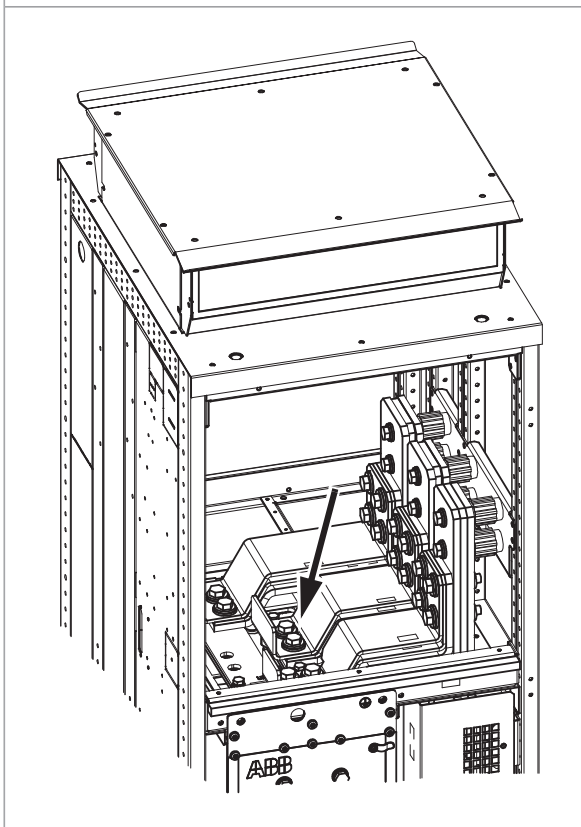

Top connection of the 2×BLHF filter

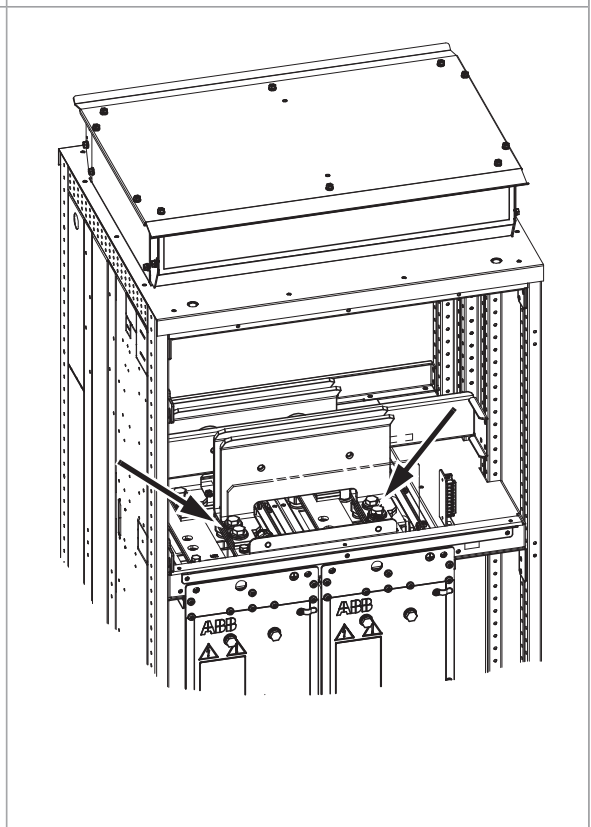

Replacing ACS800 R8i modules with ACS880 R8i modules

ACS880 R8i modules can be ordered with option +P942 for mechanical compatibility with ACS800 R8i modules. A dimension drawing is presented on [Frame R8i with option +P942 \(page 437\)](#).

The following procedure explains the additional wiring changes that are required.



⚠ WARNING Obey the safety instructions of the drive. If you ignore them, injury or death, or damage to the equipment can occur. If you are not a qualified electrical professional, do not do installation, commissioning, or maintenance work.

1. Replace the inverter module(s).

Note: The DC fuses (F11.xx) and common mode filters (R11.xx) at the input of each inverter module need not be changed if the output currents of the inverter module(s) remain unchanged.

2. If needed, connect an auxiliary voltage supply of 230 V AC 50 Hz (standard) or 115 V AC 60 Hz (with option +G304) to X50:4...5 on the module to power the BDPS (internal power supply of the module) even when the DC link is not live.
3. Replace the RDCU control unit with an UCU-22...24 inverter control unit with a sufficient number of inverter module connections. Connect the control unit to a 24 V DC power supply. (ABB recommends an external power supply for an inverter unit consisting of parallel-connected modules; with a single-module configuration, connectors X53:1 and X53:2 on the module can be used.)
4. Connect the UCU-22...24 control unit to the inverter module(s) using fiber optic cables. In case of parallel-connected modules, remove the existing APBU branching unit.
5. If the module is equipped with option +C188 (direct-on-line cooling fan), connect a 3-phase 400 V 50/60 Hz (or 320 V 60 Hz) supply to X50:1...3.
6. If the inverter unit is equipped with a DC switch/disconnector and charging controller, connect terminals V50 and V60 of the inverter module to the charging controller using fiber optic cables.

Note: With an ACS880 R8i module used with the ACS800 charging circuit, only one charging cycle in five minutes is allowed.

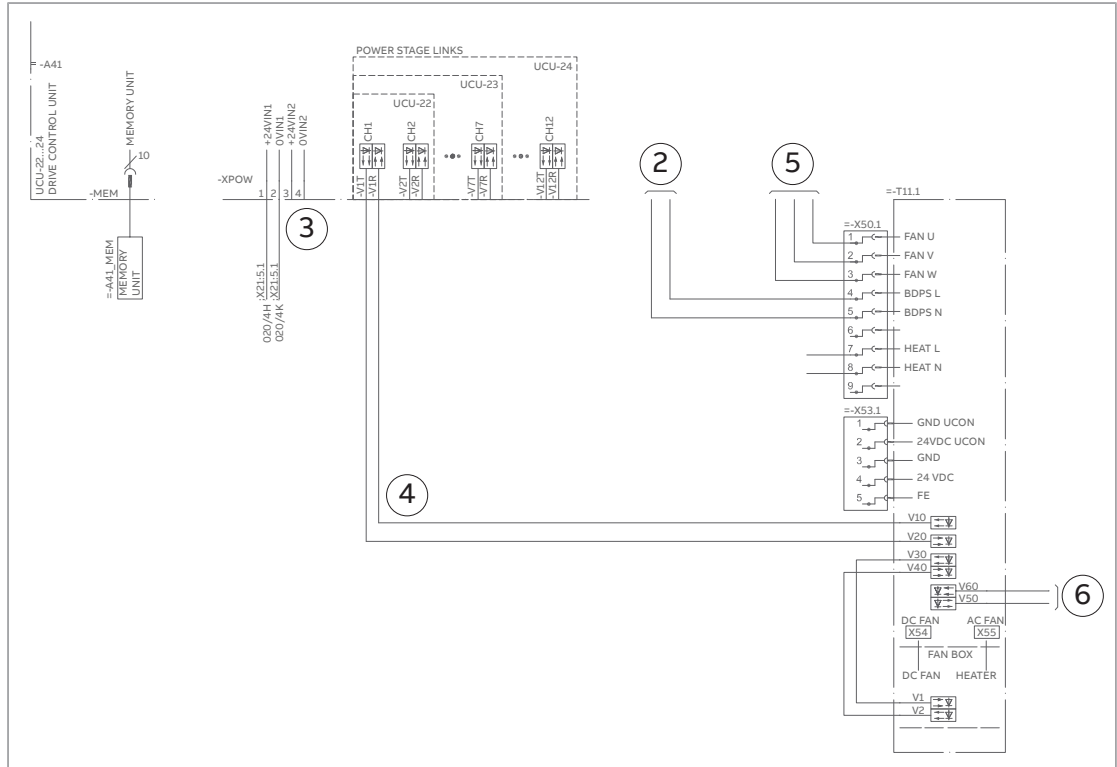

7. On the UCU-22...24 control unit, connect the DIIL input to a +24VD terminal.

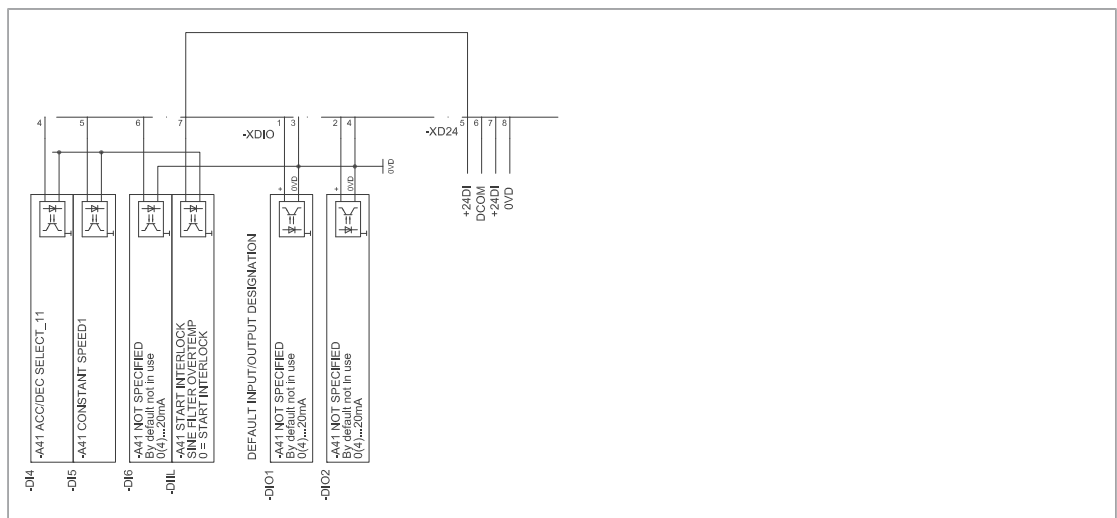

8. If the Safe torque off (STO) function is to be used, remove the jumper connection between X52 and X53 on each module. Wire the STO link to all inverter modules of the inverter unit. Connect the device triggering the STO function to the UCU-22...24 control unit. Refer to [The Safe torque off function \(page 389\)](#).

9. Connect an ACS-AP-x control panel to XPAN on the UCU-22...24 control unit.

194 Electrical installation

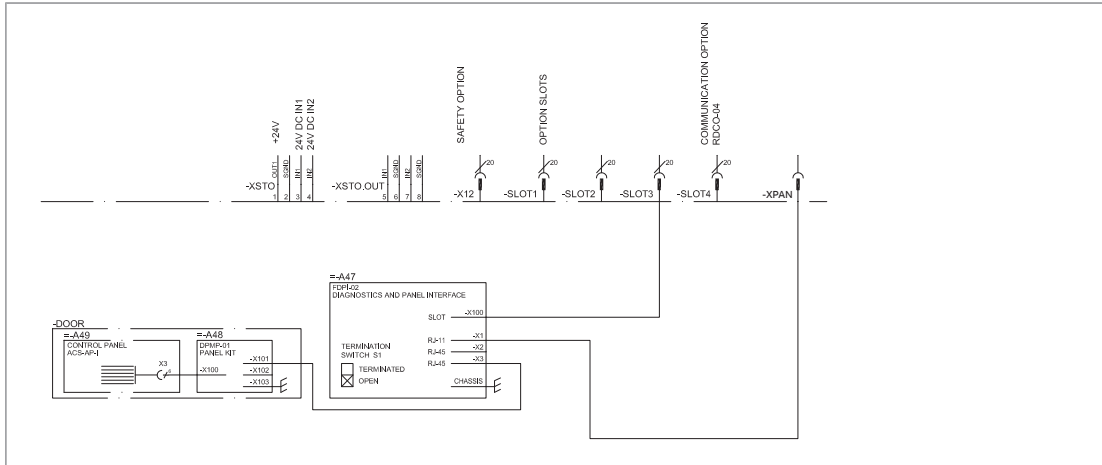

10. If the modules are equipped with option +C183 (heating elements), connect a 230/115 V AC (50/60 Hz) supply to X50:7...8.

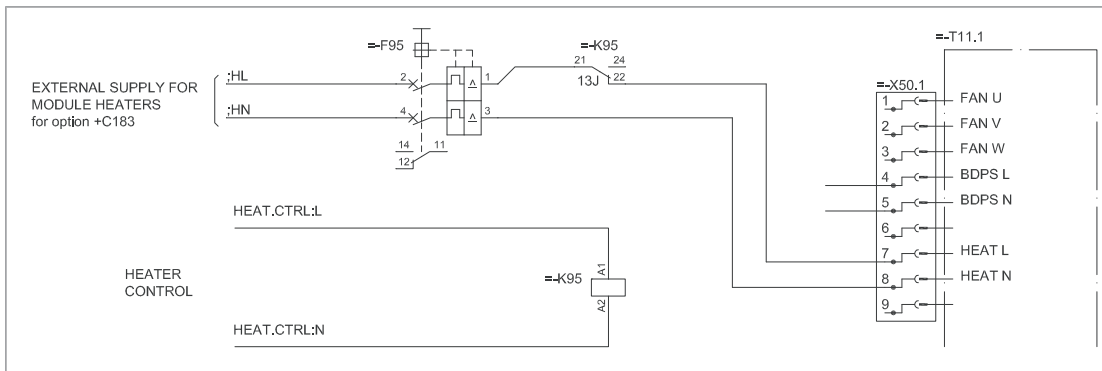

Connecting the control cables

For the default control connections, refer to the default control connections diagram of the applicable control unit.



⚠ WARNING Obey the safety instructions of the drive. If you ignore them, injury or death, or damage to the equipment can occur. If you are not a qualified electrical professional, do not do installation, commissioning, or maintenance work.

1. Stop the drive and do the steps in [Electrical safety precautions \(page 180\)](#) before you start the work.
2. Remove shrouding to access the cable entries and trunking inside the cubicle.
3. Run the control cables into the cubicle. If possible, arrange for a 360° grounding of the cable shield at the cable entry.

If the outer surface of the shield is non-conductive, turn the shield inside out as shown below and wrap copper foil around the cable to keep the shielding continuous. Do not cut the grounding wire (if present).

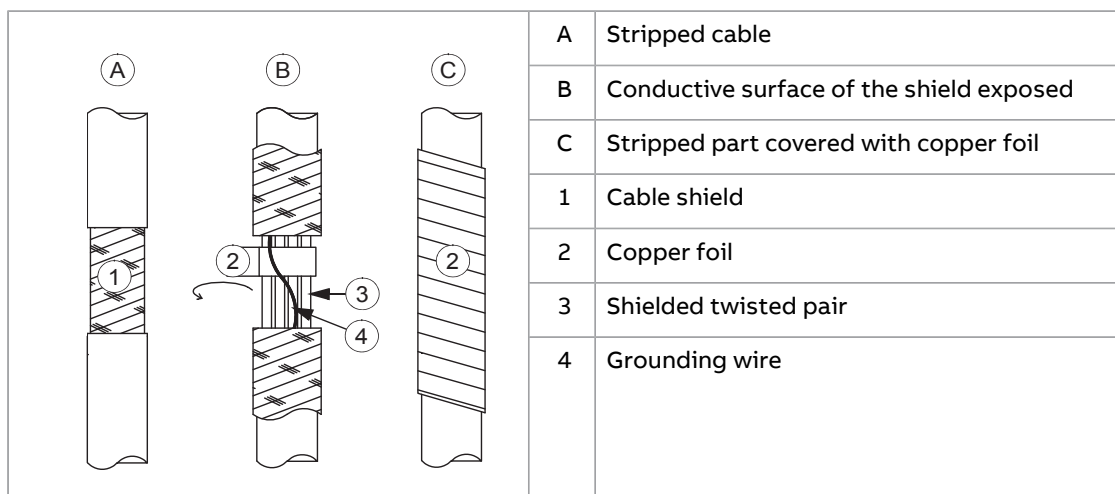

4. Run the cables to the control unit (or other connection point). Use the existing trunking wherever possible.
5. (Only when running the cable to the inverter module) The inverter control units have a clamp plate attached. Remove the outer sheathing of the cable at one of the clamps on the plate. Tighten the clamp onto the bare cable shield.
6. Cut the cables to suitable length.

7. Strip the cable ends and conductors. When connecting to the drive I/O, also remove the shield along with the outer sheathing, and use electrical tape or shrink tubing to contain the strands. Elsewhere, twist the outer shield strands into a bundle, crimp a lug onto it and connect it to the nearest chassis grounding point.

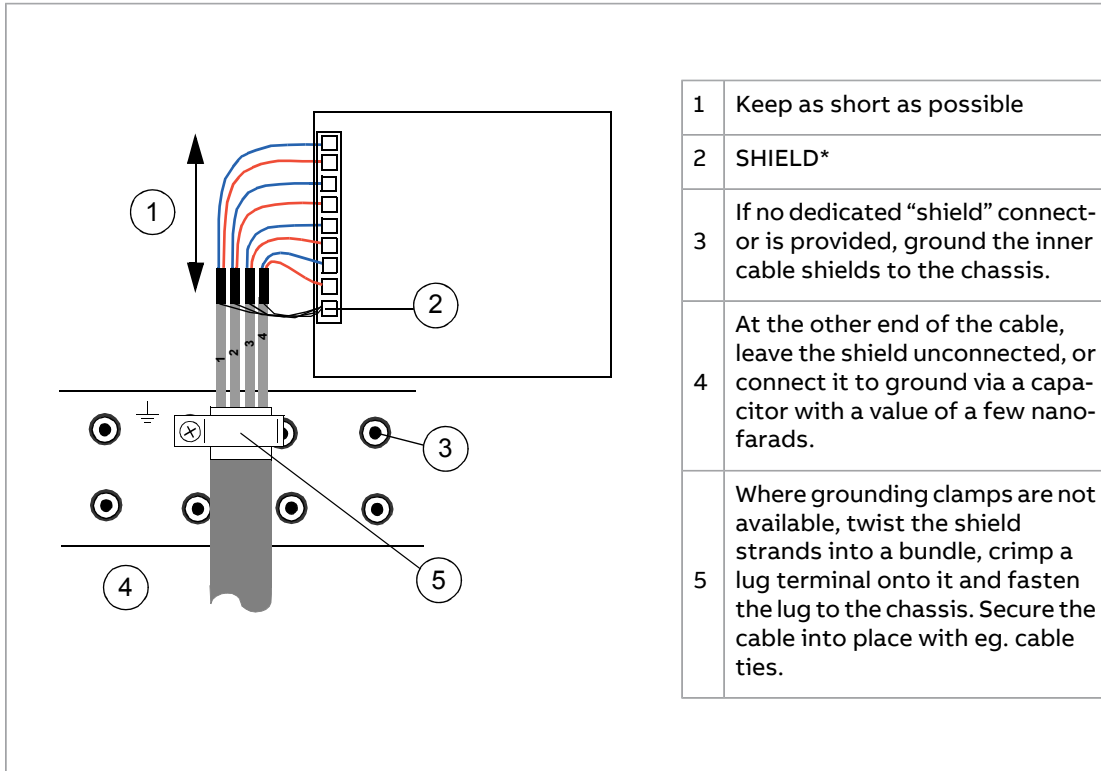

8. Connect the conductors to appropriate terminals.
9. Install any shrouds removed earlier.

Installing option modules

■ Installing an I/O extension, fieldbus adapter or pulse encoder option module

Refer to the option module manual. For installation onto the UCU-22, UCU-23 or UCU-24 control unit, refer to [UCU-22, -23 and -24 control units hardware manual \(3AXD50000817726 \[English\]\)](#). For installation onto the BCU-02, BCU-12 or BCU-22 control unit, refer to [BCU-02, -12 and -22 control units Hardware manual \(3AUA0000113605 \[English\]\)](#).

■ Installing an FSO safety functions module onto UCU-22, UCU-23 or UCU-24 or BCU control unit

Refer to [FSO-12 safety functions module user's manual](#) or [FSO-21 safety functions module user's manual](#). For installation on the UCU-22, UCU-23 or UCU-24 control unit, refer to [UCU-22, -23 and -24 control units hardware manual \(3AXD50000817726 \[English\]\)](#). If you install the module onto BCU-02, BCU-12 or BCU-22 control unit, refer to [BCU-02, -12 and -22 control units Hardware manual \(3AUA0000113605 \[English\]\)](#).

■ Installing an FSO safety functions module onto ZCU control unit



▲WARNING Obey the safety instructions of the drive. If you ignore them, injury or death, or damage to the equipment can occur. If you are not a qualified electrical professional, do not do electrical installation, commissioning or maintenance work.

NOTICE Use an ESD wristband when you handle printed circuit boards. Do not touch the printed circuit boards unnecessarily. They are sensitive to electrostatic discharge.

1. Stop the drive and do the steps in [Electrical safety precautions \(page 180\)](#) before you start the work.
2. The FSO module comes with alternative bottom plates for mounting on different control units. Replace the bottom plate of the FSO module if necessary.
3. Connect the data cable to control unit connector X12.
4. Put the FSO module into its position on SLOT 2 of the control unit. Attach the FSO module by the bottom plate with four screws.
5. Torque the FSO module electronics grounding screw to 1.2 N·m (10.6 lbf·in).
Note: The screw tightens the connections and grounds the FSO module. It is essential for fulfilling the EMC requirements and for proper operation of the FSO module.
6. Connect the other end of the data cable to connector X110 on the FSO module.
7. Connect the STO cable to FSO module connector X111 and to control unit connector XSTO.
8. Connect the power supply wires to the FSO module terminal X112.
9. Connect any user-defined signal cables to the FSO module according to the application requirements. Refer to the FSO module user's manual.



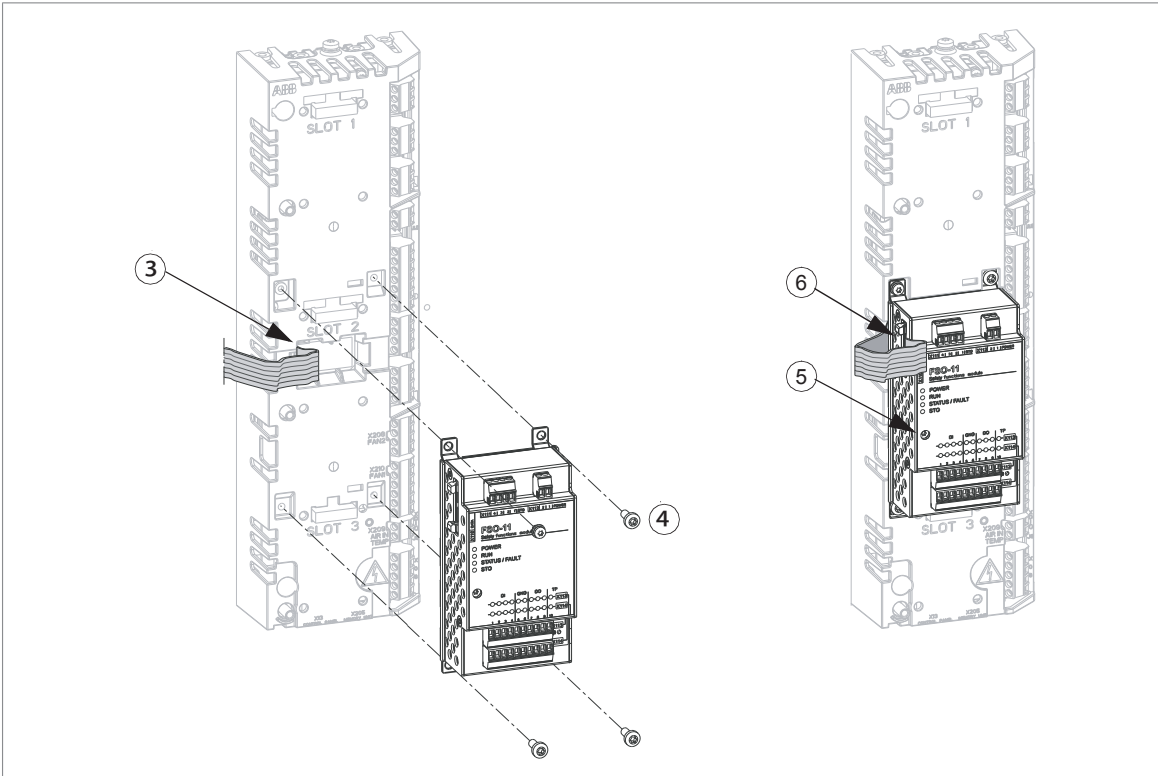

■ Mounting kit for FSO safety functions module

To reserve the slots of the control unit for other modules, you can install the FSO module separately from the control unit using mounting kit 3AXD50000025495 (A-X-X-279). The kit contains:

- parts for mounting the FSO module onto a DIN rail nearby the control unit
- parts for mounting the FSO module onto the grounding/clamping plate of a ZCU-14 control unit
- longer cables for connecting the FSO module to the control unit
- installation instructions (assembly drawing).

The illustration below shows the FSO module installed onto a DIN rail.

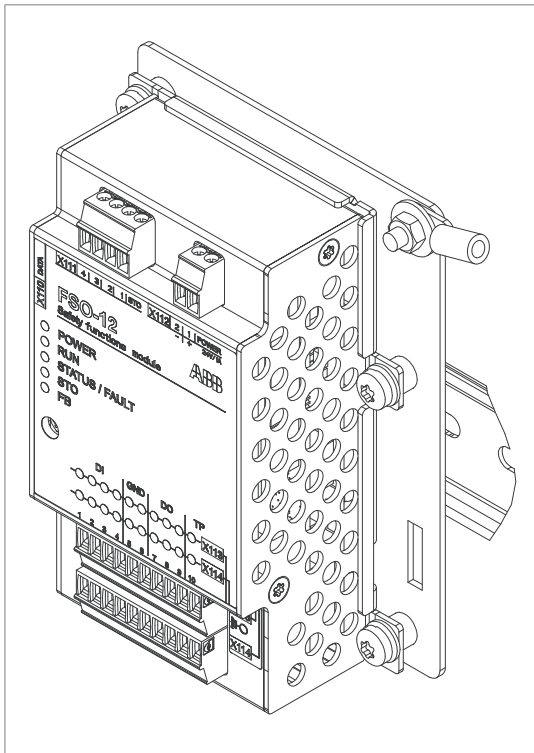

■ Installing the FSPS-21 PROFIsafe safety functions module

To install the FSPS-21 PROFIsafe safety functions module onto the drive control unit, refer to [FSPS-21 PROFIsafe safety functions module user's manual \(3AXD50000158638 \[English\]\)](#).

■ Installing the FSCS-21 CIP Safety™ functions module

To install the FSCS-21 CIP Safety™ functions module onto the drive control unit, refer to [FSCS-21 CIP Safety™ functions module user's manual \(3AXD50001065478 \[English\]\)](#).

Connecting a PC

NOTICE Do not connect a PC directly to the control panel connector of the control unit. It can cause damage.

To connect a control panel to a PC (with, for example, Drive Composer PC tool):

1. Put the control panel into the panel holder or platform.
2. Remove the USB connector cover on the front of the control panel.
3. Connect a USB cable (Type A to Type Mini-B) between the USB connector on the control panel (3a) and a free USB port on the PC (3b).
4. The panel shows when the connection is active.
5. Refer to the documentation of the PC tool for setup instructions.

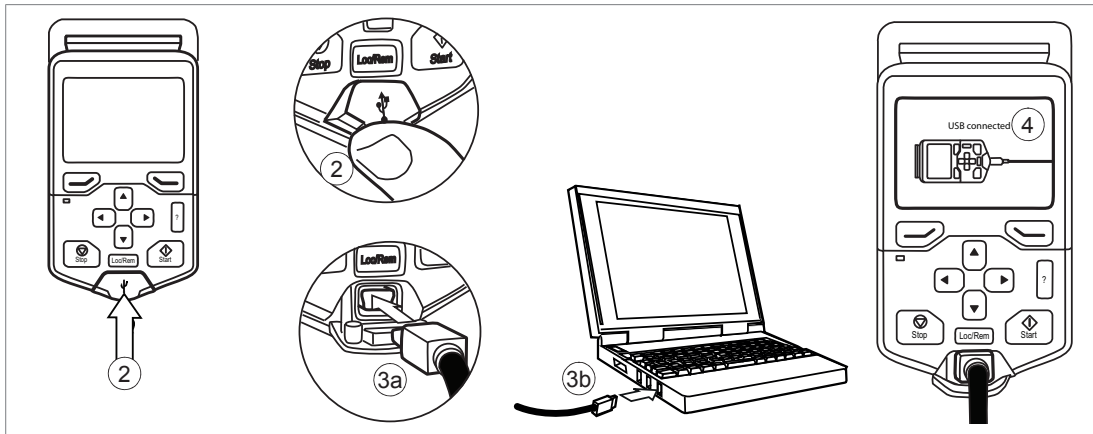

Alternatively, you can connect an Ethernet cable (for example, Cat 5e) to the Ethernet port behind the control panel. Make sure that the control panel is on a platform or a DIN rail.

Panel bus (control of several units from one control panel)

One control panel (or PC) can be used to control several drives (or inverter units, supply units etc.) by constructing a panel bus. This is done by daisy-chaining the panel connections of the drives. Some drives have the necessary (twin) panel connectors in the control panel holder; those that do not, require the installation of an FDPI-02 module (available separately). For further information, refer to the hardware description and [FDPI-02 diagnostics and panel interface user's manual \(3AUA0000113618 \[English\]\)](#).

The maximum allowed length of the cable chain is 100 m (328 ft).

Do the steps in [Electrical safety precautions \(page 180\)](#) before you start the work.

1. Connect the panel to one drive using an Ethernet (for example Cat 5e) cable.
 - Use Menu - Settings - Edit texts - Drive to give a descriptive name to the drive
 - Use parameter 49.01* to assign the drive with a unique node ID number
 - Set other parameters in group 49* if necessary
 - Use parameter 49.06* to validate any changes.

*The parameter group is 149 with supply (line-side), brake or DC/DC converter units.

Repeat the above for each drive.

2. With the panel connected to one unit, link the units using Ethernet cables.
3. Switch on the bus termination on the drive that is farthest from the control panel in the chain.
 - With drives that have the panel mounted on the front cover, move the terminating switch into the outer position.
 - With the FDPI-02 module and BCU-02 control unit: move termination switch S1 on the FDPI-02 module into the TERMINATED position.
 - With the FDPI-02 module and UCU-22...24 control unit: move termination switch S1 on the FDPI-02 module into the OPEN position. Move control panel connection termination switch XPAN TERM on the UCU-22...24 control unit to ON position.

Make sure that bus termination is off on all other drives.

4. On the control panel, switch on the panel bus functionality (Options - Select drive - Panel bus). The drive to be controlled can now be selected from the list under Options - Select drive.

■ Twin panel connection

If a PC is connected to the control panel, the drives on the panel bus are automatically displayed in the Drive Composer PC tool.

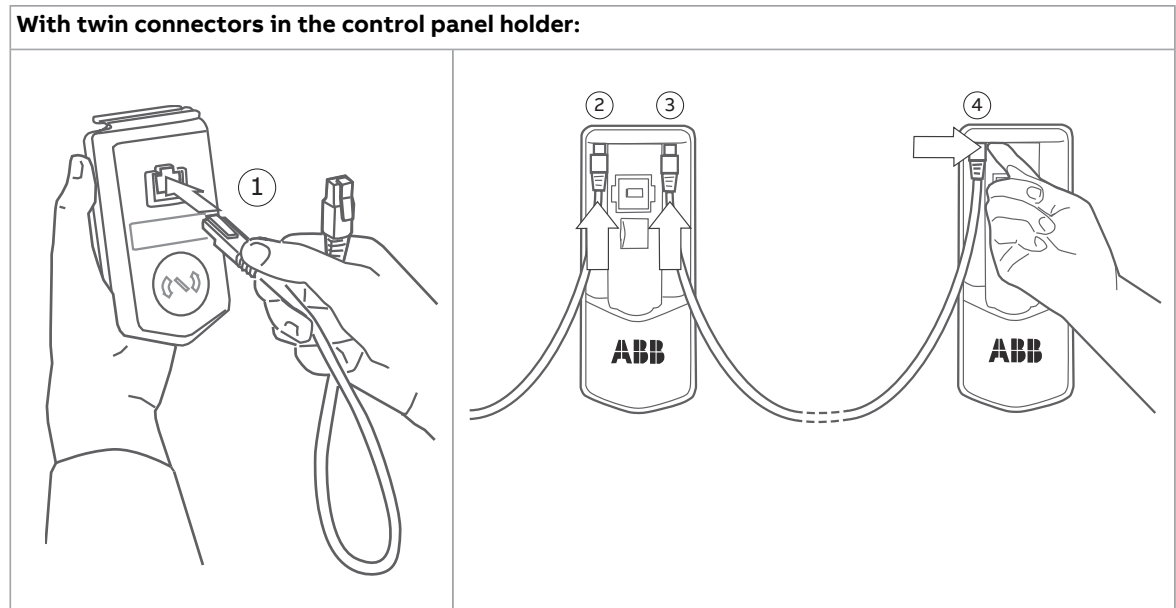

■ Connection with FDPI-02 modules

Refer to [FDPI-02 diagnostics and panel interface user's manual \(3AUA0000113618 \[English\]\)](#).



A large, light gray square with rounded corners, centered on the page. Inside the square is a large, bold, black number '6'.

UCU-22, UCU-23 and UCU-24 control units

Contents of this chapter

This chapter

- gives information on the connections of the control unit, and
- has the specifications of the inputs and outputs of the control unit.

General

The UCU-22...24 control units are used for controlling power modules (drive, inverter, supply, converter, etc) via fiber optic links. UCU-22 has two, UCU-23 has eight and UCU-24 has 14 power module connections. The UCU-22...24 control units have integrated branching unit functionality for collecting and storing real-time data from the power modules to help fault tracing and analysis. The data is stored on a memory card which can be analyzed by ABB service personnel.

Layout

The figures below show the layout of the UCU-24 control unit.

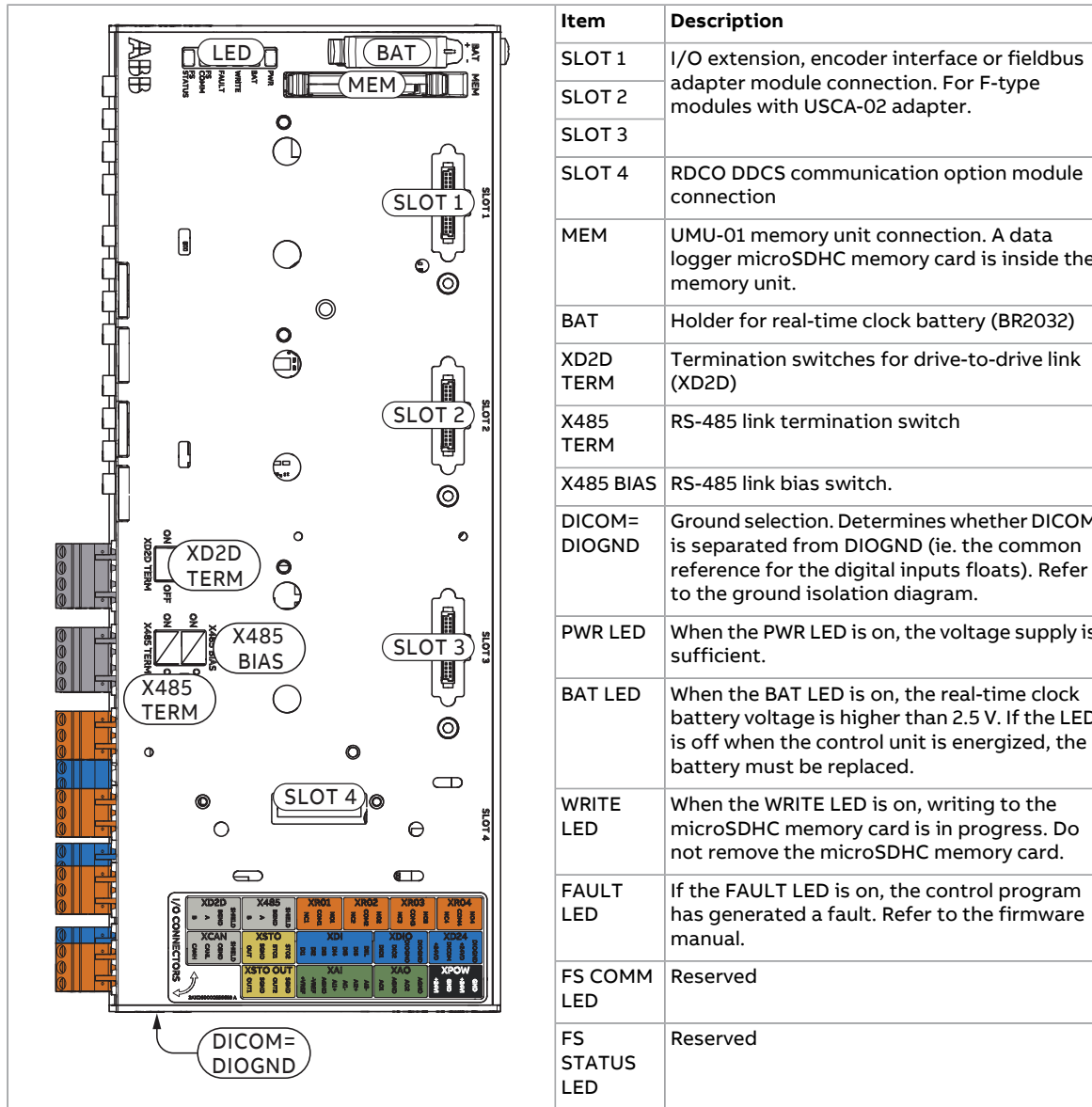

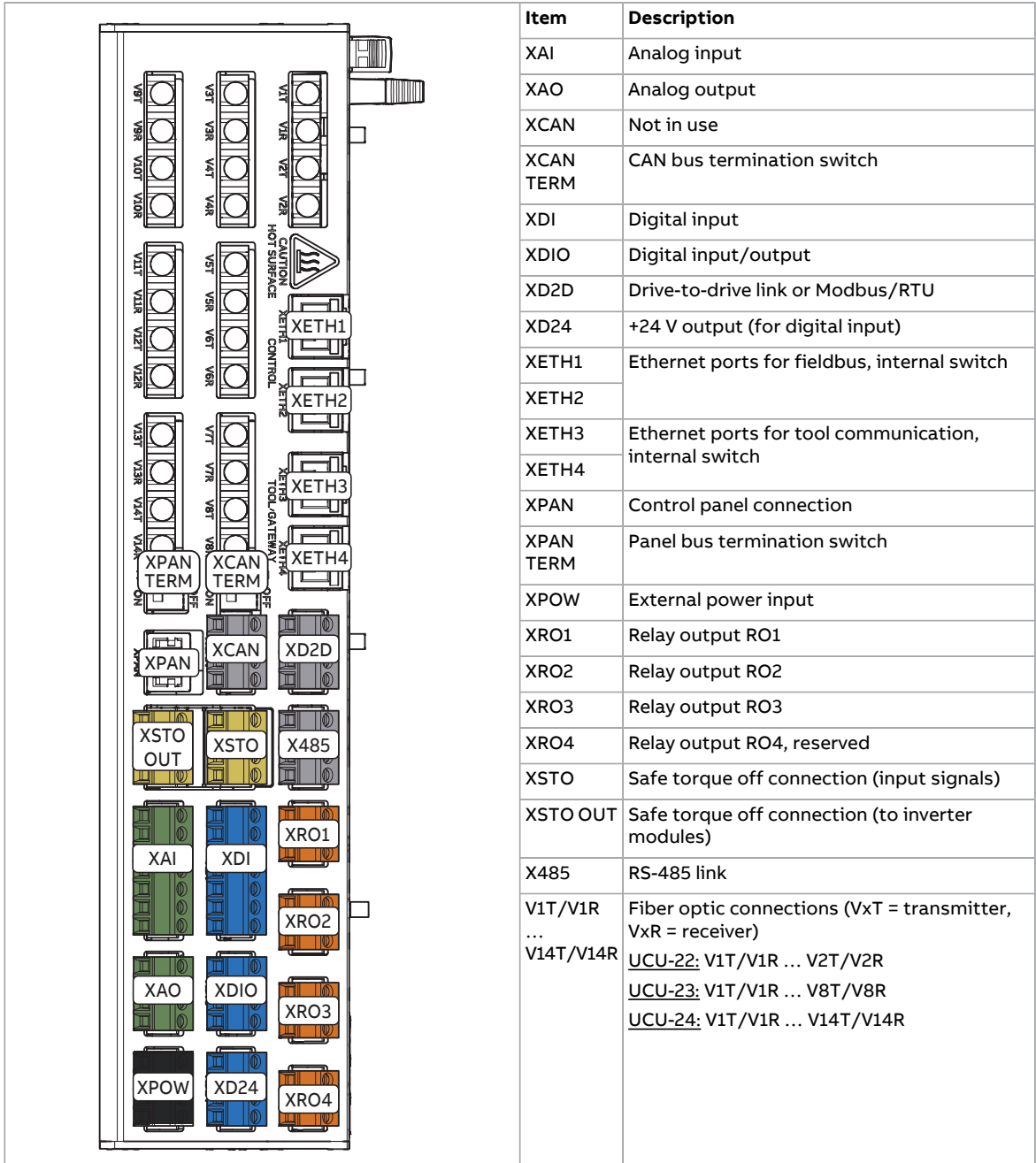

206 UCU-22, UCU-23 and UCU-24 control units



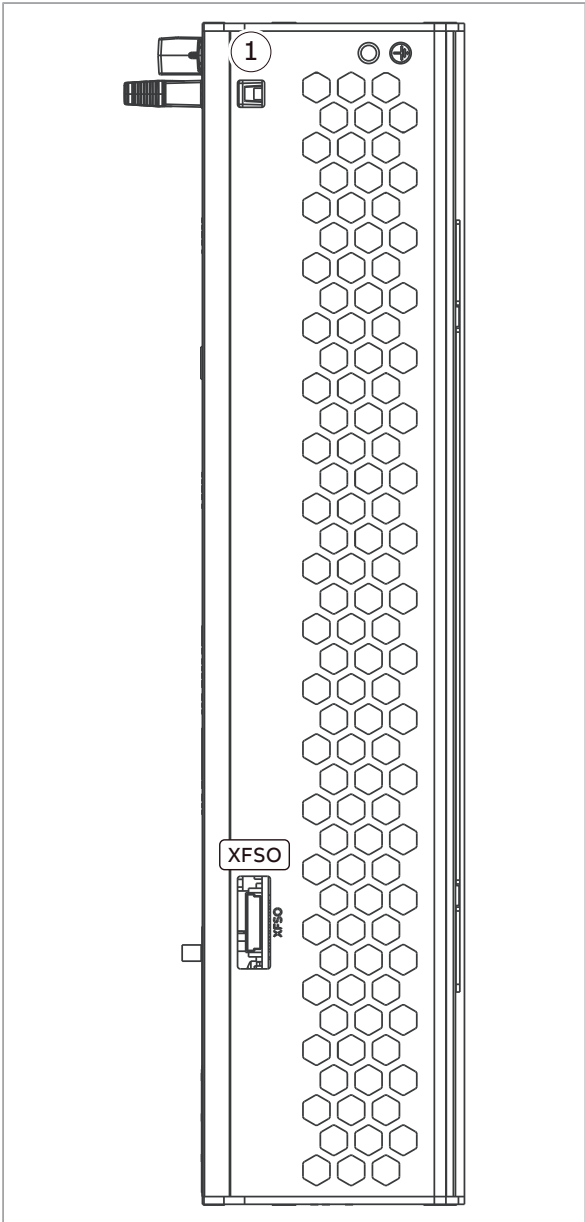













Item	Description
XF50	Optional connection for FSO safety functions module (supported only in inverter units)
1	Humidity and temperature measurements



The image shows a technical drawing of a control unit's front panel. The panel is rectangular and features a large central area with a hexagonal mesh pattern. At the top left, there is a circular port labeled '1'. To its right are two small circular indicators, one with a plus sign. Below the mesh, there is a rectangular port labeled 'XF50'. On the left side of the panel, there are two additional ports: a larger one at the top and a smaller one at the bottom. The drawing is a line-art representation of the physical unit.



Default control connection diagram of the inverter control unit

This diagram shows the default control connections of the inverter control unit. The ACS880 primary control program is in use.

Terminal			Description
XD2D			Drive-to-drive link
	1	B	Not in use by default
	2	A	
	3	BGND	
	4	SHIELD	
	XD2D.TERM		Drive-to-drive link termination switch
X485			RS485 connection
	5	B	Not in use by default
	6	A	
	7	BGND	
	8	SHIELD	
	X485 BIAS		X485 bias selection switch
	X485 TERM		X485 termination switch
XCAN			CAN bus
	9	CANH	Not supported
	10	CANL	
	11	CGND	
	12	SHIELD	Control cable shield
	XCAN TERM		CANopen termination switch

208 UCU-22, UCU-23 and UCU-24 control units

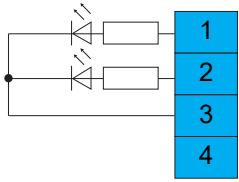
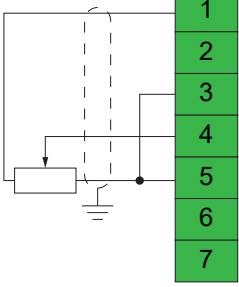
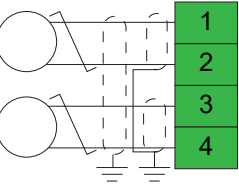
Terminal		Description		
XRO1...XRO4		Relay output 1...relay output 4		
	11	NC1	Norm. closed	XRO1: Ready (Energized = Ready) 250 V AC / 30 V DC, 2 A
	12	COM1	Common	
	13	NO1	Norm. open	
	21	NC2	Norm. closed	XRO2: Running (Energized = Running) 250 V AC / 30 V DC, 2 A
	22	COM2	Common	
	23	NO2	Norm. open	
	31	NC3	Norm. closed	XRO3: Fault (-1) (Energized = No fault) 250 V AC / 30 V DC, 2 A
	32	COM3	Common	
	33	NO3	Norm. open	
	41	NC4	Norm. closed	XRO4: Not supported 250 V AC / 30 V DC, 2 A
	42	COM4	Common	
	43	NO4	Norm. open	
	XDI		Digital inputs	
	1	DI1	Stop (0) / Start (1)	
	2	DI2	Forward (0) / Reverse (1)	
	3	DI3	Reset	
4	DI4	Acceleration & deceleration select ¹⁾		
5	DI5	Constant speed 1 select (1 = on) ²⁾		
6	DI6	Not in use by default.		
7	DIIL	Run enable. DIIL is connected to XD24:5 at the factory. ³⁾		
XD24		Auxiliary voltage output		
5	+24VD	+24 V DC 200 mA ⁴⁾		
6	DICOM	Digital input ground		
7	+24VD	+24 V DC 200 mA ⁴⁾		
8	DIOGND	Digital input/output ground		
	DICOM=DIOGND	Ground selection switch. Determines whether DICOM is separated from DIOGND (ie, common reference for digital inputs floats). ON: DICOM connected to DIOGND. OFF: DICOM and DIOGND separate.		
XSTO		Safe torque off input connection		
	1	OUT	XSTO: STO1 and STO2 are connected to OUT at the factory. To enable start and operation, STO1 and STO2 must be connected to OUT. Refer to chapter The Safe torque off function (page 389) .	
	2	SGND		
	3	STO1		
	4	STO2		
XSTO OUT		Safe torque off output connection (to inverter modules)		
	5	OUT1	XSTO OUT: Safe torque off output to inverter modules	
	6	SGND		
	7	OUT2		
	8	SGND		

Terminal			Description
XDIO			Digital input/outputs
	1	DIO1	Output: Ready
	2	DIO2	Output: Running
	3	DIOGND	Digital input/output ground
	4	DIOGND	Digital input/output ground
XAI			Analog inputs, reference voltage output
	1	+VREF	10 V DC, R_L 1...10 kohm
	2	-VREF	-10 V DC, R_L 1...10 kohm
	3	AGND	Ground
	4	AI1+	Speed reference. 0(2)...10 V, $R_{in} > 200$ kohm ⁵⁾
	5	AI1-	
	6	AI2+	Not in use by default. 0(4)...20 mA, $R_{in} = 100$ ohm ⁶⁾
	7	AI2-	
XAO			Analog outputs
	1	AO1	Motor speed rpm 0 ... 20 mA, $R_L < 500$ ohm
	2	AGND	
	3	AO2	Motor current 0 ... 20 mA, $R_L < 500$ ohm
	4	AGND	
XPOW			External power input
	1	+24VI	19...32 V DC, 1.5...2.9 A (depends on the load and supply voltage)
	2	GND	
	3	+24VI	External power input Two supplies can be connected to the control unit for redundancy.
	4	GND	
XFSO			Safety functions module connection. Support depends on the control program. Refer to the firmware manual.
XETH1			Ethernet ports for fieldbus. Support depends on the control program. Refer to the firmware manual.
XETH2			
XETH3			Ethernet ports for tool communication. Support depends on the control program. Refer to the firmware manual.
XETH4			
XPAN			Control panel connection
	XPAN TERM		Control panel connection termination switch. Used for panel bus configuration.
MEM			Memory unit connection

- 1) 0 = Acceleration/deceleration ramps defined by parameters 23.12/23.13 in use.
1 = Acceleration/deceleration ramps defined by parameters 23.14/23.15 in use.
- 2) Constant speed 1 is defined by parameter 22.26.
- 3) The DIIL input is configured to stop the unit when the input signal is removed. This input does not have a SIL or PL classification.
- 4) Total load capacity of these outputs is 4.8 W (200 mA at 24 V) minus the power taken by DIO1 and DIO2.
- 5) Current [0(4)...20 mA, $R_{in} = 100$ ohm] or voltage [0(2)...10 V, $R_{in} > 200$ kohm]. Change of setting requires reboot of control unit.
- 6) Current [0(4)...20 mA, $R_{in} = 100$ ohm] or voltage [0(2)...10 V, $R_{in} > 200$ kohm]. Change of setting requires reboot of control unit.

Additional information on the connections

■ Connecting motor temperature sensors to the drive

Refer to the electrical planning instructions.

■ Power supply for the control unit (XPOW)

Connect an additional external power supply to the free +24 V and GND terminals of the XPOW terminal block if:

- the control unit must be kept operational during input power breaks, for example, because of continuous fieldbus communication
- immediate restart is necessary after a power break (that is, no control unit power-up delay is permitted).

■ Digital interlock (DIIL)

Digital interlock input (DIIL) terminal is originally intended for interlock signals that stop the drive/unit when necessary. ABB connects this terminal to +24V DC as default at the factory.

In the ACS880 primary control program, DIIL terminal is the source for the run enable signal by default. The inverter unit or drive cannot start, or it stops when there is no DIIL signal. In other control programs (and units), the default use of the DIIL terminal varies. Refer to the firmware manual for more information.

Note: This input is **not** SIL or PL classified.

■ Control panel connection (XPAN)

The XPAN connector is the interface for an assistant control panel or FDPI-02 diagnostics and panel interface unit. With FDPI-02, it is possible to connect one control panel to two or more control units in a chain topology, also known as a panel bus. For more information, refer to [FDPI-02 diagnostics and panel interface user's manual \(3AUA0000113618 \[English\]\)](#).

The XPAN TERM switch sets the termination for the panel bus. Must be set to ON if there is no panel bus, or if the control unit is the last one in a panel bus. On intermediate units in a panel bus, set termination to OFF (1).

■ The XD2D connector

The XD2D connector has an RS-485 connection that can be used for

- basic master/follower communication between one master drive/unit and multiple followers
- fieldbus control through the embedded fieldbus (Modbus RTU)
- drive-to-drive (D2D) communication implemented by application programming.

Refer to the firmware manual for the availability of these features and related parameter settings.

Terminate the bus on the units at the ends of the drive-to-drive link. Disable bus termination on the intermediate units.

Use a shielded twisted-pair cable for data, and another pair or a wire for signal ground (nominal impedance 100...165 ohm, for example, Belden 9842). For the best immunity,

use a high-quality cable. Keep the cable as short as possible. Avoid unnecessary loops and parallel runs near power cables such as motor cables.

The following diagram shows the wiring between control units.

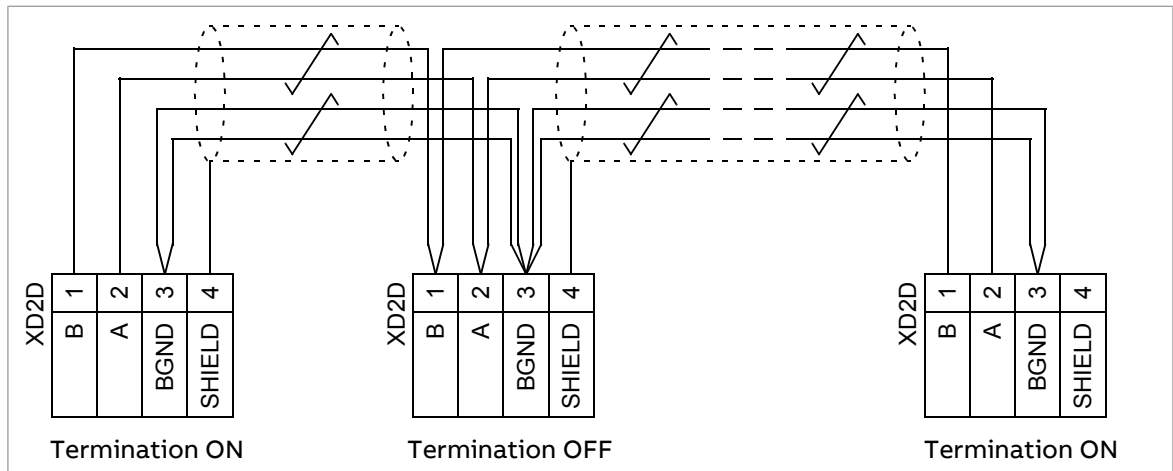

■ Safe torque off (XSTO, XSTO OUT)

Refer to chapter [The Safe torque off function](#).

The XSTO input only acts as a true Safe torque off input on the inverter control unit. De-energizing the STO input terminals of other control units (supply, DC/DC converter, or brake unit) stops the unit but does not constitute a SIL/PL classified safety function.

■ Safety functions module connection (XFSD)

In drives or inverter units with a compatible control program, an optional FSO safety functions module can be connected to the XFSD connector. The control program in supply, brake, and DC/DC converter units does not support the FSO module.

Before you connect an FSO module to the XFSD connector, make sure that the control board revision is compatible with the FSO module. For more information, refer to the applicable FSO module user's manual.

Note: Inverter modules that have a sticker with the text “No FSO support” are not compatible with the FSO safety functions module.

■ MicroSDHC memory card slot

The control unit has an on-board data logger that collects real-time data from the power modules to help fault tracing and analysis. The data is stored onto the microSDHC memory card inserted into the UMU-01 memory unit and can be analyzed by ABB service personnel.

Connector data

The wire size accepted by all screw terminals (for both stranded and solid wire) is 0.5 ... 2.5 mm² (22...12 AWG). Connector pitch is 5 mm.

Maximum tightening torque of the screw terminals is 0.45 N·m (4 lbf·in).

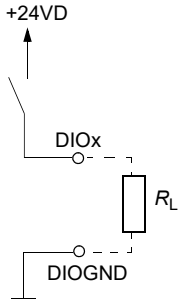
Power supply (XPOW)	19...32 V DC, 1.5 ... 2.9 A (depends on the load and supply voltage) External power input. Two supplies can be connected to the control unit for redundancy.
Relay outputs XRO1...XRO4	250 V AC / 30 V DC, 2 A Protected by varistors
+24 V output (XD24:5 and XD24:7)	Total load capacity of these outputs is 4.8 W (200 mA / 24 V) minus the power taken by DIO1 and DIO2.
Digital inputs DI1...DI6 (XDI:1...XDI:6)	24 V logic levels: "0" < 5 V, "1" > 15 V R_{in} : 2.0 kohm Input type: NPN/PNP (DI1...DI5), PNP (DI6) Hardware filtering: 0.04 ms, digital filtering up to 8 ms I_{max} : 15 mA (DI1...DI5), 5 mA (DI6)
Start interlock input DIIL (XDI:7)	24 V logic levels: "0" < 5 V, "1" > 15 V R_{in} : 2.0 kohm Input type: NPN/PNP Hardware filtering: 0.04 ms, digital filtering up to 8 ms
Digital inputs/outputs DIO1 and DIO2 (XDIO:1 and XDIO:2) Input/output mode selection by parameters. DIO1 can be configured as a frequency input (0...100 kHz with hardware filtering of 4 microseconds) for 24 V level square wave signal (sinusoidal or other wave form cannot be used). In some control programs, DIO2 can be configured as a 24 V level square wave frequency output. Refer to the firmware manual, parameter group 11.	<p><u>As inputs:</u> 24 V logic levels: "0" < 5 V, "1" > 15 V. R_{in}: 2.0 kohm. Filtering: 1 ms.</p> <p><u>As outputs:</u> Total output current from +24VD is limited to 200 mA</p> 
Reference voltage for analog inputs +VREF and -VREF (XAI:1 and XAI:2)	10 V ±1% and -10 V ±1%, R_{load} 1...10 kohm Maximum output current: 10 mA
Analog inputs AI1 and AI2 (XAI:4 ... XAI:7). Current/voltage input mode selection by parameters 12.15 AI1 unit selection and 12.25 AI2 unit selection	Current input: -20...20 mA, R_{in} = 100 ohm Voltage input: -10...10 V, R_{in} > 200 kohm Differential inputs, common mode range ±30 V Sampling interval per channel: 0.25 ms Hardware filtering: 0.25 ms Resolution: 11 bit + sign bit Inaccuracy: 1% of full scale range
Analog outputs AO1 and AO2 (XAO)	0...20 mA, R_{load} < 500 ohm Frequency range: 0...500 Hz Resolution: 11 bit + sign bit Inaccuracy: 2% of full scale range

XD2D connector	Physical layer: RS-485 Transmission rate: 8 Mbit/s Cable type: Shielded twisted-pair cable with a twisted pair for data and a wire or another pair for signal ground (nominal impedance 100 ... 165 ohm, for example Belden 9842) Maximum length of link: 50 m (164 ft) Termination by switch
RS-485 connection (X485)	Physical layer: RS-485 Cable type: Shielded twisted-pair cable with a twisted pair for data and a wire or another pair for signal ground (nominal impedance 100 ... 165 ohm, for example Belden 9842) Maximum length of link: 50 m (164 ft) Termination and bias by switch (X485 TERM and X485 BIAS)
CAN connection (XCAN)	Termination by switch (XCAN TERM) This connection is not supported by the ACS880 control programs.
Safe torque off connection (XSTO)	Input voltage range: -3...30 V DC Logic levels: "0" < 5 V, "1" > 17 V. Note: Both circuits must be closed to enable start and operation (STO1 and STO2 must be connected to OUT). This applies to all control units (including drive, inverter, supply, brake, DC/DC converter etc. control units), but SIL/PL classified Safe torque off functionality is only achieved through the XSTO connector of the drive/inverter control unit. Current consumption (continuous) per STO channel: 15 mA. The number of parallel inverter modules does not have an effect on the current consumption. EMC (immunity) according to IEC 61326-3-1 and IEC 61800-5-2 See also chapter The Safe torque off function (page 389) .
Safe torque off output (XSTO OUT)	To STO connector of inverter module.
Control panel connection (XPAN)	Connector: RJ-45 Cable length < 50 m (164 ft) Termination by switch (XPAN TERM)
Control Ethernet connection with internal switch (XETH1 and XETH2)	Connector: RJ-45 Cable type: minimum requirement CAT5e
Tool Ethernet connection with internal switch (XETH3 and XETH4)	Connector: RJ-45 Cable type: minimum requirement CAT5e
microSDHC memory card slot (microSDHC CARD)	Memory card type: microSDHC (minimum of class 4 speed grade) Supported memory size: 4 GB...32 GB
Battery	Real-time clock battery type: BR2032
The terminals of the control unit fulfill the Protective Extra Low Voltage (PELV) requirements. The PELV requirements of a relay output are not fulfilled if a voltage higher than 48 V is connected to the relay output.	

■ Ground isolation diagram

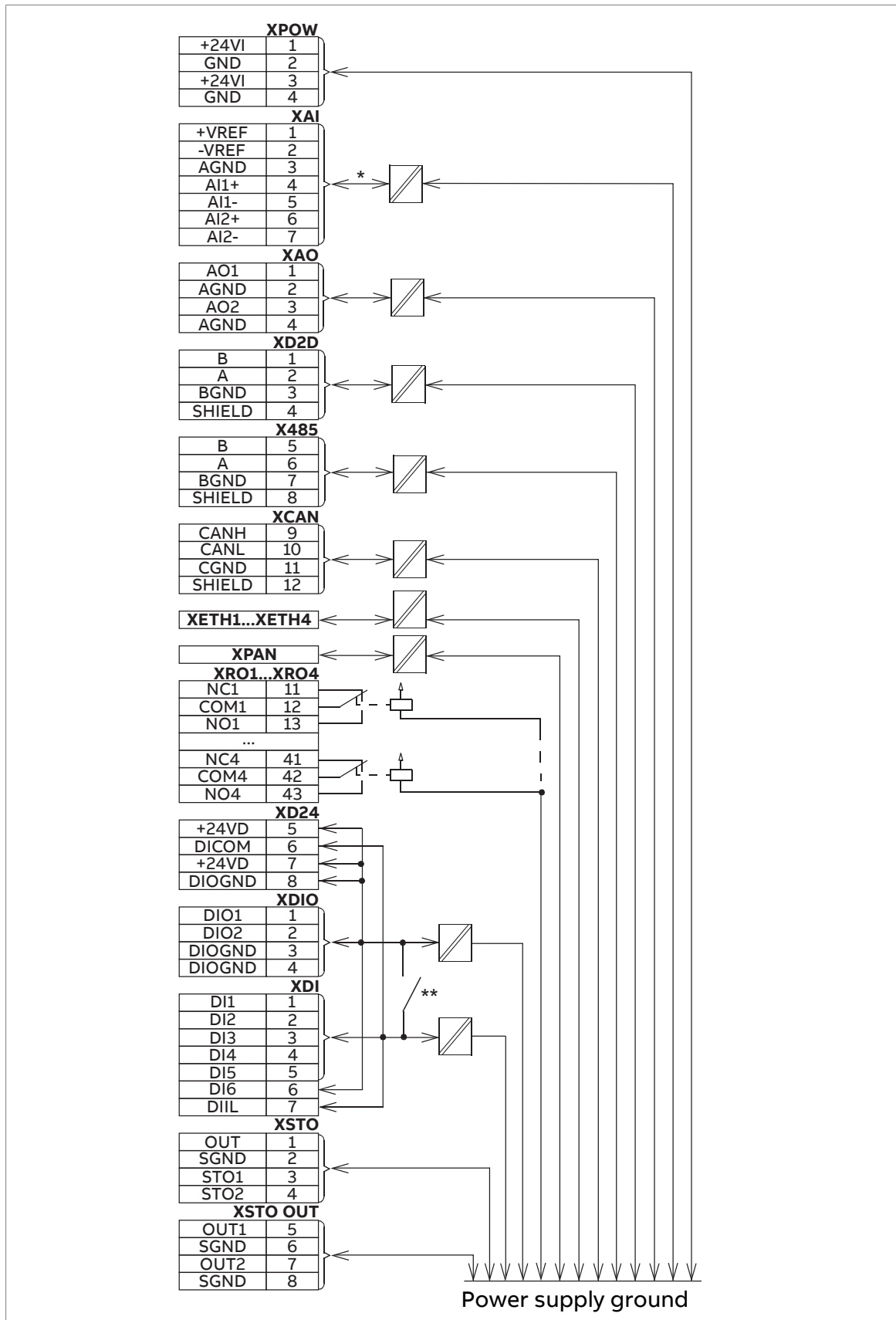

*The maximum common mode voltage between each AI input and AGND is ± 30 V.

****Ground selector (DICOM=DIOGND) settings**

DICOM=DIOGND: ON

All digital inputs share a common ground (DICOM connected to DIOGND). This is the default setting.

DICOM=DIOGND: OFF

Ground of digital inputs DI1...DI5 and DIIL (DICOM) is isolated from DIO signal ground (DIOGND). Isolation voltage 50 V.

■ Ground isolation diagram

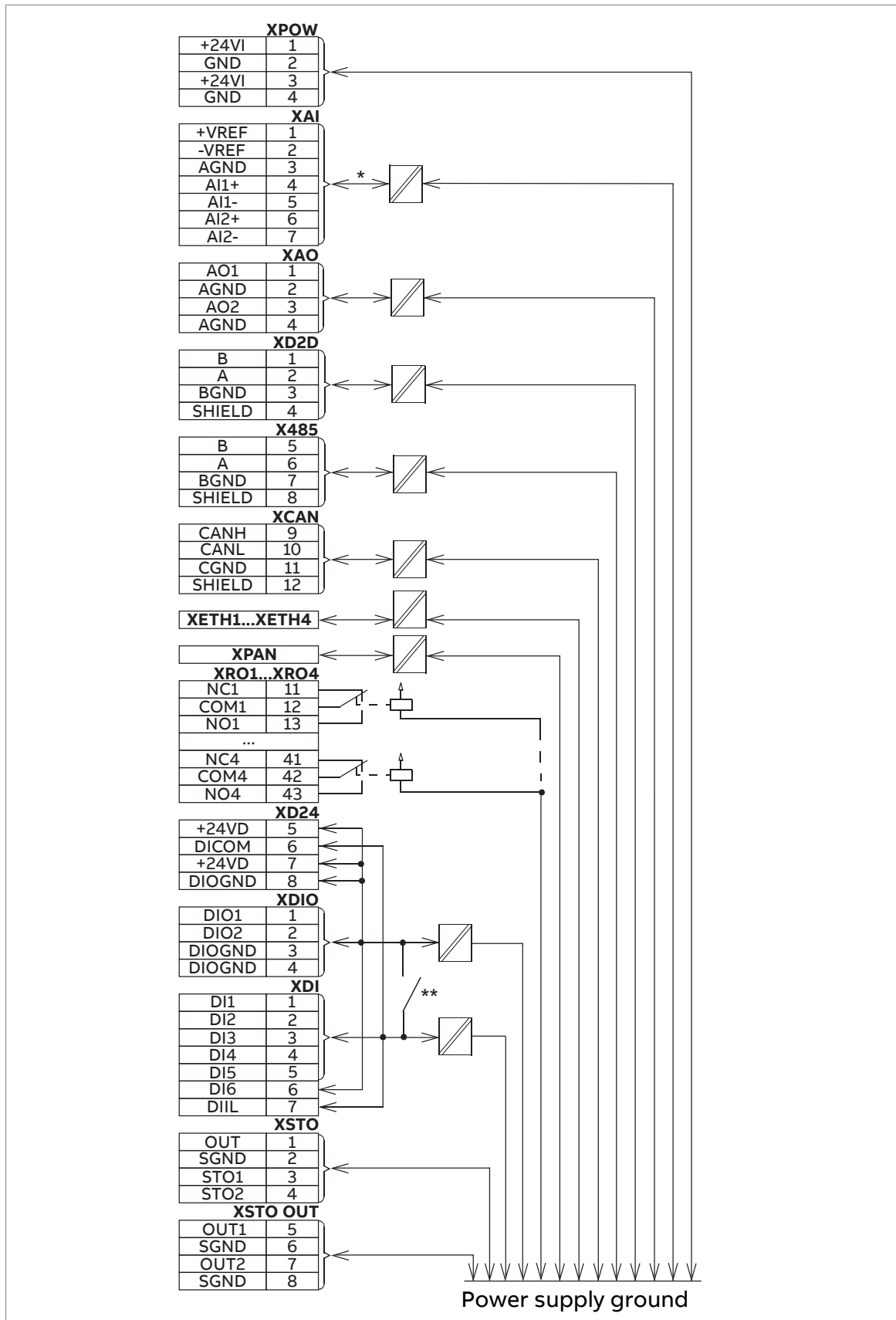

*The maximum common mode voltage between each AI input and AGND is ± 30 V.

****Ground selector (DICOM=DIOGND) settings**

DICOM=DIOGND: ON

All digital inputs share a common ground (DICOM connected to DIOGND). This is the default setting.

DICOM=DIOGND: OFF

Ground of digital inputs DI1...DI5 and DIIL (DICOM) is isolated from DIO signal ground (DIOGND). Isolation voltage 50 V.

Other information

Refer to [UCU-22, UCU-23 and UCU-24 control units hardware manual \(3AXD50000817726 \[English\]\)](#).



BCU and ZCU control units

Contents of this chapter

This chapter

- gives information on the connections of the control unit, and
- has the specifications of the inputs and outputs of the control unit.

General

The control unit controls the inverter unit. The control unit is connected to the inverter module(s) through fiber-optic cables.

ZCU-12 layout

This figure shows the layout of the ZCU-12 control unit.

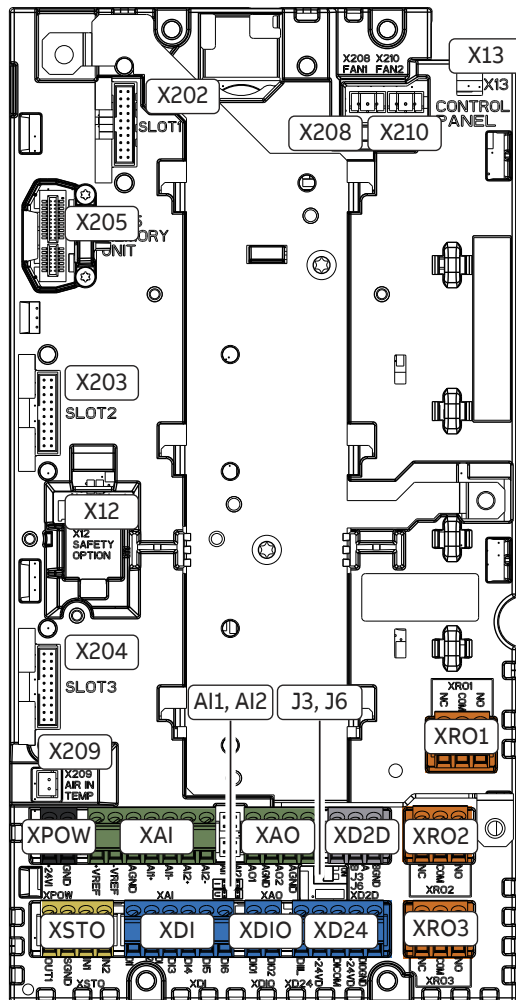

	Description
XAI	Analog inputs
XAO	Analog outputs
XDI	Digital inputs
XDIO	Digital input/outputs
XD24	Digital input interlock (DIIL) and +24 V output
XD2D	Drive-to-drive link or Modbus/RTU
XPOW	External power input
XRO1	Relay output RO1
XRO2	Relay output RO2
XRO3	Relay output RO3
XSTO	Safe torque off connection
X12	Connection for FSO safety functions module
X13	Control panel connection
X202	Option slot 1
X203	Option slot 2
X204	Option slot 3
X205	Memory unit connection
X208	Cooling fan 1 connection
X209	Connection for ambient temperature sensor (at air inlet). Connected at the factory.
X210	Cooling fan 2 connection
AI1, AI2	Current/Voltage selection jumpers (J1, J2) for analog inputs
J3	Drive-to-drive link termination switch (J3)
J6	Common digital input ground selection switch (J6)

ZCU-14 layout

This figure shows the layout of the ZCU-14 control unit.

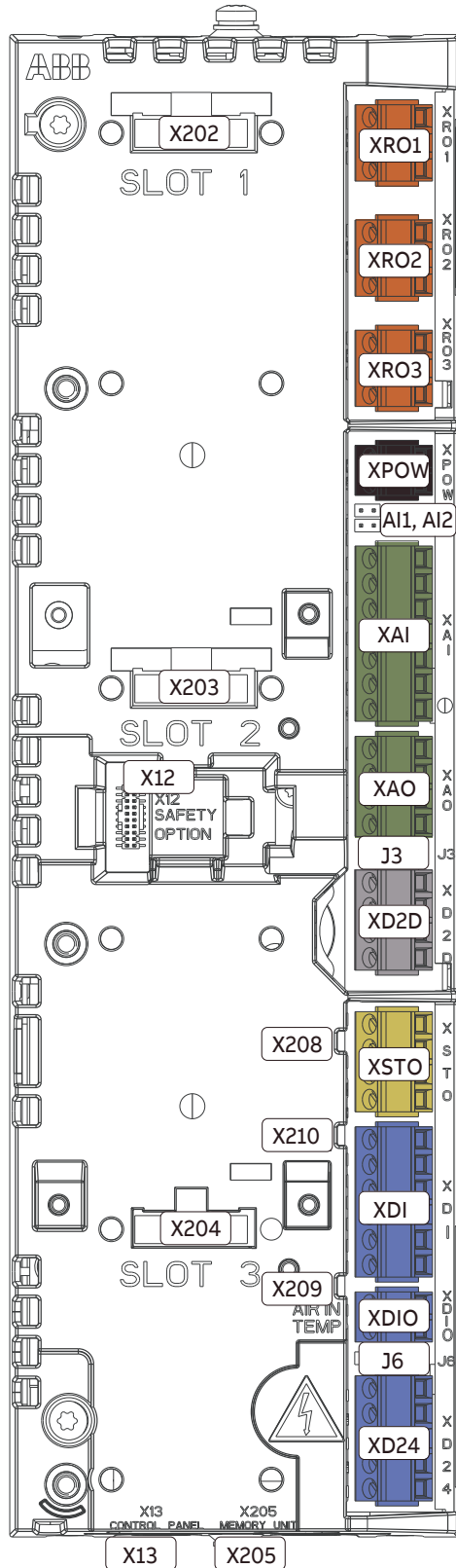

	Description
XPOW	External power input
XAI	Analog inputs
XAO	Analog outputs
XD2D	Drive-to-drive link or Modbus/RTU
XRO1	Relay output RO1
XRO2	Relay output RO2
XRO3	Relay output RO3
XD24	Digital input interlock (DIIL) and +24 V output
XDIO	Digital input/outputs
XDI	Digital inputs
XSTO	Safe torque off connection (inverter unit only). Note: This connection only acts as a true Safe torque off input when the ZCU is controlling an inverter unit. When the ZCU is controlling a supply unit, de-energizing the inputs will stop the unit but will not constitute a true safety function.
X12	Connection for FSO safety functions module (inverter unit only).
X13	Control panel connection
X202	Option slot 1
X203	Option slot 2
X204	Option slot 3
X205	Memory unit connection
X208	Cooling fan 1 connection
X209	Connection for ambient temperature sensor (at air inlet). Connected at the factory.
X210	Cooling fan 2 connection
AI1, AI2	Voltage/Current selection jumpers (AI1, AI2) for analog inputs
J3	Drive-to-drive link termination switch (J3)
J6	Common digital input ground selection jumper (J6).

Default control connection diagram of the inverter control unit (ZCU)

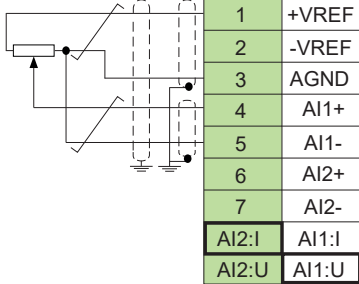
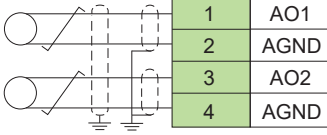
Connection	Term	Description																		
XPOW External power input																				
	+24VI	24 V DC, 2 A min. (without optional modules)																		
	GND																			
XAI Reference voltage and analog inputs																				
	+VREF	10 V DC, R_L 1...10 kohm																		
	-VREF	-10 V DC, R_L 1...10 kohm																		
	AGND	Ground																		
	AI1+	Speed reference																		
	AI1-	0(2)...10 V, $R_{in} > 200$ kohm ¹⁾																		
	AI2+	By default not in use.																		
	AI2-	0(4)...20 mA, $R_{in} = 100$ ohm ¹⁾																		
	AI1 (ZCU-12) J1 (ZCU-14)	Current (I) / voltage (U) selection jumper for AI1																		
	AI2 (ZCU-12) J2 (ZCU-14)	Current (I) / voltage (U) selection jumper for AI2																		
	XAO Analog outputs																			
	AO1	Motor speed rpm																		
	AGND	0...20 mA, $R_L < 500$ ohm																		
	AO2	Motor current																		
	AGND	0...20 mA, $R_L < 500$ ohm																		
XD2D Drive-to-drive link																				
<table border="0"> <tr> <td colspan="2">ZCU-12:</td> </tr> <tr> <td>1</td> <td>B</td> </tr> <tr> <td>2</td> <td>A</td> </tr> <tr> <td>3</td> <td>BGND</td> </tr> <tr> <td colspan="2">ZCU-14:</td> </tr> <tr> <td>1</td> <td>B</td> </tr> <tr> <td>2</td> <td>A</td> </tr> <tr> <td>3</td> <td>BGND</td> </tr> <tr> <td>4</td> <td>Shield</td> </tr> </table>	ZCU-12:		1	B	2	A	3	BGND	ZCU-14:		1	B	2	A	3	BGND	4	Shield	B	Master/follower, drive-to-drive or embedded fieldbus connection
	ZCU-12:																			
	1	B																		
	2	A																		
	3	BGND																		
	ZCU-14:																			
	1	B																		
	2	A																		
3	BGND																			
4	Shield																			
A																				
BGND																				
Shield (ZCU-14 only)																				
J3	Drive-to-drive link termination																			

Connection	Term	Description				
XRO1, XRO2, XRO3 Relay outputs						
	NC	Ready run				
	COM	250 V AC / 30 V DC				
	NO	2 A				
	NC	Running				
	COM	250 V AC / 30 V DC				
	NO	2 A				
	NC	Fault (-1)				
	COM	250 V AC / 30 V DC				
	NO	2 A				
XD24 Auxiliary voltage output, digital interlock						
	DIIL	Run enable				
	+24VD	+24 V DC 200 mA ²⁾				
	DICOM	Digital input ground				
	+24VD	+24 V DC 200 mA ²⁾				
	DIOGND	Digital input/output ground				
XDIO Digital input/outputs						
<table border="1"> <tr><td>1</td><td>DIO1</td></tr> <tr><td>2</td><td>DIO2</td></tr> </table>	1	DIO1	2	DIO2	DIO1	Output: Ready run
	1	DIO1				
	2	DIO2				
DIO2	Output: Running					
J6	Ground selection ³⁾					
XDI Digital inputs						
	DI1	Stop (0) / Start (1)				
	DI2	Forward (0) / Reverse (1)				
	DI3	Reset				
	DI4	Acc/Dec time select ⁴⁾				
	DI5	Constant speed 1 (1 = On) ⁵⁾				
	DI6	By default, not in use.				
XSTO Safe torque off connection						
	OUT1 (ZCU-12) OUT (ZCU-14)	IN1 and IN2 are connected to OUT1 (ZCU-12) or OUT (ZCU-14) at the factory. To enable start and operation, IN1 and IN2 must be connected to OUT1 or OUT. Refer to chapter The Safe torque off function (page 389) .				
	SGND					
	IN1					
	IN2					
X12						
Safety options connection						

224 BCU and ZCU control units

Connection	Term	Description
X13		Control panel connection
X205		Memory unit connection

- 1) Current [0(4)...20 mA, $R_{in} = 100 \text{ ohm}$] or voltage [0(2)...10 V, $R_{in} > 200 \text{ kohm}$] input selected by jumper. Change of setting requires reboot of control unit.
 - 2) Total load capacity of these outputs is 4.8 W (200 mA at 24 V) minus the power taken by DIO1 and DIO2.
 - 3) Determines whether DICOM is separated from DIOGND (ie. common reference for digital inputs floats; in practice, selects whether the digital inputs are used in current sinking or sourcing mode). Refer to [ZCU ground isolation diagram \(page 236\)](#). DICOM=DIOGND ON: DICOM connected to DIOGND. OFF: DICOM and DIOGND separate.
 - 4) 0 = Acceleration/deceleration ramps defined by parameters 23.12/23.13 in use. 1 = Acceleration/deceleration ramps defined by parameters 23.14/23.15 in use.
 - 5) Constant speed 1 is defined by parameter 22.26.
-

Layout (BCU)



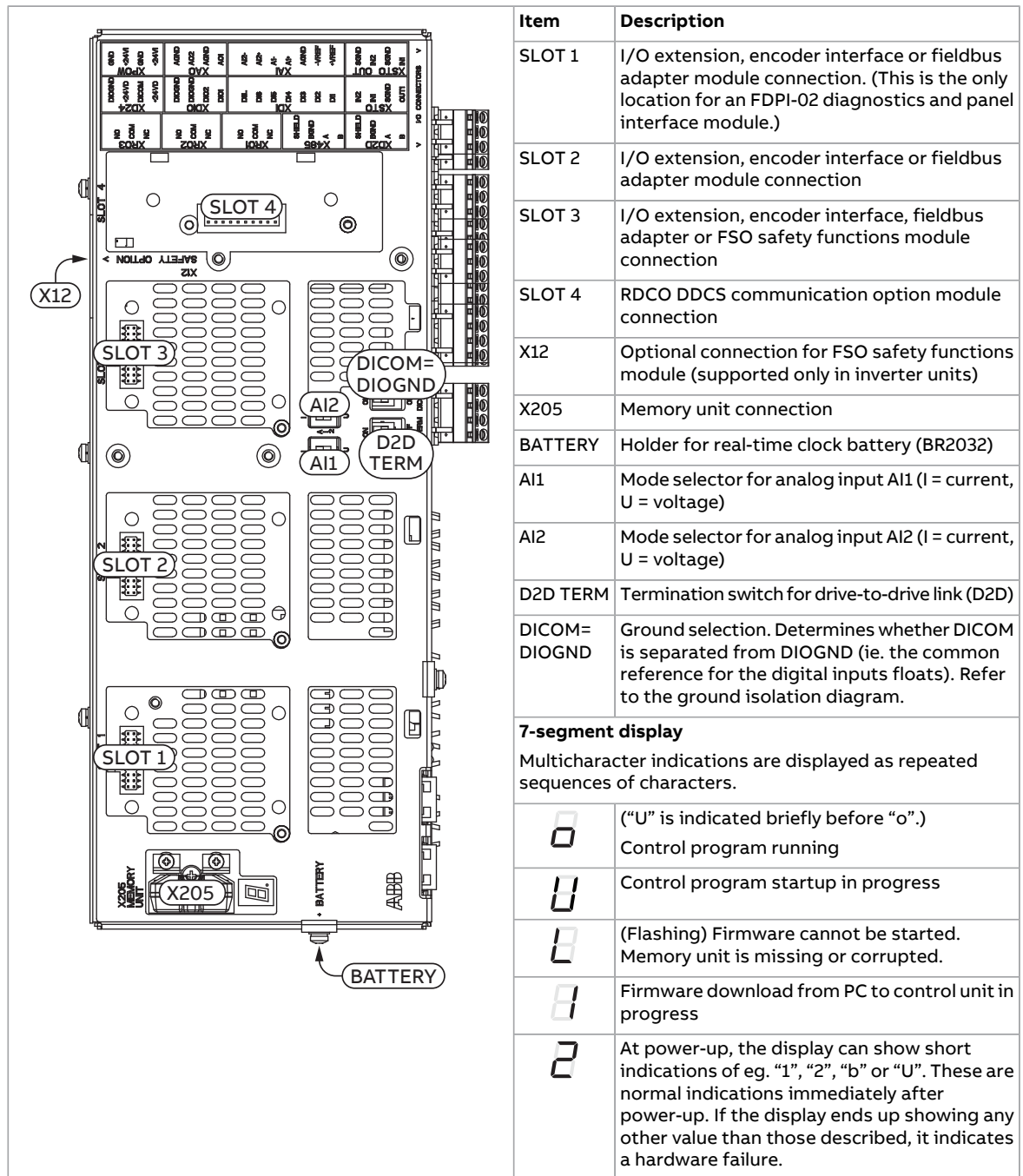

The figures below show an example layout of the BCU control unit.







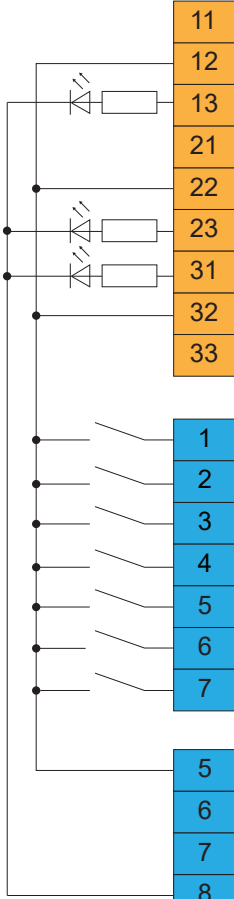

Item	Description
XAI	Analog input
XAO	Analog output
XDI	Digital input
XDIO	Digital input/output
XD2D	Drive-to-drive link or Modbus/RTU
XD24	+24 V output (for digital input)
XETH	Ethernet port (not in use)
XPOW	External power input
XRO1	Relay output RO1
XRO2	Relay output RO2
XRO3	Relay output RO3
XSTO	Safe torque off connection (input signals)
XSTO OUT	Safe torque off connection (to inverter modules)
X13	Control panel connection (PC connection through control panel)
X485	Not in use by default
V1T/V1R ... V12T/V12R	Fiber optic connections (VxT = transmitter, VxR = receiver) <u>BCU-02</u> : V1T/V1R ... V2T/V2R <u>BCU-12</u> : V1T/V1R ... V7T/V7R <u>BCU-22</u> : V1T/V1R ... V12T/V12R
SD CARD	Data logger memory card
BATT OK LED	When the BATT OK LED is on, the real-time clock battery voltage is higher than 2.8 V. If the LED is off when the control unit is energized, the battery must be replaced.
PWR OK LED	When the PWR OK LED is on, the voltage supply is sufficient.
FAULT LED	If the FAULT LED is on, the control program has generated a fault. Refer to the firmware manual.
WRITE LED	When the WRITE LED is on, writing to the memory card is in progress. Do not remove the memory card.

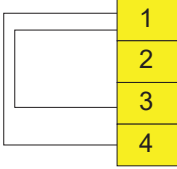
Default control connection diagram of the inverter control unit (BCU)

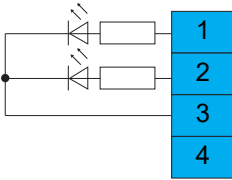
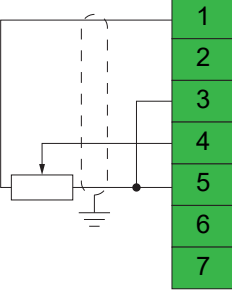
This diagram shows the default control connections of the inverter control unit. The ACS880 primary control program is in use.

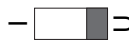
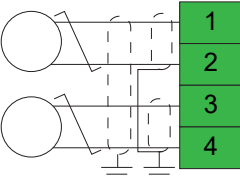
Terminal			Description		
XD2D			Drive-to-drive link		
		1 B 2 A 3 BGND 4 Shield	Not in use by default		
		D2D.TERM		Drive-to-drive link termination switch	
X485				RS485 connection	
		5 B 6 A 7 BGND 8 Shield		Not in use by default	
XRO1...XRO3			Relay outputs		
	11	NC	Norm. closed		XRO1: Ready (Energized = Ready) 250 V AC / 30 V DC, 2 A
	12	COM	Common		
	13	NO	Norm. open		
	21	NC	Norm. closed	XRO2: Running (Energized = Running) 250 V AC / 30 V DC, 2 A	
	22	COM	Common		
	23	NO	Norm. open		
	31	NC	Norm. closed	XRO3: Fault (-1) (Energized = No fault) 250 V AC / 30 V DC, 2 A	
	32	COM	Common		
	33	NO	Norm. open		
	XDI			Digital inputs	
			1 DI1 2 DI2 3 DI3 4 DI4 5 DI5 6 DI6 7 DIIL	Stop (0) / Start (1)	
				Forward (0) / Reverse (1)	
			Reset		
			Acceleration & deceleration select ¹⁾		
			Constant speed 1 select (1 = on) ²⁾		
			Not in use by default.		
			Run enable. DIIL is connected to XD24:5 at the factory. ³⁾		
XD24			Auxiliary voltage output		
		5 +24VD 6 DICOM 7 +24VD 8 DIOGND	+24 V DC 200 mA ⁴⁾		
			Digital input ground		
			+24 V DC 200 mA ⁴⁾		
			Digital input/output ground		

Terminal		Description	
	DICOM=DIOGND		Ground selection switch. Determines whether DICOM is separated from DIOGND (ie, common reference for digital inputs floats). ON: DICOM connected to DIOGND. OFF: DICOM and DIOGND separate.
XSTO		Safe torque off input connection	
	1 2 3 4	OUT SGND IN1 IN2	XSTO: IN1 and IN2 are connected to OUT at the factory. To enable start and operation, IN1 and IN2 must be connected to OUT. Refer to chapter The Safe torque off function (page 389) .
XSTO OUT		Safe torque off output connection (to inverter modules)	
	5 6 7 8	IN1 SGND IN2 SGND	XSTO OUT: Safe torque off output to inverter modules
XDIO		Digital input/outputs	
	1 2 3 4	DIO1 DIO2 DIOGND DIOGND	Output: Ready Output: Running Digital input/output ground Digital input/output ground
XAI		Analog inputs, reference voltage output	
	1 2 3 4 5 6 7	+VREF -VREF AGND AI1+ AI1- AI2+ AI2-	10 V DC, R_L 1 ... 10 kohm -10 V DC, R_L 1 ... 10 kohm Ground Speed reference. 0(2)...10 V, $R_{in} > 200$ kohm ⁵⁾ Not in use by default. 0(4)...20 mA, $R_{in} = 100$ ohm ⁶⁾
	AI1		AI1 current/voltage selection switch
	AI2		AI2 current/voltage selection switch
XAO		Analog outputs	
	1 2 3 4	AO1 AGND AO2 AGND	Motor speed rpm 0 ... 20 mA, $R_L < 500$ ohm Motor current 0 ... 20 mA, $R_L < 500$ ohm
XPOW		External power input	
	1 2 3 4	+24VI GND +24VI GND	24 VDC ($\pm 10\%$), 2 A External power input Two supplies can be connected to the control unit for redundancy.

Terminal	Description
X12	Safety functions module connection. Not in use by default.
X13	Control panel connection
X205	Memory unit connection

- 1) 0 = Acceleration/deceleration ramps defined by parameters 23.12/23.13 in use.
1 = Acceleration/deceleration ramps defined by parameters 23.14/23.15 in use.
 - 2) Constant speed 1 is defined by parameter 22.26.
 - 3) The DIIL input is configured to stop the unit when the input signal is removed. This input does not have a SIL or PL classification.
 - 4) Total load capacity of these outputs is 4.8 W (200 mA at 24 V) minus the power taken by DIO1 and DIO2.
 - 5) Current [0(4)...20 mA, $R_{in} = 100 \text{ ohm}$] or voltage [0(2)...10 V, $R_{in} > 200 \text{ kohm}$] input selected by switch AI1. Change of setting requires reboot of control unit.
 - 6) Current [0(4)...20 mA, $R_{in} = 100 \text{ ohm}$] or voltage [0(2)...10 V, $R_{in} > 200 \text{ kohm}$] input selected by switch AI2. Change of setting requires reboot of control unit.
-

Additional information on the connections

■ Connecting motor temperature sensors to the drive

Refer to the electrical planning instructions.

■ Power supply for the control unit (XPOW)

Connect an additional external power supply to the free +24 V and GND terminals of the XPOW terminal block if:

- the control unit must be kept operational during input power breaks, for example, because of continuous fieldbus communication
- immediate restart is necessary after a power break (that is, no control unit power-up delay is permitted).

■ Digital interlock (DIIL)

Digital interlock input (DIIL) terminal is originally intended for interlock signals that stop the drive/unit when necessary. ABB connects this terminal to +24V DC as default at the factory.

In the ACS880 primary control program, DIIL terminal is the source for the run enable signal by default. The inverter unit or drive cannot start, or it stops when there is no DIIL signal. In other control programs (and units), the default use of the DIIL terminal varies. Refer to the firmware manual for more information.

Note: This input is **not** SIL or PL classified.

■ The XD2D connector

The XD2D connector provides an RS-485 connection that can be used for

- basic master/follower communication with one master drive and multiple followers,
- fieldbus control through the embedded fieldbus interface (EFB), or
- drive-to-drive (D2D) communication implemented by application programming.

Refer to the firmware manual for the related parameter settings.

Terminate the bus on the units at the ends of the drive-to-drive link. Disable bus termination on the intermediate units.

Use a shielded twisted-pair cable for data, and another pair or a wire for signal ground (nominal impedance 100...165 ohm, for example Belden 9842). For the best immunity, ABB recommends high quality cable. Keep the cable as short as possible. Avoid unnecessary loops and parallel runs near power cables such as motor cables.

The diagram that follows shows the wiring of the drive-to-drive link. The diagram is applicable to ZCU-12 control units.

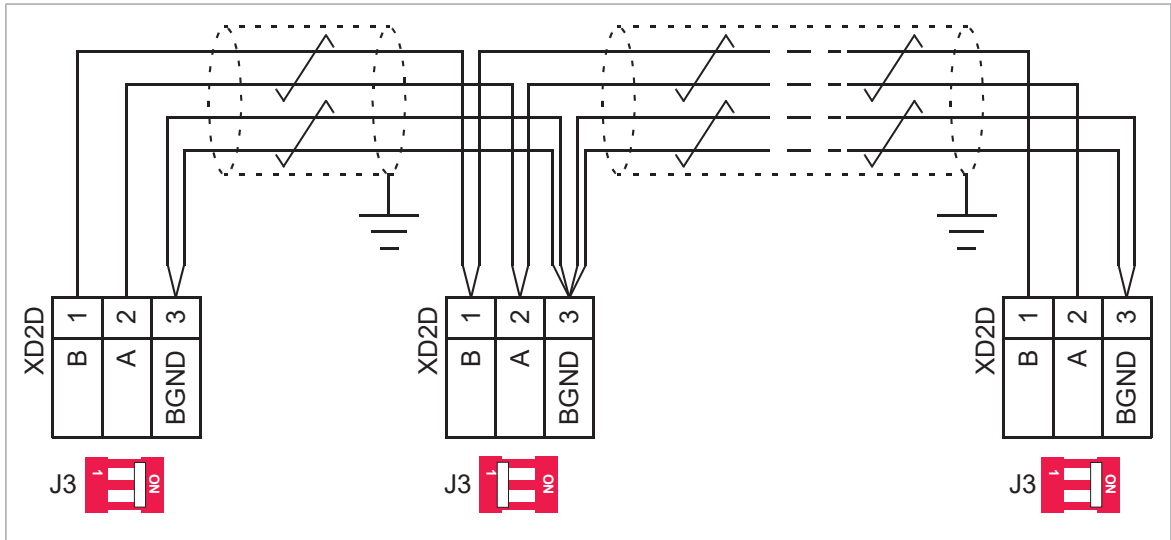

The diagram that follows shows the wiring of the drive-to-drive link. The diagram is applicable to these control units:

- BCU-02/12/22
- ZCU-14

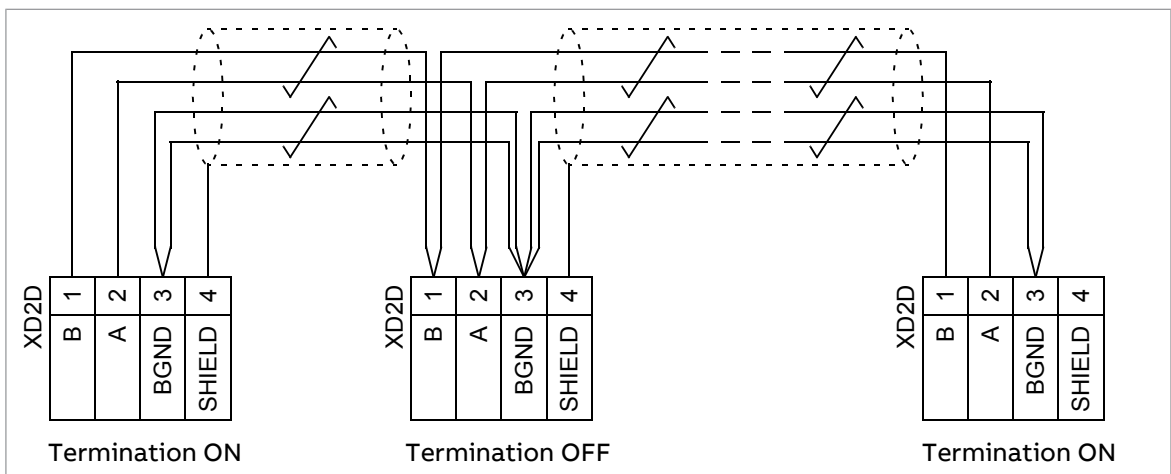

■ Safe torque off (XSTO, XSTO OUT)

Refer to chapter [The Safe torque off function](#).

The XSTO input only acts as a true Safe torque off input on the inverter control unit. De-energizing the STO input terminals of other control units (supply, DC/DC converter, or brake unit) stops the unit but does not constitute a SIL/PL classified safety function.

■ Safety functions module connection (X12)

In drives or inverter units with a compatible control program, an optional FSO safety functions module can be connected to the X12 connector. The control program in supply, brake, and DC/DC converter units does not support the FSO safety functions module.

For more information on the FSO safety functions module, refer to the applicable FSO module user's manual.

Note: Inverter modules and control units that have a sticker with the text “No FSO support” are not compatible with the FSO safety functions module.

■ **SDHC memory card slot**

The control unit has an on-board data logger that collects real-time data from the power modules to help fault tracing and analysis. The data is stored onto the SDHC memory card inserted into the SD CARD slot and can be analyzed by ABB service personnel.

Connector data

The wire size accepted by all screw terminals (for both stranded and solid wire) is 0.5 ... 2.5 mm² (22...12 AWG). Connector pitch is 5 mm.

The maximum tightening torque for screw terminals is:

- 0.45 N·m (4 lbf·in) for BCU control units
- 0.5 N·m (5 lbf·in) for ZCU control units.

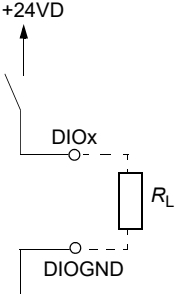
Power supply (XPOW)	24 V DC ($\pm 10\%$), 2 A (BCU) 24 V DC ($\pm 10\%$), 2 A (ZCU) External power input. Two supplies can be connected to the BCU control unit for redundancy.
Relay outputs RO1...RO3 (XRO1...XRO3)	250 V AC / 30 V DC, 2 A Protected by varistors
+24 V output (XD24:5 and XD24:7)	Total load capacity of these outputs is 4.8 W (200 mA / 24 V) minus the power taken by DIO1 and DIO2.
Digital inputs DI1...DI6 (XDI:1...XDI:6)	24 V logic levels: "0" < 5 V, "1" > 15 V R_{in} : 2.0 kohm (DI1...DI5) Input type: NPN/PNP (DI1...DI5), PNP (DI6) Hardware filtering: 0.04 ms, digital filtering up to 8 ms I_{max} : 15 mA (DI1...DI5), 5 mA (DI6)
Start interlock input DIIL (XD24:1 [ZCU], XDI:7 [BCU])	24 V logic levels: "0" < 5 V, "1" > 15 V R_{in} : 2.0 kohm Input type: NPN/PNP Hardware filtering: 0.04 ms, digital filtering up to 8 ms
Digital inputs/outputs DIO1 and DIO2 (XDIO:1 and XDIO:2) Input/output mode selection by parameters. DIO1 can be configured as a frequency input (0...16 kHz with hardware filtering of 4 microseconds) for 24 V level square wave signal (sinusoidal or other wave form cannot be used). In some control programs, DIO2 can be configured as a 24 V level square wave frequency output. Refer to the firmware manual, parameter group 11.	<u>As inputs:</u> 24 V logic levels: "0" < 5 V, "1" > 15 V. R_{in} : 2.0 kohm. Filtering: 1 ms. <u>As outputs:</u> Total output current from +24VD is limited to 200 mA 
Reference voltage for analog inputs +VREF and -VREF (XAI:1 and XAI:2)	10 V $\pm 1\%$ and -10 V $\pm 1\%$, R_{load} 1...10 kohm Maximum output current: 10 mA
Analog inputs AI1 and AI2 (XAI:4 ... XAI:7). Current/voltage input mode selection by jumpers (ZCU) or switches (BCU)	Current input: -20...20 mA, R_{in} = 100 ohm Voltage input: -10...10 V, R_{in} > 200 kohm Differential inputs, common mode range ± 30 V Sampling interval per channel: 0.25 ms Hardware filtering: 0.25 ms Resolution: 11 bit + sign bit Inaccuracy: 1% of full scale range

234 BCU and ZCU control units

Analog outputs AO1 and AO2 (XAO)	<p>0...20 mA, $R_{load} < 500 \text{ ohm}$</p> <p>Frequency range: 0...300 Hz (ZCU), 0...500 Hz (BCU)</p> <p>Resolution: 11 bit + sign bit</p> <p>Inaccuracy: 2% of full scale range</p>
XD2D connector	<p>Physical layer: RS-485</p> <p>Transmission rate: 8 Mbit/s</p> <p>Cable type: Shielded twisted-pair cable with a twisted pair for data and a wire or another pair for signal ground (nominal impedance 100 ... 165 ohm, for example Belden 9842)</p> <p>Maximum length of link: 50 m (164 ft)</p> <p>Termination by jumper (ZCU) or switch (BCU)</p>
RS-485 connection (X485 [BCU])	<p>Physical layer: RS-485</p> <p>Cable type: Shielded twisted-pair cable with a twisted pair for data and a wire or another pair for signal ground (nominal impedance 100 ... 165 ohm, for example Belden 9842)</p> <p>Maximum length of link: 50 m (164 ft)</p>
Safe torque off connection (XSTO)	<p>Input voltage range: -3...30 V DC</p> <p>Logic levels: "0" < 5 V, "1" > 17 V.</p> <p>Note: Both circuits must be closed to enable start and operation (IN1 and IN2 must be connected to OUT). This applies to all control units (including drive, inverter, supply, brake, DC/DC converter etc. control units), but SIL/PL classified Safe torque off functionality is only achieved through the XSTO connector of the drive/inverter control unit.</p> <p>Current consumption (continuous) per STO channel:</p> <ul style="list-style-type: none"> • <u>Frames R1i...R4i</u>: 56 mA • <u>Frame R5i</u>: 21 mA • <u>Frames R6i...R7i</u>: 41.5 mA • <u>Frames R6i...R7i with option +V992</u>: 25 mA • <u>Frame R8i with BCU control unit</u>: 66 mA per parallel inverter module <p>EMC (immunity) according to IEC 61326-3-1 and IEC 61800-5-2 See also chapter The Safe torque off function (page 389).</p>
Safe torque off output (XSTO OUT) (BCU control units only)	To STO connector of inverter module.
Control panel connection (X13)	<p>Connector: RJ-45</p> <p>Cable length < 100 m (328 ft)</p>
Ethernet connection (XETH [BCU])	<p>Connector: RJ-45</p> <p>This connection is not supported by the firmware</p>
SDHC memory card slot (SD CARD [BCU])	<p>Memory card type: SDHC</p> <p>Maximum memory size: 4 GB</p>
Battery	Real-time clock battery type: BR2032
<p>The terminals of the control unit fulfill the Protective Extra Low Voltage (PELV) requirements. The PELV requirements of a relay output are not fulfilled if a voltage higher than 48 V is connected to the relay output.</p>	

■ BCU ground isolation diagram

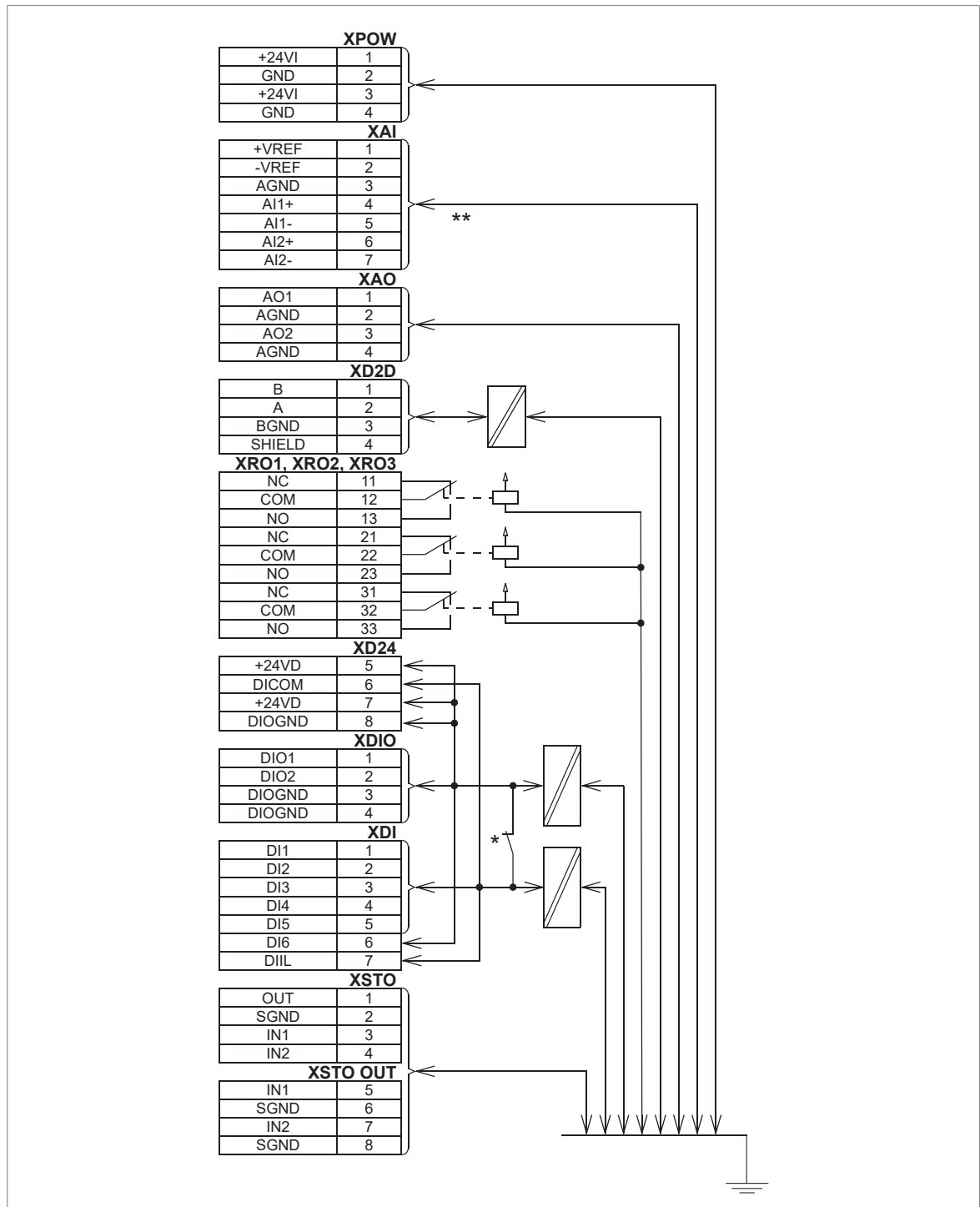

***Ground selector (DICOM=DIOGND) settings**

DICOM=DIOGND: ON
All digital inputs share a common ground (DICOM connected to DIOGND). This is the default setting.
DICOM=DIOGND: OFF
Ground of digital inputs DI1...DI5 and DIIL (DICOM) is isolated from DIO signal ground (DIOGND). Isolation voltage 50 V.

**The maximum common mode voltage between each AI input and AGND is +30 V

■ ZCU ground isolation diagram

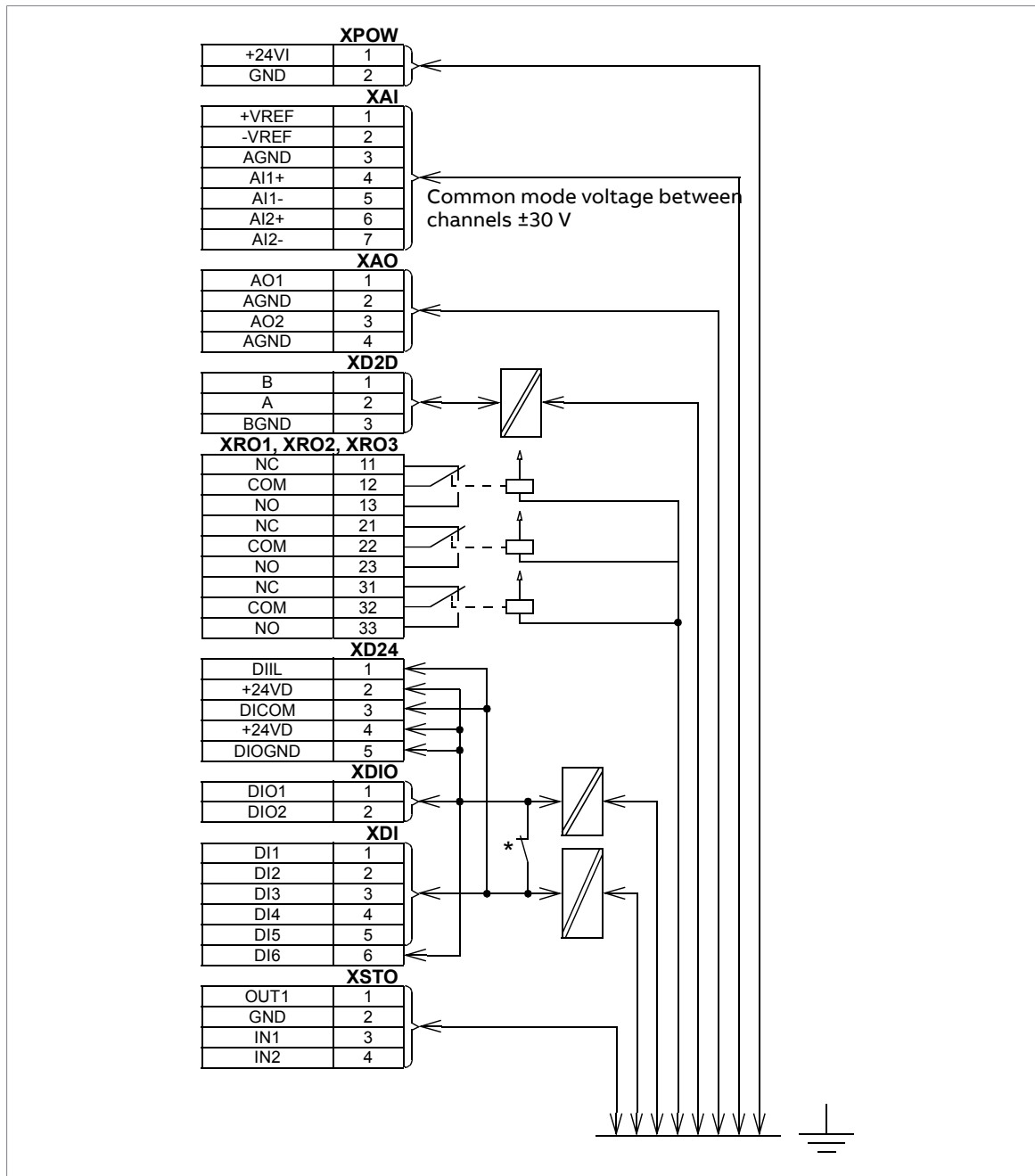

* Ground selector (J6) settings

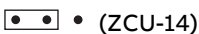
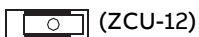

All digital inputs share a common ground (DICOM connected to DIOGND). This is the default setting.

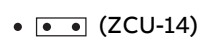
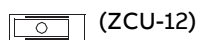

Ground of digital inputs DI1...DI5 and DIIL (DICOM) is isolated from DIO signal ground (DIOGND). Isolation voltage 50 V.

Other information

Refer to [BCU-02, BCU-12 and BCU-22 control units hardware manual \(3AUA0000113605 \[English\]\)](#).

8

Installation checklist

Contents of this chapter

This chapter contains a checklist for the mechanical and electrical installation of the drive.

Checklist



▲WARNING Obey the safety instructions of the drive. If you ignore them, injury or death, or damage to the equipment can occur. If you are not a qualified electrical professional, do not do electrical installation, commissioning or maintenance work.



▲WARNING Do the steps in [Electrical safety precautions \(page 180\)](#) before you start the work.

Examine the mechanical and electrical installation of the drive before start-up. Do the tasks in the checklist together with a second person.

Make sure that ...	<input checked="" type="checkbox"/>
The ambient operating conditions meet the drive ambient conditions specification and enclosure rating (IP code).	<input type="checkbox"/>
The supply voltage matches the nominal input voltage of the drive. Refer to the type designation label.	<input type="checkbox"/>
The insulation resistance of the input power cable, motor cable, and motor is measured according to local regulations and the manuals of the drive.	<input type="checkbox"/>
The drive cabinet is attached to the floor, and if it is necessary due to vibration etc., also by its top to the wall or roof.	<input type="checkbox"/>
The drive module is fastened properly to the enclosure.	<input type="checkbox"/>

240 Installation checklist

Make sure that ...	<input checked="" type="checkbox"/>
The cooling air can flow freely in and out of the drive. Air recirculation inside the cabinet is not possible (air baffle plates are installed, or there is another air guiding solution).	<input type="checkbox"/>
<u>If the drive is connected to a network other than a symmetrically grounded TN-S system:</u> You have done all the required modifications (for example, you may need to disconnect the EMC filter or ground-to-phase varistor). Refer to the electrical installation instructions in the supply unit manual.	<input type="checkbox"/>
The enclosures of the equipment in the cabinet have proper galvanic connection to the cabinet protective earth (ground) busbar; The connection surfaces at the fastening points are bare (unpainted) and the connections are tight, or separate grounding conductors are installed.	<input type="checkbox"/>
The main circuit connections inside the drive cabinet correspond to the circuit diagrams.	<input type="checkbox"/>
The control unit is connected. Refer to the circuit diagrams.	<input type="checkbox"/>
Appropriate AC fuses and main disconnecting device are installed.	<input type="checkbox"/>
There is an adequately sized protective earth (ground) conductor(s) between the drive and the switchboard, the conductor is connected to correct terminal, and the terminal is tightened to the correct torque. Grounding is measured according to the regulations.	<input type="checkbox"/>
<u>If the drive is equipped with a DC/DC-converter unit:</u> There is an adequately sized protective earth (ground) conductor between the energy storage and the DC/DC-converter, the conductor is connected to the correct terminal, and the terminal is tightened to the correct torque. Proper grounding is measured according to the regulations.	<input type="checkbox"/>
<u>If the drive is equipped with a DC/DC-converter unit:</u> The energy storage cable is connected to the correct terminals of the DC/DC-converter and energy storage, and the terminals are tightened to the correct torque.	<input type="checkbox"/>
<u>If the drive is equipped with a DC/DC-converter unit:</u> The energy storage is equipped with fuses for protecting the energy storage cable in a cable short-circuit situation.	<input type="checkbox"/>
<u>If the drive is equipped with a DC/DC-converter unit:</u> The energy storage is equipped with a disconnecting device.	<input type="checkbox"/>
The input power cable is connected to the correct terminals, the phase order is correct, and the terminals are tightened to the correct torque.	<input type="checkbox"/>
There is an adequately sized protective earth (ground) conductor between the motor and the drive. The conductor is connected to the correct terminal, and the terminal is tightened to the correct torque. Grounding has also been measured according to the regulations.	<input type="checkbox"/>
The motor cable is connected to the correct terminals, the phase order is correct, and the terminals are tightened to the correct torque.	<input type="checkbox"/>
The motor cable is routed away from other cables.	<input type="checkbox"/>
No power factor compensation capacitors are connected to the motor cable.	<input type="checkbox"/>
<u>If an external brake resistor is connected to the drive:</u> There is an adequately sized protective earth (ground) conductor between the brake resistor and the drive, and the conductor is connected to the correct terminal, and the terminals are tightened to the correct torque. Grounding has also been measured according to the regulations.	<input type="checkbox"/>
<u>If an external brake resistor is connected to the drive:</u> The brake resistor cable is connected to the correct terminals, and the terminals are tightened to the correct torque.	<input type="checkbox"/>
<u>If an external brake resistor is connected to the drive:</u> The brake resistor cable is routed away from other cables.	<input type="checkbox"/>
The control cables are connected to the correct terminals, and the terminals are tightened to the correct torque.	<input type="checkbox"/>
<u>If a drive bypass connection will be used:</u> The direct-on-line contactor of the motor and the drive output contactor are either mechanically and/or electrically interlocked, that is, they cannot be closed at the same time. A thermal overload device must be used for protection when bypassing the drive. Refer to local codes and regulations.	<input type="checkbox"/>
There are no tools, foreign objects, or dust from drilling inside the drive.	<input type="checkbox"/>

Make sure that ...	<input checked="" type="checkbox"/>
The area in front of the drive is clean: the drive cooling fan cannot draw any dust or dirt inside.	<input type="checkbox"/>
The terminal box cover of the motor is in place. Cabinet shrouds are in place and doors are closed.	<input type="checkbox"/>
The motor and the driven equipment are ready for power-up.	<input type="checkbox"/>

9

Start-up

Contents of this chapter

This chapter contains the start-up procedure of the inverter.

Note: These instructions do not cover all possible cabinet constructions. Always refer to the delivery-specific circuit diagrams when proceeding with the start-up.



▲WARNING Obey the safety instructions of the drive. If you ignore them, injury or death, or damage to the equipment can occur. If you are not a qualified electrical professional, do not do installation, commissioning, or maintenance work.



Note: The customer is fully responsible for implementing and testing the functional safety circuits according to the relevant legislation and acceptance testing regulations. The functional safety option manuals give examples on implementing the safety circuits in ACS880 multidrives. For information on the Safe torque off function, refer to chapter [The Safe torque off function \(page 389\)](#).









Start-up procedure

Tasks	<input checked="" type="checkbox"/>
Safety	
 ▲WARNING Obey the safety instructions during the start-up procedure. See ACS880 multidrives cabinets and modules safety instructions (3AUA0000102301 [English]) and Electrical safety precautions (page 180) .	<input type="checkbox"/>
Checks/Settings with no voltage connected	
Check the mechanical and electrical installation.	<input type="checkbox"/>
Make sure that the insulation resistance of the assembly has been checked. Refer to Measuring the insulation (page 181) .	<input type="checkbox"/>
The supply unit of the drive system has been set up according to the instructions in its manuals.	<input type="checkbox"/>
The supply unit is off, and the drive system has been isolated from the supply network.	<input type="checkbox"/>
Check that any circuit breakers and protection switches in the cooling fan supply circuit are closed. Refer to the circuit diagrams.	<input type="checkbox"/>
Check the following data for each inverter unit and note down any deviations from delivery documents.	
<ul style="list-style-type: none"> • Motor, pulse encoder and cooling fan rating plate data correspond to the values in the motor list. 	<input type="checkbox"/>
<ul style="list-style-type: none"> • Motor temperature method: Pt100, PTC, KTY84, other? 	<input type="checkbox"/>
<ul style="list-style-type: none"> • Motor fan of separately ventilated motors. Check the current, the overcurrent protection setting and the functioning of the fan output control circuit. 	<input type="checkbox"/>
<ul style="list-style-type: none"> • Direction of motor rotation. 	<input type="checkbox"/>
<ul style="list-style-type: none"> • Maximum and minimum speeds, fixed speeds. 	<input type="checkbox"/>
<ul style="list-style-type: none"> • Speed scaling factor, gear ratio, roll diameter, etc. 	<input type="checkbox"/>
<ul style="list-style-type: none"> • Acceleration and deceleration times. 	<input type="checkbox"/>
<ul style="list-style-type: none"> • Inertia compensation. 	<input type="checkbox"/>
<ul style="list-style-type: none"> • Operating modes, stop mode, emergency stop mode, etc. 	<input type="checkbox"/>
For start-up of the module variant with capability for increased switching frequency (option +P967), see ACS880 multidrive for high-speed test benches supplement (3AXD50000818013 [English]) .	<input type="checkbox"/>
Connecting voltage to the auxiliary circuits	
Disconnect any auxiliary voltage (230 or 115 V AC) cables that lead from the terminal blocks to the outside of the equipment and have not yet been checked. Also disconnect any uncompleted wiring.	<input type="checkbox"/>
Disconnect the communication link between the drive system and any overriding system.	<input type="checkbox"/>
Make sure the main contactor/breaker cannot be switched on inadvertently by remote control.	<input type="checkbox"/>
Be ready to trip the main breaker of the supply transformer in case something abnormal occurs.	<input type="checkbox"/>
Ensure all cabinet doors are closed.	<input type="checkbox"/>
Close the main breaker of the supply transformer. This will energize the input terminals of the drive system.	<input type="checkbox"/>
Close the auxiliary voltage switch (if present).	<input type="checkbox"/>
Checks with auxiliary voltage connected	



Tasks	<input checked="" type="checkbox"/>
Check that the cooling fans rotate freely in the right direction, and the air flows up.	<input type="checkbox"/>
<p>Note:</p> <ul style="list-style-type: none"> Speed-controlled cooling fans of frame R8i modules (ie. without option +C188) will not rotate until the DC voltage to the module is connected. Depending on the wiring of the drive system and the type of inverter modules, it may be necessary to have the supply unit powered before the fans are started. If so, check the cooling fans after powering the supply unit. 	
Set the parameters for each inverter unit. Refer to the firmware manual and/or start-up guide of the control program. You can also use the start-up assistant if available in the particular control program.	
In addition to the parameter settings required by the application, make the following settings:	
<ul style="list-style-type: none"> Set 31.23 Wiring or earth fault to “No action”. 	<input type="checkbox"/>
<ul style="list-style-type: none"> Set 95.04 Control board supply according to how the inverter control unit is powered. 	<input type="checkbox"/>
<ul style="list-style-type: none"> Edit 95.08 DC switch monitoring if necessary (ie. with R1i...R7i modules equipped with a DC switch/disconnector). 	<input type="checkbox"/>
<ul style="list-style-type: none"> Edit 95.09 Fuse switch control if necessary (ie. with R8i modules without a DC switch/disconnector and charging controller). 	<input type="checkbox"/>
<ul style="list-style-type: none"> With R8i modules with option +C188 (direct-on-line cooling fan), set bit 14 of 95.20 HW options word 1. 	<input type="checkbox"/>
<ul style="list-style-type: none"> With parallel-connected R8i modules, select the inverter unit type in parameter 95.31 Parallel connection rating id. You can filter the list using parameter 95.30. 	<input type="checkbox"/>
<ul style="list-style-type: none"> Reboot the control unit either by cycling the power, or by parameter 96.08 Control board boot. <p>Note: Frames R6i and R7i with option +C249 (BCU or UCU-22 control unit) require an additional control board reboot after module is powered up.</p>	<input type="checkbox"/>
Powering up the inverter unit	
Close the cabinet doors.	<input type="checkbox"/>
Make sure that it is safe to connect voltage to the drive system. Ensure that: <ul style="list-style-type: none"> nobody is working on the unit or circuits that have been wired from outside into the cabinets cover of the motor terminal box is on. 	<input type="checkbox"/>
Close the main disconnecting device of the drive system.	<input type="checkbox"/>
 <p>▲WARNING When connecting voltage to the supply unit, the DC busbars will become live, as will all the inverters connected to the DC bus.</p>	
 <p>▲WARNING <u>Inverter units with a DC switch-disconnector:</u> If you want to keep the inverter modules de-energized at the drive power up, make sure that DC switch disconnector is open. Make sure that the charging switch is open.</p> <p><u>Inverter units without a DC switch-disconnector:</u> If the inverter unit only has DC fuses without a switch fuse, all the inverter units with the DC fuses in place will be energized when the main breaker/contacter closes. To prevent this, remove the fuses from the inverter units which are to remain unenergized before connecting voltage. When the main breaker/contacter of the supply unit is closed (DC busbars are live), never remove or insert the DC fuses of an inverter unit.</p> <p><u>Inverter cubicles with frame R1i...R5i modules:</u> Before closing the main DC switch-disconnector of the cubicle, leave open the fuse disconnectors of those inverter modules that need not be powered at this time. Do not open or close any fuse disconnectors under load.</p>	
<u>Inverter units equipped with DC switch-disconnector (or fuse disconnectors):</u> Close the DC switch/disconnector (or fuse disconnectors) of the inverter units that are to be powered up.	<input type="checkbox"/>
<u>Inverter cubicles equipped with main DC switch-disconnector (frames R1i...R5i):</u> Close the main DC switch/disconnector.	<input type="checkbox"/>



Tasks	<input checked="" type="checkbox"/>
 ▲WARNING Before closing the main contactor/air circuit breaker, make sure that sufficient inverter power is connected to the intermediate (DC) bus. As a rule of thumb, <ul style="list-style-type: none"> • the sum power of the inverters connected must be at least 30% of the sum power of all inverters • the sum power of the inverters connected must be at least 30% of the rated power of the brake unit (Pbr.max) (if present). If the above-mentioned rules are not followed, the DC fuses of the connected inverter units may blow, or the brake chopper (if present) may be damaged.	<input type="checkbox"/>
Close the main contactor (or breaker) of the supply unit. The DC bus is now powered, along with all inverters that are connected to it.	<input type="checkbox"/>
Checks with voltage connected to the inverter unit	
Complete the pending ID (motor identification) run. Refer to the firmware manual and/or start-up guide of the control program.	<input type="checkbox"/>
 ▲WARNING Make sure the motor can be started and rotated as required by the selected ID run mode (parameter 99.13 ID run requested).	
Check the rotation direction of the motor.	<input type="checkbox"/>
Check the operation of the pulse encoder (if present). Refer to the user manual of the pulse encoder interface module.	<input type="checkbox"/>
Check the functioning of the emergency stop function from each operating location.	<input type="checkbox"/>
Validate the Safe torque off function. Refer to chapter The Safe torque off function , section Start-up including validation test (page 404).	<input type="checkbox"/>
  ▲WARNING The safety functions cannot be considered safe until they are validated.	
Validate any other safety functions (Emergency stop, Prevention of unexpected start-up, etc.) according to the appropriate procedures.	<input type="checkbox"/>
  ▲WARNING The safety functions cannot be considered safe until they are validated.	
Control from an overriding system	
Disconnect all voltages from the drive system.	<input type="checkbox"/>
Connect the communication link between the overriding system and the inverter unit.	<input type="checkbox"/>
Power up the drive system.	<input type="checkbox"/>
Check the start/stop functions.	<input type="checkbox"/>
Check the references received from the overriding system.	<input type="checkbox"/>
Check the warning/fault words.	<input type="checkbox"/>
Check the reaction of the inverter unit in case of a communication break.	<input type="checkbox"/>
Check the updating intervals of the communication.	<input type="checkbox"/>
Check any other relevant points.	<input type="checkbox"/>

Charging sequence

Frame R8i and multiples: For details on charging sequence, refer to [BSFC-02C and BSFC-12C charging controllers hardware manual \(3AXD50000027498 \[English\]\)](#).

10

Maintenance

Contents of this chapter

This chapter contains maintenance instructions.

Maintenance intervals

The tables show the maintenance tasks that can be done by the end user. For the ABB Service offering, contact your local ABB Service representative (new.abb.com/contact-centers).

■ Description of symbols

Action	Description
I	Inspection (visual inspection and maintenance action if needed)
P	Performance of on/off-site work (commissioning, tests, measurements or other work)
R	Replacement

■ Recommended maintenance intervals after start-up

Maintenance task/object	Years from start-up													
	0	1	2	3	4	5	6	7	8	9	10	11	12	...
Cooling														
Inverter module main cooling fan										R				
Frame R5i auxiliary cooling fan										R				
Frame R8i circuit board compartment fan										R				
Cabinet cooling fan (50 Hz)										R				
Cabinet cooling fan (60 Hz)							R						R	
Batteries														
Control unit battery							R						R	
Control panel battery										R				
Connections and environment														
Air inlet and outlet cleaning (IP22/IP42)		I	I	I	I	I	I	I	I	I	I	I	I	I
Cabinet door filter change (IP54)		R	R	R	R	R	R	R	R	R	R	R	R	R
Checking tightness of cable and busbar terminals. Tightening if needed.		I	I	I	I	I	I	I	I	I	I	I	I	I
Checking ambient conditions (dustiness, corrosion, temperature)		I	I	I	I	I	I	I	I	I	I	I	I	I
Cleaning of heatsinks		I	I	I	I	I	I	I	I	I	I	I	I	I
Quality of supply voltage		P	P	P	P	P	P	P	P	P	P	P	P	P
Spare parts														
Spare parts		I	I	I	I	I	I	I	I	I	I	I	I	I
DC circuit capacitor reforming (spare modules and spare capacitors)		P	P	P	P	P	P	P	P	P	P	P	P	P
Functional safety														
Safety function test	I See the maintenance information of the safety function.													
Safety component expiry (Mission time, T_M)	20 years													
4FPS10000292961														

Note:

- The maintenance and component replacement intervals are valid when the equipment operates within the specified ratings and ambient conditions. ABB recommends annual drive inspections.
- Long-term operation near the specified maximum ratings or ambient conditions may require shorter maintenance intervals for certain components. Contact your local ABB Service representative for additional maintenance recommendations.

Maintenance timers and counters

The control program has maintenance timers and counters that can be configured to generate a warning when a pre-defined limit is reached. Each timer/counter can be set to monitor any parameter. This feature is especially useful as a service reminder. For more information, refer to the firmware manual.

Cleaning

■ Cleaning the interior of the cabinet



▲WARNING Obey the safety instructions of the drive. If you ignore them, injury or death, or damage to the equipment can occur. If you are not a qualified electrical professional, do not do electrical installation, commissioning or maintenance work.

NOTICE Use an antistatic wrist strap and a vacuum cleaner with an antistatic hose and nozzle. A normal vacuum cleaner creates static discharges which can cause damage to circuit boards.

1. Stop the drive and do the steps in [Electrical safety precautions \(page 180\)](#) before you start the work.
2. Open the cabinet door.
3. Clean the interior of the cabinet. Use a vacuum cleaner and a soft brush.
4. Clean the air inlets of the fans and air outlets of the modules (top).
5. Clean the air inlet gratings (if any) on the door.
6. Close the door.

■ Cleaning the heatsink

The heatsink of the power module (drive, supply, inverter, converter, and so on) collects dust from the cooling air. This can cause overtemperature warnings and faults. When it is necessary, clean the heatsink as follows.



▲WARNING Obey the safety instructions of the drive. If you ignore them, injury or death, or damage to the equipment can occur. If you are not a qualified electrical professional, do not do electrical installation, commissioning or maintenance work.



▲CAUTION Use the required personal protective equipment. Wear protective gloves and long sleeves. Some parts have sharp edges.

1. Stop the drive and do the steps in [Electrical safety precautions \(page 180\)](#) before you start the work.
2. Remove the module cooling fan(s). Refer to the separate instructions.
3. Protect the adjacent equipment from dust.
4. Blow dry, clean, and oil-free compressed air from the bottom to the top, and simultaneously use a vacuum cleaner at the air outlet to collect the dust.

NOTICE Use an antistatic wrist strap and a vacuum cleaner with an antistatic hose and nozzle. A normal vacuum cleaner creates static discharges which can cause damage to circuit boards.

5. Install the cooling fan.

■ **Cleaning the door air inlets**

Follow the instructions of the manufacturer of the cabinet system.

Cleaning the door air inlets (IP20)

Use a vacuum cleaner and brush to clean the grating.

Cleaning the door air inlets (IP22 and IP42)

Check the dustiness of the air inlet meshes. If the dust cannot be removed by vacuum cleaning from outside through the grating holes with a small nozzle, proceed as follows:

1. Stop the drive and do the steps in [Electrical safety precautions \(page 180\)](#) before you start the work.
2. Remove the fasteners at the top of the grating.
3. Lift the grating and pull it away from the door.
4. Vacuum clean or wash the grating on both sides.
5. Reinstall the grating in reverse order.

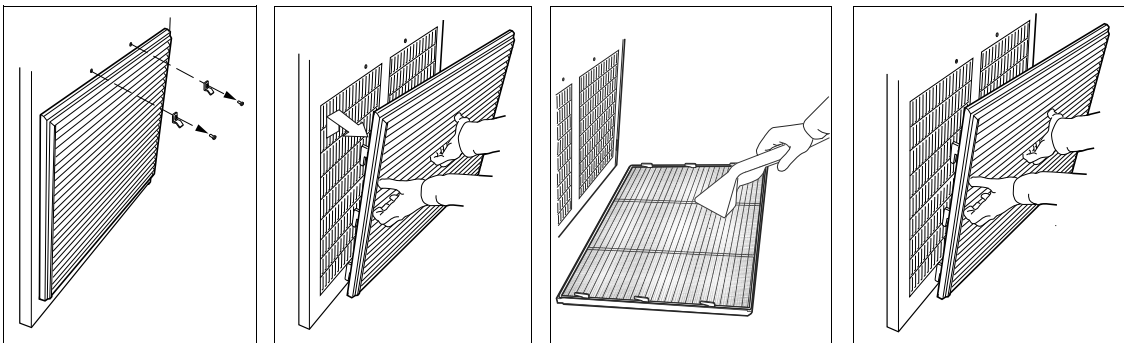

Replacing the inlet door filters (IP54)

1. Stop the drive and do the steps in [Electrical safety precautions \(page 180\)](#) before you start the work.
2. Remove the fasteners at the top of the grating.
3. Lift the grating and pull it away from the door.
4. Remove the air filter mat.
5. Place the new filter mat in the grating the metal wire side facing the door.
6. Reinstall the grating in reverse order.

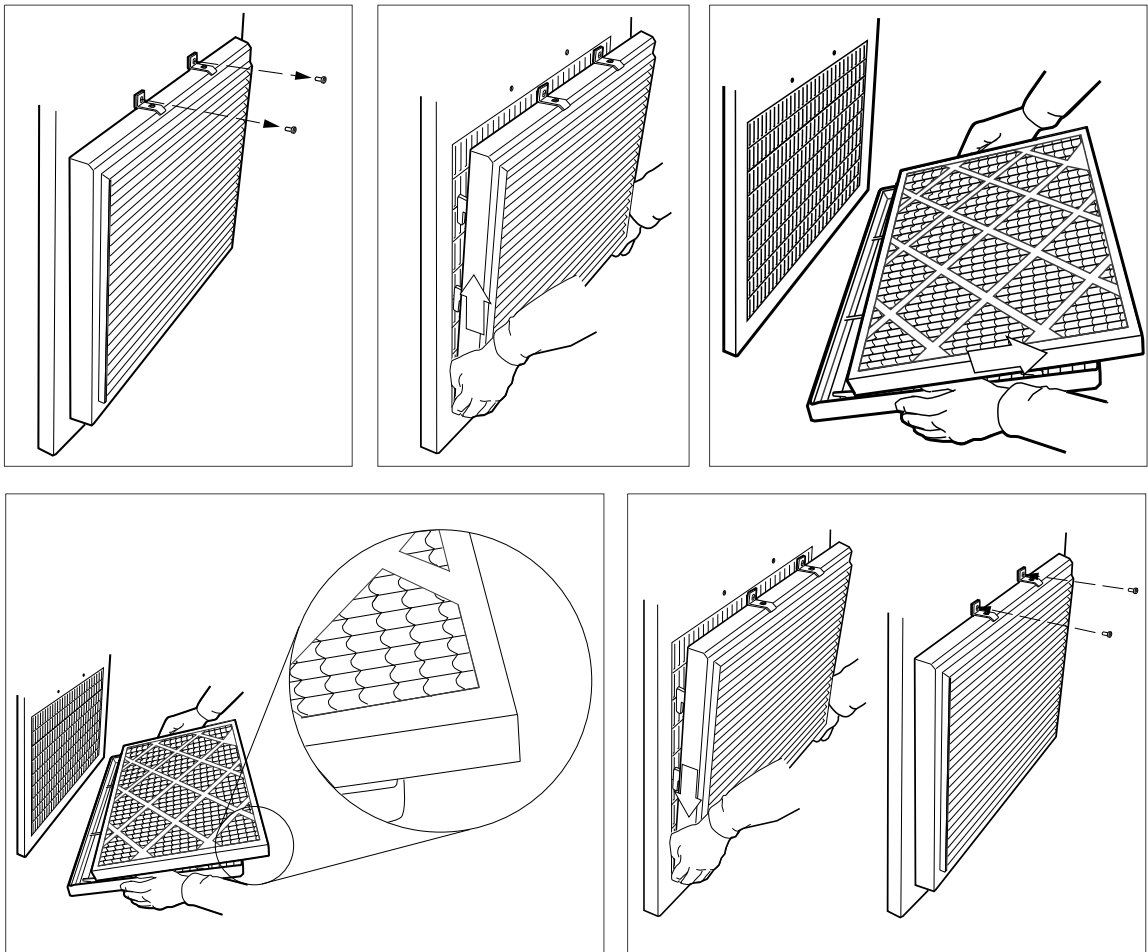

Cooling fans

The lifespan of the cooling fans of the drive depends on running time, ambient temperature and dust concentration. Refer to the firmware manual for the actual signal which indicates the running time of the cooling fan. Reset the running time signal after fan replacement.

Replacement fans are available from ABB. Do not use other than ABB-specified spare parts.

■ Replacing the module cooling fans

Replacing the R1i and R2i module cooling fan



▲WARNING Obey the safety instructions of the drive. If you ignore them, injury or death, or damage to the equipment can occur. If you are not a qualified electrical professional, do not do installation, commissioning, or maintenance work.

1. Stop the drive and do the steps in [Electrical safety precautions \(page 180\)](#) before you start the work.
2. Detach the power cable clamp plate and terminal blocks.
3. Release the retaining clips (arrowed) carefully using a screwdriver.
4. Pull the fan holder out.
5. Disconnect the fan cable.
6. Carefully bend the clips on the fan holder to free the fan.
7. Install new fan in reverse order.

Note: The airflow direction is bottom-to-top. Install the fan so that the arrow on it points up.

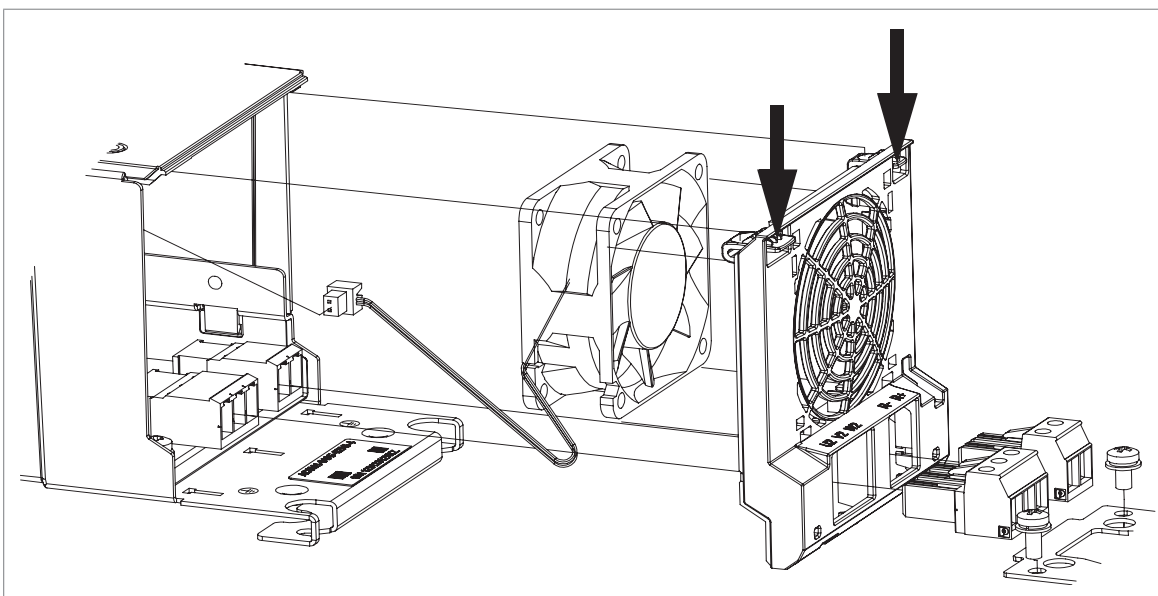

In the drawing, the direction of airflow is from right to left.

Replacing the R3i and R4i module cooling fan



▲WARNING Obey the safety instructions of the drive. If you ignore them, injury or death, or damage to the equipment can occur. If you are not a qualified electrical professional, do not do installation, commissioning, or maintenance work.

1. Stop the drive and do the steps in [Electrical safety precautions \(page 180\)](#) before you start the work.
2. To remove the fan, release the retaining clip (arrowed) carefully using a screwdriver.
3. Pull the fan holder out.
4. Disconnect the fan cable.
5. Carefully bend the clips on the fan holder to free the fan.
6. Install new fan in reverse order.

Note: The airflow direction is bottom-to-top. Install the fan so that the airflow arrow points up.

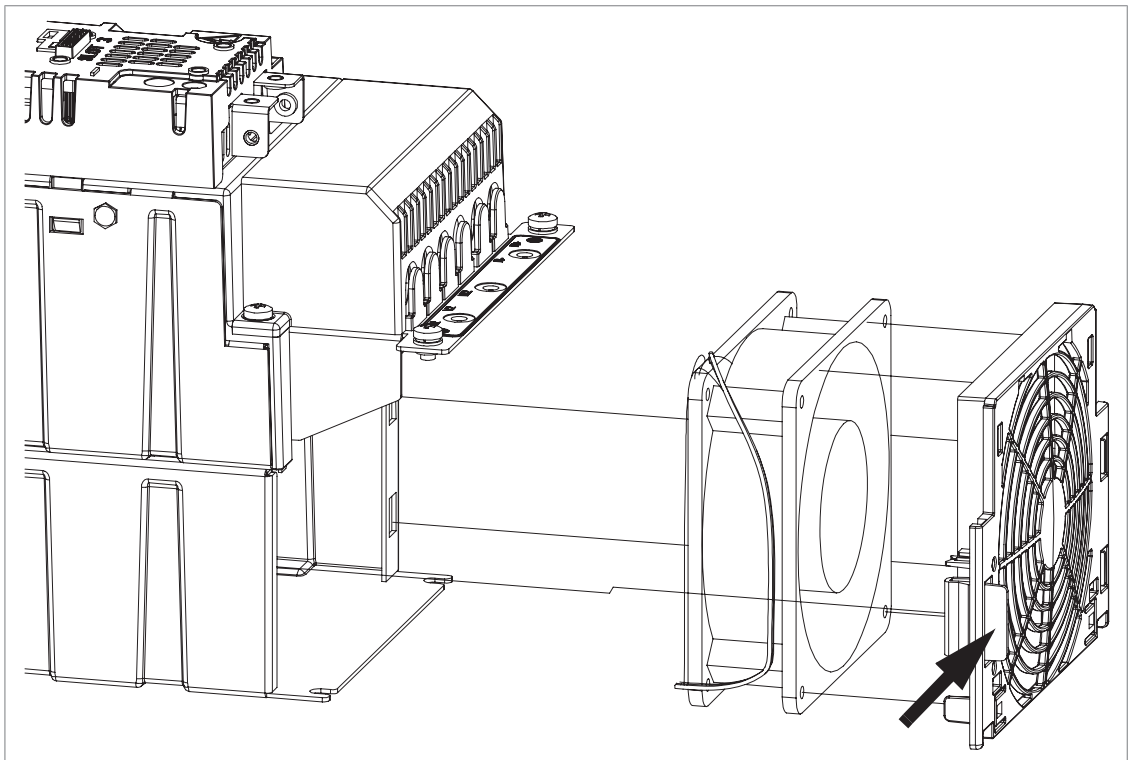

In the picture direction of airflow is from right to left.

Replacing the R5i module main cooling fan



⚠ WARNING Obey the safety instructions of the drive. If you ignore them, injury or death, or damage to the equipment can occur. If you are not a qualified electrical professional, do not do installation, commissioning, or maintenance work.

1. Stop the drive and do the steps in section [Electrical safety precautions \(page 180\)](#) before you start the work.
2. Disconnect the drive from the power line. Lock the main disconnecting device and ensure by measuring that there is no voltage.
3. Lift the fan mounting plate by the front edge.
4. Unplug the power supply wires.
5. Lift the fan assembly off.
6. Install the new fan assembly in reverse order. Make sure that the fan blows up.



Replacing the R5i module auxiliary cooling fan

Frame R5i modules have an auxiliary fan located at the top front of the module.



▲WARNING Obey the safety instructions of the drive. If you ignore them, injury or death, or damage to the equipment can occur. If you are not a qualified electrical professional, do not do installation, commissioning, or maintenance work.

1. Stop the drive and do the steps in [Electrical safety precautions \(page 180\)](#) before you start the work.
2. Disconnect the fan from the control unit. Make note of the connector the plug is connected to.
3. Push the two locking tabs gently inwards to release the fan.
4. Remove the fan.
5. Install new fan in reverse order. Make sure that the fan blows up (the arrows on the fan frame and the fan holder point in the same direction).

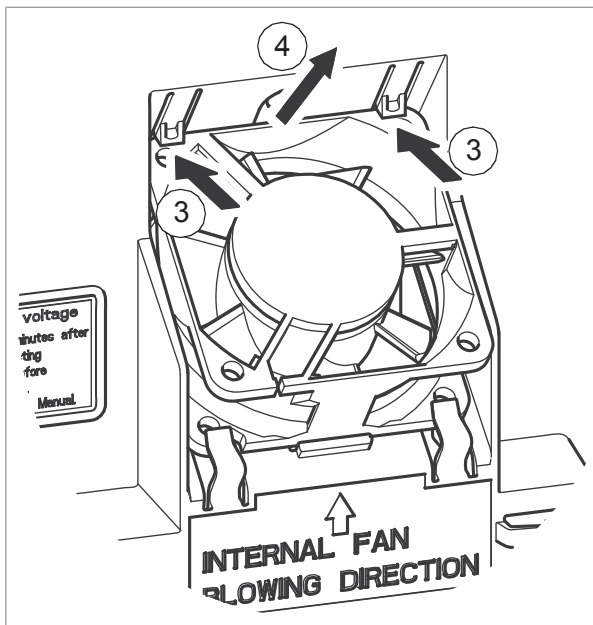

Replacing the R6i and R7i module cooling fan

Frame R6i module has one fan, R7i module has two.



▲WARNING Obey the safety instructions of the drive. If you ignore them, injury or death, or damage to the equipment can occur. If you are not a qualified electrical professional, do not do installation, commissioning, or maintenance work.



▲WARNING Use the required personal protective equipment. Wear protective gloves and long sleeves. Some parts have sharp edges.

1. Stop the drive and do the steps in [Electrical safety precautions \(page 180\)](#) before you start the work.
2. Open the door. Remove any shrouding in front of the fan unit.
3. Remove the front plate.
4. Remove the two screws that lock the fan unit.
5. Disconnect the power supply wire(s) of the fan(s).
6. To free the fan holder, pull it slightly outwards (about 5 mm), then downwards.
7. Remove the fan(s) from the fan holder.
8. Install new fan(s) in reverse order to the above.

Note: The airflow direction is bottom-to-top. Make sure that the airflow direction arrow on the fan points up.

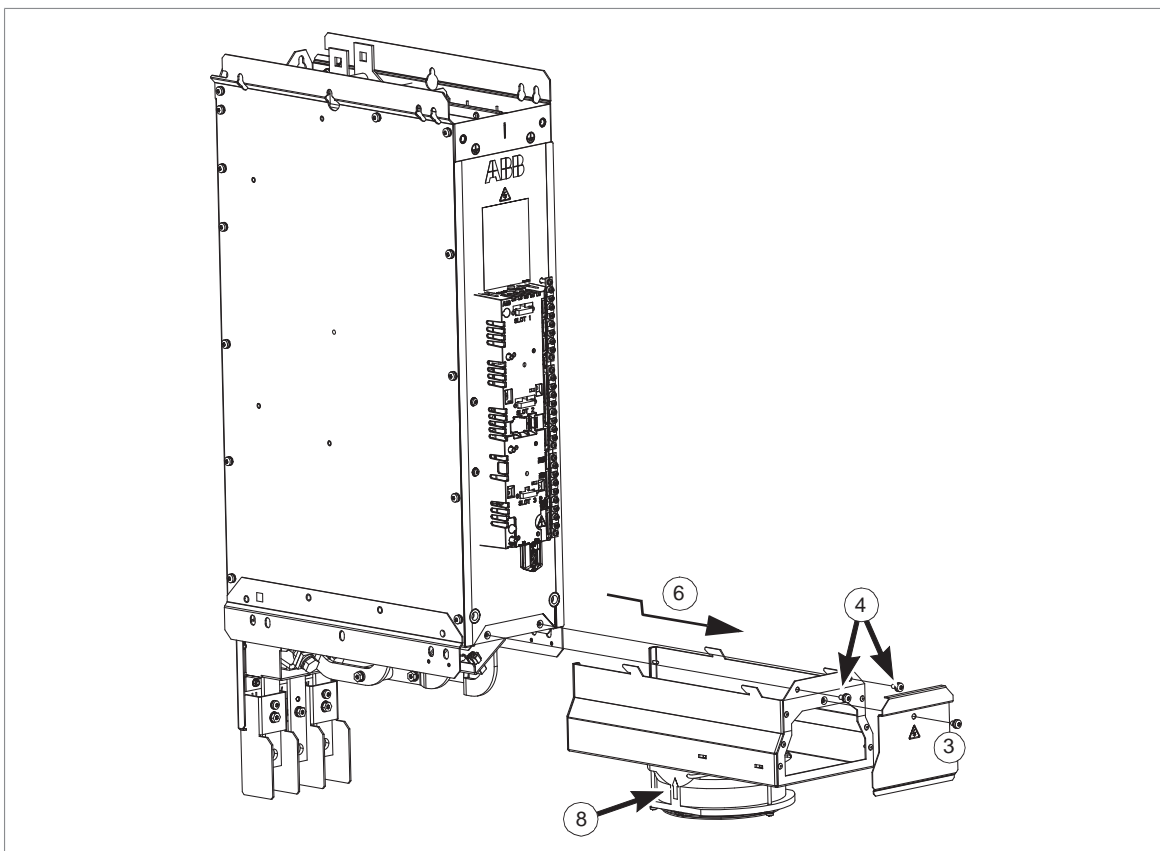

Replacing R8i module cooling fan (speed-controlled version)

The module is equipped with a fan unit that contains two cooling fans.



▲WARNING Obey the safety instructions of the drive. If you ignore them, injury or death, or damage to the equipment can occur. If you are not a qualified electrical professional, do not do electrical installation, commissioning or maintenance work.



▲CAUTION Use the required personal protective equipment. Wear protective gloves and long sleeves. Some parts have sharp edges.

Before you start replacing the fan kit of the converter module, make sure that the connector at the end of the fan kit cable is compatible with the counterpart in the module. Black connector is compatible only with the black counterpart, and gray connector only with the gray counterpart. If the connectors are not compatible, replace the connector at the end of the fan kit cable. Use the connector in the old fan kit, or order a suitable connector from ABB.

1. Stop the drive and do the steps in [Electrical safety precautions \(page 180\)](#) before you start the work.
2. Open the cubicle door.
3. Remove the shroud in front of the fan (if any).
4. Remove the screws holding the front cover plate. Lift the cover plate somewhat to release it.
5. Disconnect the fan wiring.
6. Remove the unit below the fan.
7. Remove the screws of the fan unit.
8. Pull out the fan unit.
9. Install a new fan in reverse order.

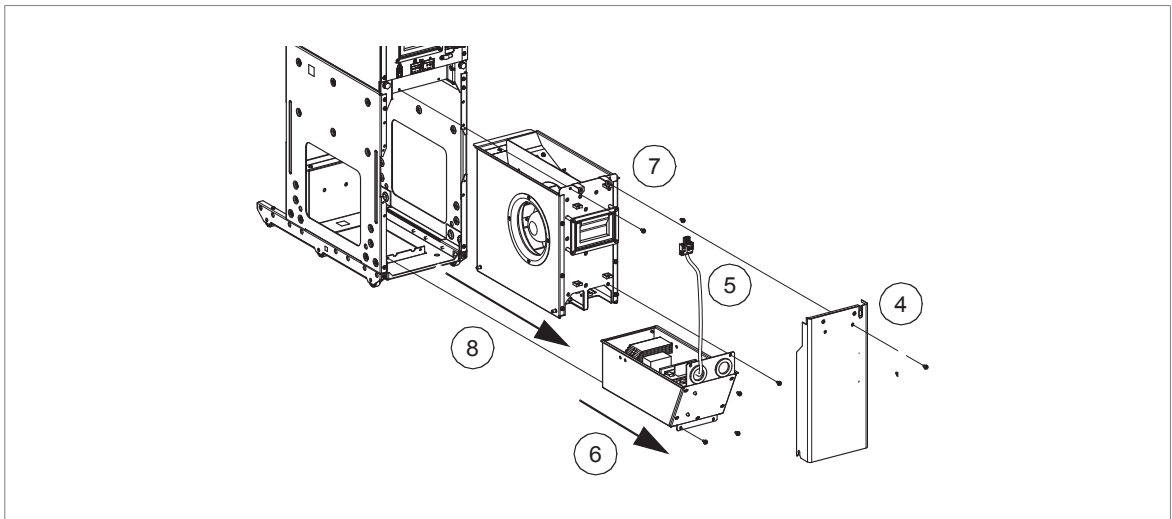

Replacing R8i module cooling fan (direct-on-line version, option +C188)



▲WARNING Obey the safety instructions of the drive. If you ignore them, injury or death, or damage to the equipment can occur. If you are not a qualified electrical professional, do not do electrical installation, commissioning or maintenance work.



▲CAUTION Use the required personal protective equipment. Wear protective gloves and long sleeves. Some parts have sharp edges.

Before you start replacing the fan kit of the converter module, make sure that the connector at the end of the fan kit cable is compatible with the counterpart in the module. Black connector is compatible only with the black counterpart, and gray connector only with the gray counterpart. If the connectors are not compatible, replace the connector at the end of the fan kit cable. Use the connector in the old fan kit, or

order a suitable connector from ABB. Refer to [Connector replacement guide for ACS880-x04 R8i/D8T, BLCL-2X, BL-2X and BLHF DOL fan \(3AXD50001059903 \[English\]\)](#).

1. Stop the drive and do the steps in [Electrical safety precautions \(page 180\)](#) before you start the work.
 2. Open the door.
 3. Remove the shroud in front of the fan (if any).
 4. Remove the screws holding the front cover plate. Lift the cover plate somewhat to release it.
 5. Remove the bracket.
 6. Disconnect the wiring of the fan unit.
 7. Remove the screws of the fan unit.
 8. Pull out the fan unit.
 9. Disconnect the fan wire from the fan unit.
 10. Remove the screws of the fan.
 11. Install a new fan in reverse order.
-

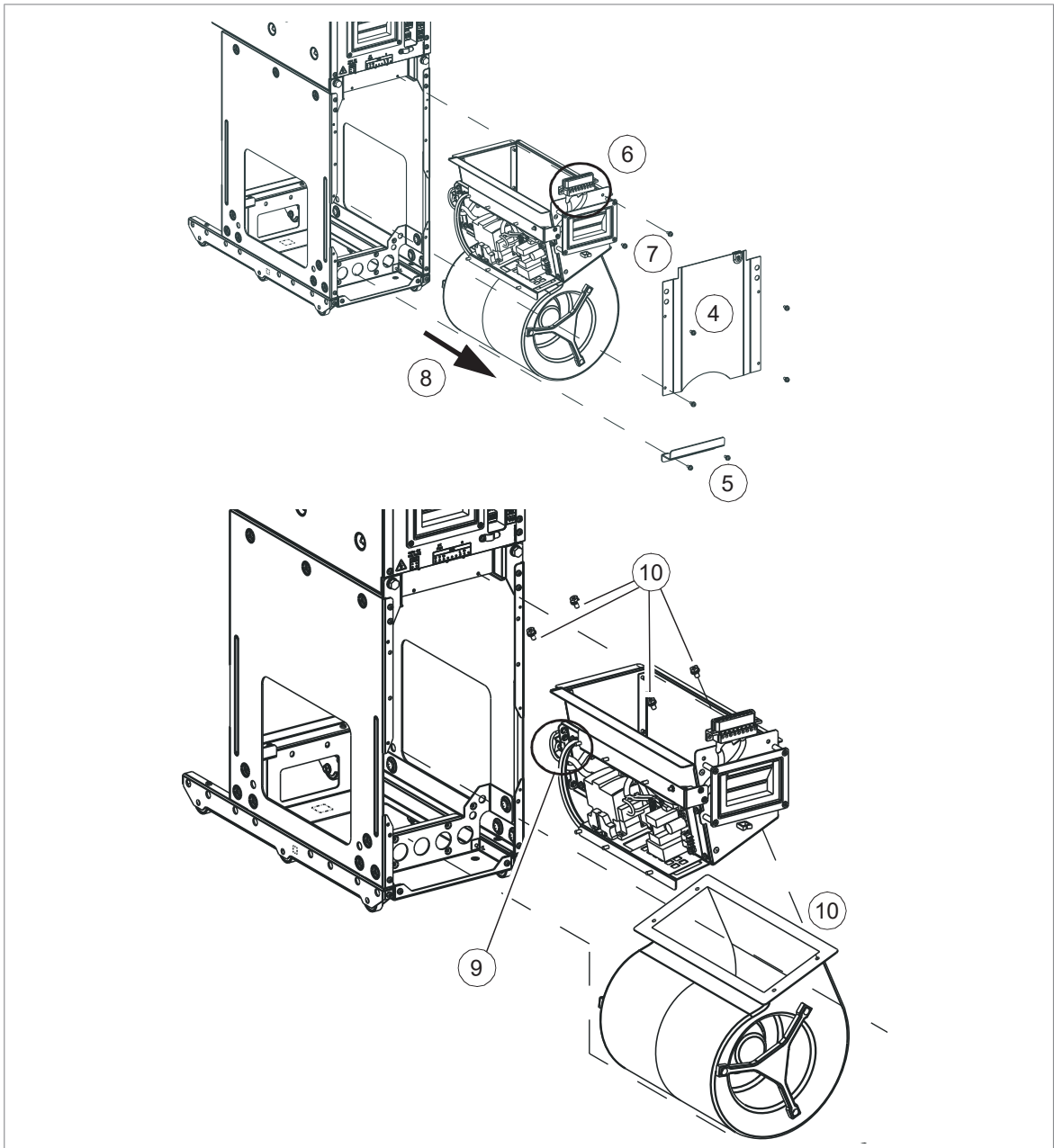

Replacing the circuit board compartment fan

Frame R8i modules are equipped with a fan blowing air through the circuit board compartment.

The fan is accessible from the front of the module.



▲WARNING Obey the safety instructions of the drive. If you ignore them, injury or death, or damage to the equipment can occur. If you are not a qualified electrical professional, do not do electrical installation, commissioning or maintenance work.

1. Stop the drive and do the steps in [Electrical safety precautions \(page 180\)](#) before you start the work.
2. Open the door of the module cubicle.
3. Remove the two M4×12 (T20) screws that lock the fan holder.

4. Pull the fan holder out of the module.
5. Disconnect the fan cable.

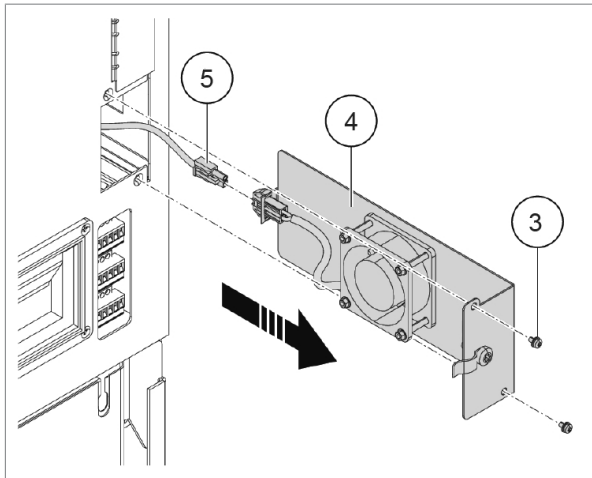

6. Remove the four M3 (5.5 mm) nuts that hold the fan.
7. Remove the fan from the fan holder.

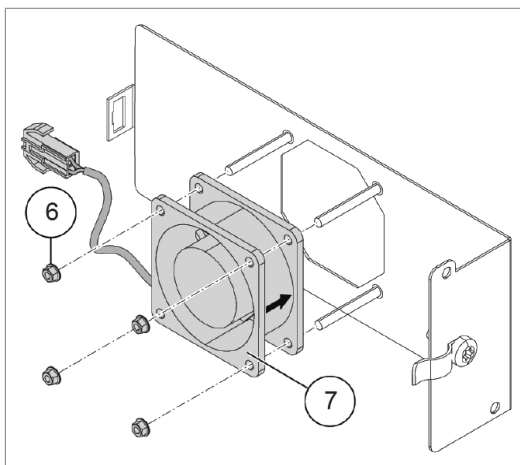

8. Put the fan onto the threaded studs on the fan holder with the airflow direction arrow pointing towards the fan holder.
9. Install and tighten the four nuts removed earlier.

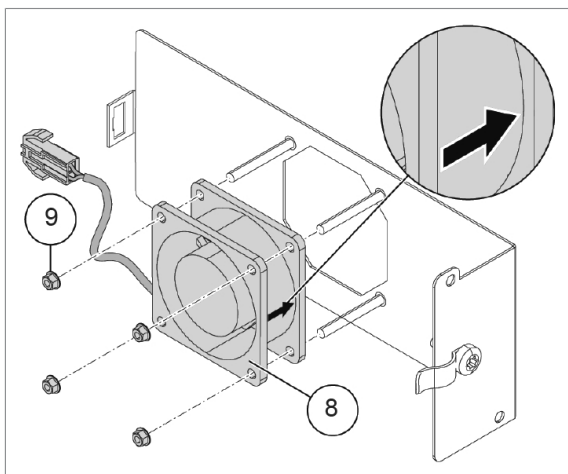

10. Connect the fan cable.
11. Align and push the fan holder into the module.
12. Install and tighten the two M4×12 (T20) screws.

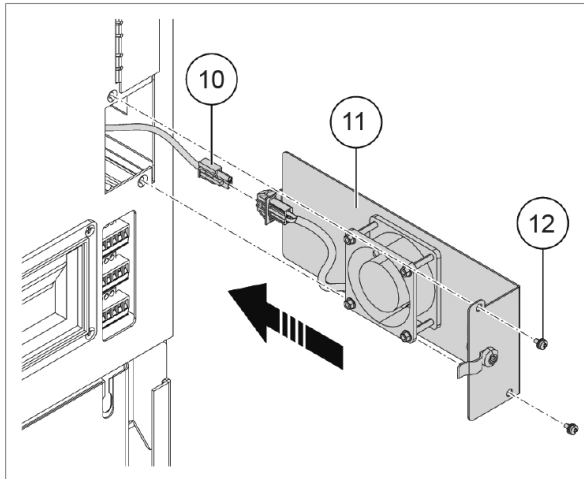

■ Replacing the cabinet cooling fans

Cabinets with ABB air outlet kits



▲WARNING Obey the safety instructions of the drive. If you ignore them, injury or death, or damage to the equipment can occur. If you are not a qualified electrical professional, do not do installation, commissioning, or maintenance work.

1. Stop the drive and do the steps in section [Electrical safety precautions \(page 180\)](#) before you start the work.
2. Remove all gratings and filters, and finally remove the plate on top of the outlet. Unscrew all necessary screws securing the fan and remove it. There are several outlet air kit designs available. Refer to the Ordering info chapter. The assembly drawings for each kit are available from ABB or directly from <https://sites-apps.abb.com/sites/lvacdrivesengineeringsupport/content>.
3. Install new fan in reverse order.

Cabinets with other fan types



▲WARNING Obey the safety instructions of the drive. If you ignore them, injury or death, or damage to the equipment can occur. If you are not a qualified electrical professional, do not do installation, commissioning, or maintenance work.

1. Stop the drive and do the steps in section [Electrical safety precautions \(page 180\)](#) before you start the work.
2. Follow the instructions of the manufacturer of the air outlet or enclosure system.

Replacing R6i/R7i module

The following procedure describes the replacement of a frame R6i or R7i inverter module.

The procedure applies to the design presented in this manual.



▲WARNING Obey the safety instructions of the drive. If you ignore them, injury or death, or damage to the equipment can occur. If you are not a qualified electrical professional, do not do installation, commissioning, or maintenance work.

Refer to the drawings below.

1. Stop the drive and do the steps in section [Electrical safety precautions \(page 180\)](#) before you start the work.
 2. Disconnect the drive system from the AC power line.
 3. Open the cubicle door.
 4. Remove the shrouds. Also remove the mounting brackets of the middle shroud (3a) on the left.
 5. Remove the two screws holding the fan unit (arrowed). Remove the fan unit by pulling it slightly outwards, then downwards.
 6. Remove the mounting screws (arrowed) of the front air baffle. Remove the baffle.
 7. Disconnect all control cabling coming to the control unit at the front of the module. Move the cabling aside and tie it out of the way.
 8. Disconnect the DC busbars.
 9. Disconnect the AC busbars.
 10. Pull out the module until the lifting device (or a suitable hoist) can be attached to the lifting eyes at the top of the module (arrowed).
 11. Make sure the lifting device is carrying the weight of the module, and pull the module out completely.
 12. Install the new module in reverse order to the above.
-

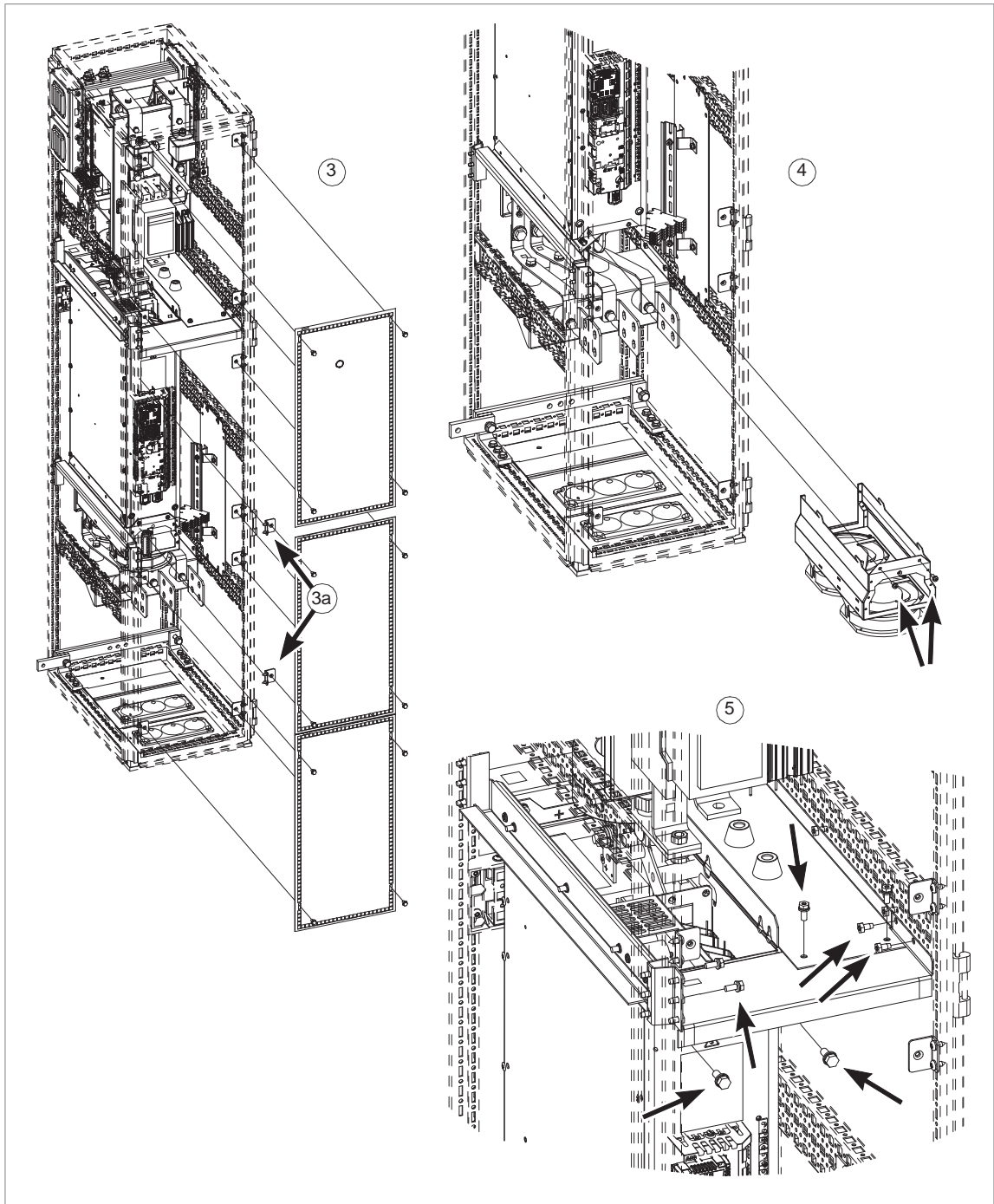

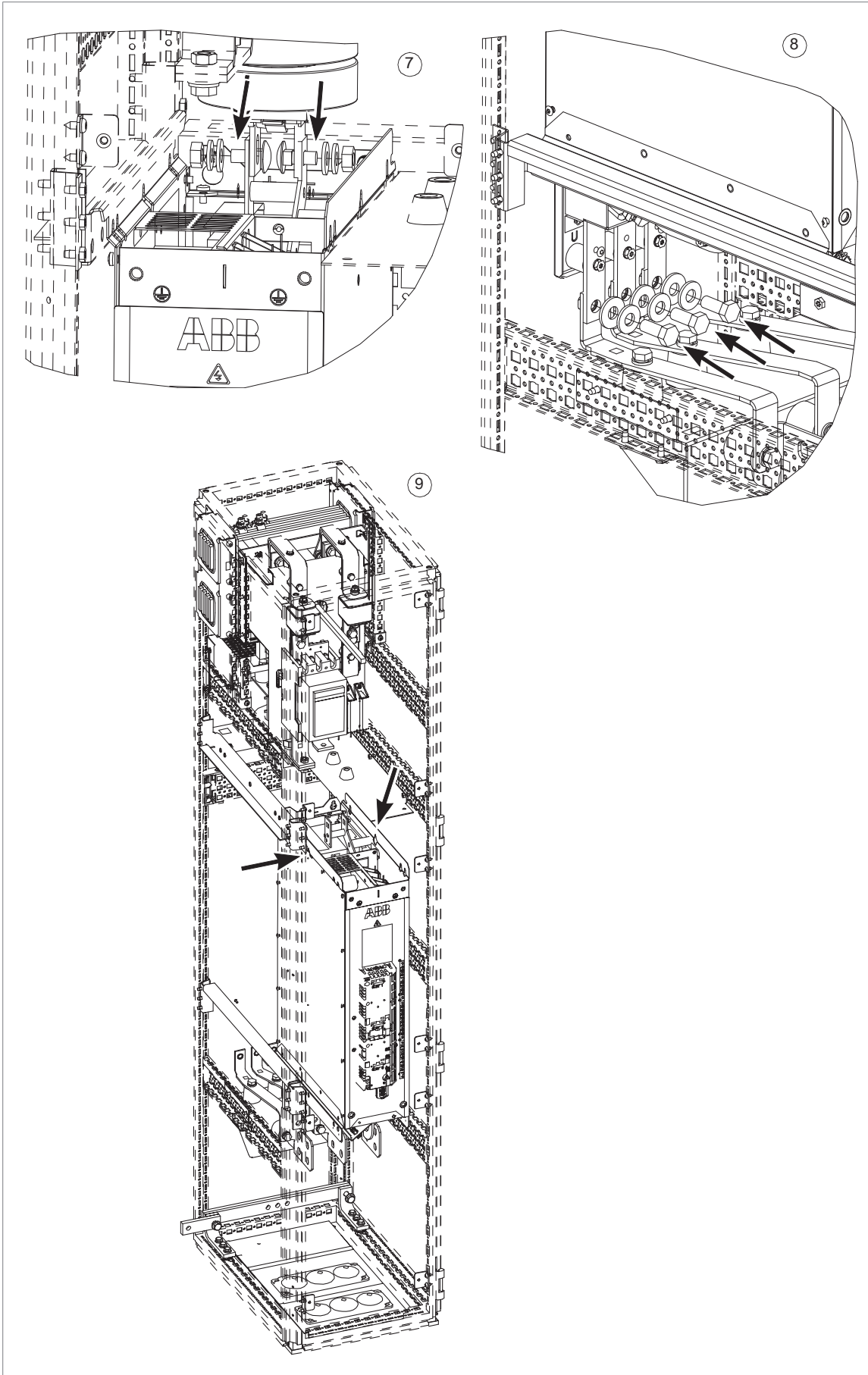

Replacing R8i module





⚠WARNING Obey the safety instructions of the drive. If you ignore them, injury or death, or damage to the equipment can occur. If you are not a qualified electrical professional, do not do installation, commissioning, or maintenance work.

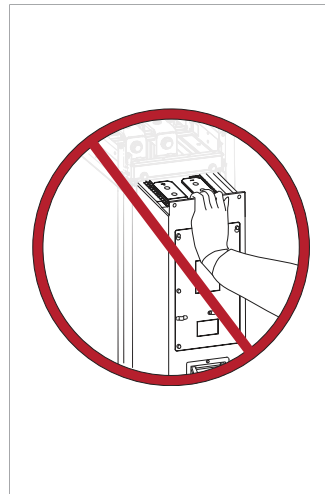
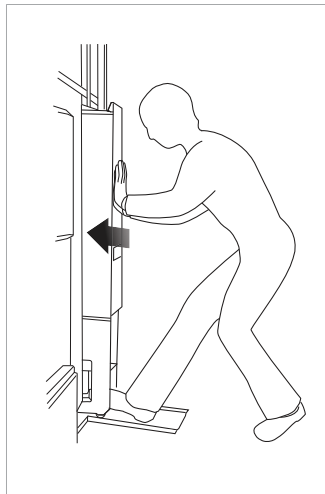
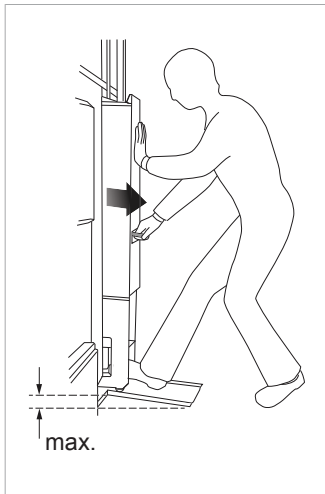

WARNING

- Do not use the module extraction/installation ramp when the height of the drive cabinet plinth is more than the maximum permitted height.
- Secure the module extraction/installation ramp carefully.
- Push the module into the cabinet and pull it from the cabinet carefully preferably with help from another person. Keep a constant pressure with one foot on the base of the module to prevent the module from falling on its back. Keep your fingers away from the edges of the front flange of the module.



-  **CAUTION** Do not move the module on its wheels for long distances. It can cause damage to the wheels. Also, there is a risk of the module falling over.

- Be careful when handling a tall module. The module overturns easily because it is heavy and has a high center of gravity. Whenever possible, secure the module with chains. Do not leave an unsupported module unattended especially on a sloping floor.



- Wear protective gloves and long sleeves! Some parts have sharp edges.

Note: Before you start replacing the supply module, make sure that the connector at the end of the auxiliary power supply cable in the cabinet is compatible with the counterpart in the module. Black connector is compatible only with the black counterpart, and gray connector only with the gray counterpart. If the connectors are not compatible, replace the connector in the new module. Use the connector in the old module, or order suitable connector from ABB. Refer to [+V112 connector replacement guide for ACS880-x04 R8i/D8T/D7T module change \(3AXD50001060015 \[English\]\)](#).

1. Stop the drive and do the steps in section [Electrical safety precautions \(page 180\)](#) before you start the work.
 2. Open the cubicle door.
 3. Remove the shrouds (if any).
 4. Unplug the wiring on the front of the module. Unplug the connector (X50) at the top of the module. Move the wires aside.
 5. Use a module pull out ramp or other lifting device to remove the module from the cabinet. If the ramp designed for Rittal enclosures is used, install it by placing the hooks of the ramp between the bottom plate and enclosure frame.
 6. Remove the two fastening bolts in the DC output busbars. Remove the two fastening screws on the top part of the module.
 7. Remove the module fastening screws on the lower part of the module.
 8. Pull the module carefully out of the cabinet along the ramp, or use another lifting device to remove the module.
 9. Replace the module:
 - Push the module back in and fasten. Tighten the fastening screws of the module to 22 N·m (16.2 lbf·ft) and fastening bolts of the DC input busbars to 70 N·m (51.6 lbf·ft).
 - Reconnect connector X50 at the top of the module.
 - Reconnect the wiring and fiber optic cables to their respective terminals on the front of the module.
 - Remove the module pull-out ramp, attach the shrouds (if any) and close the cabinet doors.
-

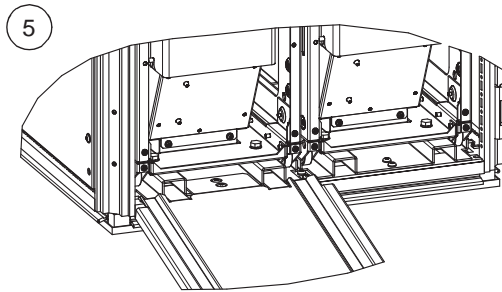
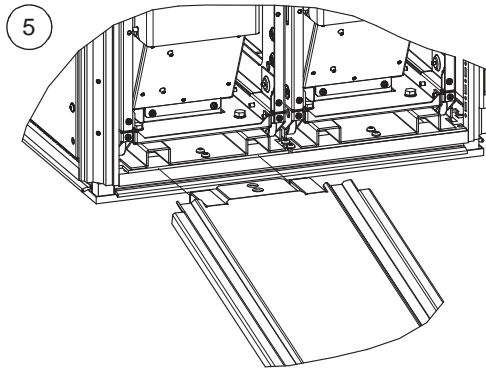
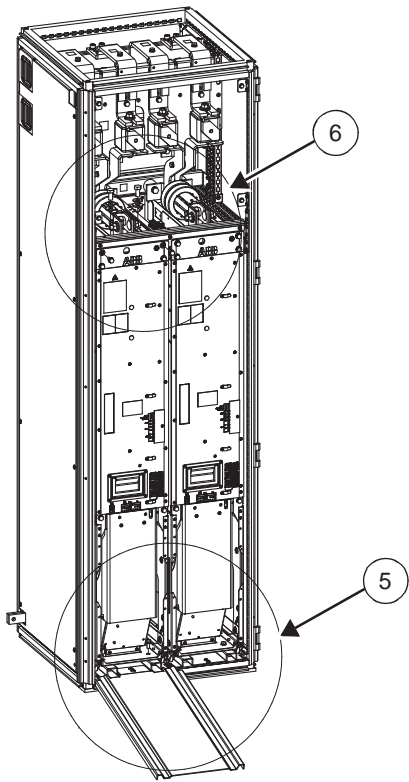

8

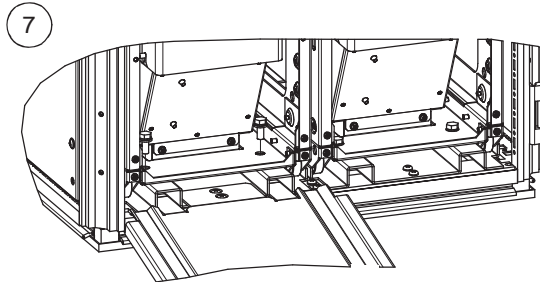
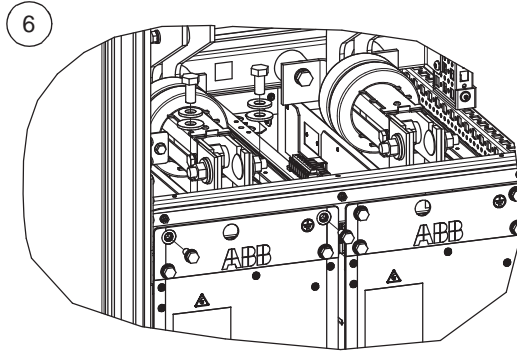
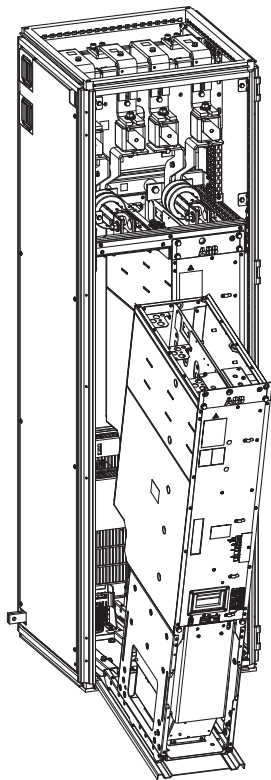

BLHF filters

For maintenance of BLHF filter, see [ACS880 multidrive for high-speed test benches supplement \(3AXD50000818013 \[English\]\)](#).

Capacitors

The intermediate DC circuit of the drive contains several electrolytic capacitors. The operating time, load, and surrounding air temperature have an effect on the operating life of these capacitors. A lower ambient temperature can increase the operating life of capacitors.

Capacitor failure can cause damage to the unit, an input cable fuse failure, or a fault trip. If you think that any capacitors in the drive have failed, contact ABB.

■ Reforming the capacitors

Reform the capacitors if the drive was not powered for a year or more (is in storage or is unused). Read the manufacturing date from the type designation label. For the instructions, refer to [Capacitor reforming instructions \(3BFE64059629 \[English\]\)](#).

Control units

■ UCU and BCU control units

For the maintenance instructions of a UCU or BCU control unit, refer to the applicable hardware manual:

- [UCU-22...24 control units hardware manual \(3AXD50000817726 \[English\]\)](#).
- [BCU-02, BCU-12 and BCU-22 control units hardware manual \(3AUA0000113605 \[English\]\)](#).

■ ZCU control units

Replacing the memory unit (ZCU-14)

If you replace the control unit, move the memory unit from the old control unit to the new control unit to keep the existing parameter settings.



▲WARNING Obey the safety instructions of the drive. If you ignore them, injury or death, or damage to the equipment can occur. If you are not a qualified electrical professional, do not do electrical installation, commissioning or maintenance work.



▲WARNING Do not remove or install the memory unit when the control unit is energized. There can be a risk of electric shock from relay outputs or adjacent equipment. Also, damage to the control unit or memory unit can occur.

1. Stop the drive and do the steps in [Electrical safety precautions \(page 180\)](#) before you start the work.
2. Make sure that the control unit is not powered.
3. Remove the fastening screw and pull the memory unit out.
4. Install a memory unit in reverse order.

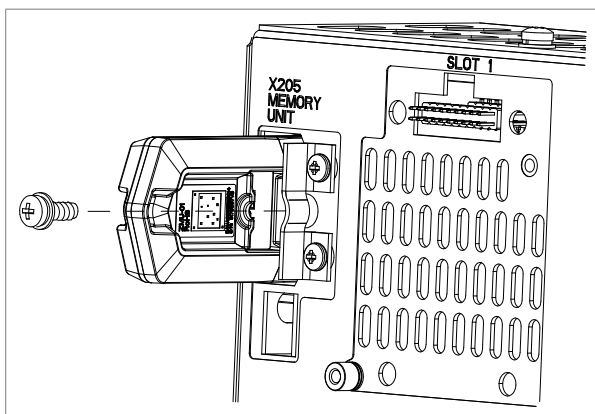

Replacing the control unit battery (ZCU-14)



▲WARNING Obey the safety instructions of the drive. If you ignore them, injury or death, or damage to the equipment can occur. If you are not a qualified electrical professional, do not do electrical installation, commissioning or maintenance work.

1. Stop the drive and do the steps in [Electrical safety precautions \(page 180\)](#) before you start the work.
2. Remove the M4×8 (T20) screws at the ends of the control unit.
3. To see the battery, remove the XD2D terminal block.
4. Carefully lift the edge of the control unit cover on the side with the I/O terminal blocks.
5. Pull the battery out of the battery holder.
6. Put a new CR2032 battery into the battery holder. The procedure for the installation of the control unit cover is the opposite of the removal of the control unit cover. Refer to steps 2-4.

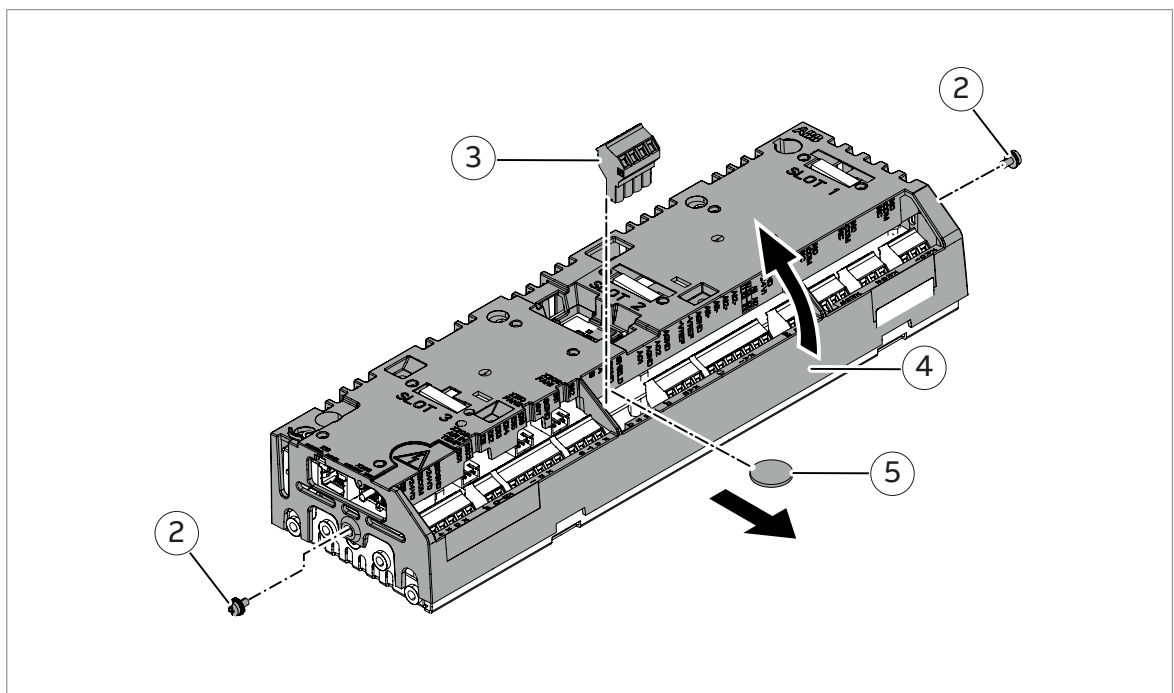

Control panel

Refer to:

- [ACS-AP-I, -S, -W Assistant control panels user's manual \(3AUA0000085685 \[English\]\)](#)
- [ACS-BP-S basic control panels user's manual \(3AXD5000032527 \[English\]\)](#).

LEDs and other status indicators

■ Control panel and panel platform/holder LEDs

The ACS-AP-... control panel has a status LED. The control panel mounting platform or holder has two status LEDs. For status LED indications, refer to the following table.

Location	LED	Indication
Control panel	Continuous green	The unit operates normally.
	Flickering green	Data is transferred between the PC and the unit through the USB connection of the control panel.
	Flashing green	There is an active warning in the unit.
	Continuous red	There is an active fault in the unit.
	Flashing red	There is a fault that requires the stopping and restarting of the drive/converter/inverter.
	Flashing blue (ACS-AP-W only)	The Bluetooth interface is enabled, in discoverable mode, and ready for pairing.
	Flickering blue (ACS-AP-W only)	Data is transferred through the Bluetooth interface of the control panel.
Control panel mounting platform or holder (with the control panel removed)	Red	There is an active fault in the unit.
	Green	Power supply for the control unit is OK.

■ LEDs of the BPA-01 board

LED	Color	Indication
24V OUT FAULT	Continuous red	There is a blown fuse within the BPA-01 board and therefore the X2 connector (24V OUT) is not functioning. Replace the BPA-01 board.
INTERNAL POWER OK	Continuous green	Power supply is OK. BPA-01 board is powered and the fiber optic link is functional.

■ R8i power module LEDs

LED	Color	Indication
FAULT	Continuous red	There is an active fault in the module.
ENABLE / STO	Continuous green	The module is ready for use.
ENABLE / STO	Continuous yellow	XSTO connectors are de-energized.
POWER OK	Continuous green	Supply voltage of the internal circuit boards is sufficient (> 21 V).

Activating the reduced run function of the inverter unit

A “reduced run” function is available for inverter units consisting of parallel-connected inverter modules. The function makes it possible to continue operation with limited current even if one (or more) module is out of service, for example, because of maintenance work. In principle, reduced run is possible with only one module, but the physical requirements of operating the motor still apply; for example, the modules remaining in use must be able to provide the motor with enough magnetizing current.

The wiring accessories needed during the procedure are available from ABB.

■ Starting reduced run operation



▲WARNING Obey the safety instructions of the drive. If you ignore them, injury or death, or damage to the equipment can occur. If you are not a qualified electrical professional, do not do installation, commissioning, or maintenance work.

1. Stop the drive and do the steps in section [Electrical safety precautions \(page 180\)](#) before you start the work.
2. If the inverter control unit is powered from the faulty module, connect the control unit to another 24 V DC power supply. We strongly recommend using an external power supply with inverter units consisting of parallel-connected modules.
3. Remove the module to be serviced from its bay.
4. If the STO (Safe torque off) function is in use, install the STO jumper wire set in place of the missing module (unless the module was the last on the chain).
5. Install an air baffle to the top module guide to block the airflow through the empty module bay.
6. In case the inverter unit has a DC switch with a unit charging circuit, disable the appropriate channel on the charging monitoring unit.
7. Switch on the power to the inverter unit.
8. Enter the number of inverter modules present into parameter 95.13 Reduced run mode.
9. Reset all faults and start the inverter unit. The maximum current is now automatically limited according to the new inverter configuration. A mismatch between the number of detected modules (95.14) and the value set in 95.13 will generate a fault.
10. If the STO function is in use, validate it as described in chapter [The Safe torque off function \(page 389\)](#).

■ Resuming normal operation



▲WARNING Obey the safety instructions of the drive. If you ignore them, injury or death, or damage to the equipment can occur. If you are not a qualified electrical professional, do not do installation, commissioning, or maintenance work.

1. Stop the drive and do the steps in section [Electrical safety precautions \(page 180\)](#) before you start the work.
2. Remove the STO (Safe torque off) jumper wire set (if present).
3. Remove the air baffle from the module bay.
4. Reinstall the module into its bay.
5. Reconnect the STO wiring (if used) to the module.
6. In case the inverter unit has a DC switch with a unit charging circuit, re-enable all channels on the charging monitoring unit.
7. Switch on the power to the inverter unit.
8. Enter “0” into parameter 95.13 Reduced run mode.
9. If the STO function is in use, validate it as described in chapter [The Safe torque off function \(page 389\)](#).

Functional safety components

The mission time of functional safety components is 20 years, which equals the time during which failure rates of electronic components remain constant. This applies to the components of the standard Safe torque off circuit as well as any modules, relays, and other components that are part of functional safety circuits.

The expiry of mission time terminates the certification and SIL/PL classification of the safety function. To certify the components, these options exist:

- Renew the whole drive and all optional functional safety modules and components.
- Renew the components in the safety function circuit. In practice, this is economical only with large drives that have replaceable circuit boards and other components such as relays.

Note that some of the components may have been renewed earlier, which restarts their mission time. The remaining mission time of the whole circuit is, however, determined by its oldest component.

For more information, contact **ABB**.

11

Ordering information

Contents of this chapter

This chapter lists the types and ordering codes of the unit components.

You can find the kit-specific assembly drawings, step-by-step instructions and detailed kit information on the Internet. Go to <https://sites-apps.abb.com/sites/lvacdrivesengineeringsupport/content>. If necessary, contact your local ABB representative.

Note:

- This chapter only lists the installation accessories available from ABB. All other parts must be sourced from a third party (such as Rittal) by the system integrator. For a listing, refer to the kit-specific installation instructions available at <https://sites-apps.abb.com/sites/lvacdrivesengineeringsupport/content>. For access, contact your local ABB representative.
 - Parts that are labeled suitable for generic enclosures are not designed for any specific enclosure system. These parts are intended as a basis for further engineering, and may require additional parts to be fully usable. Installation accessories designed for generic enclosures are in fact designed for an inside width of 50 mm less than the nominal width of the enclosure. For example, a mechanical kit intended for 800 mm wide generic enclosure is designed for an inside width of 750 mm, and will not fit a 800 mm wide Rittal VX25 enclosure.
-

Kit code key

The kit codes shown in this chapter break down as follows.

The format of the kit code is x-w-s-yyy(-VX), for example, L-6-8-401 where:

- x = cooling method
 - A = air-cooled (some of these kits are also used with liquid-cooled drives)
 - L = liquid-cooled
 - w = cabinet width
 - 4 = 400 mm
 - 6 = 600 mm
 - 8 = 800 mm
 - s = module frame size / sizes
 - 1 = R1i
 - 2 = R2i
 - 3 = R3i
 - 4 = R4i
 - 5 = R5i
 - 6 = R6i/D6D
 - 7 = R7i/D7D/D7T
 - 8 = R8i/D8D/D8T
 - X = any, or not defined.
 - yyy = consecutive numbering
 - 001...099 = Kits related to cabinets, for example, adapter plates
 - 001...019 Common AC- and DC-related kits
 - 020...049 Cabinet mechanics kits
 - 050...059 Swing frame kits
 - 100...199 = Kits related to AC connection, for example, busbars
 - 100...129 Kits with connection to AC
 - 130...149 Kits with connection to module
 - 150...199 Other kits related to AC connection
 - 200...299 = Kits related to DC connection, for example, busbars
 - 200...229 Kits with connection to common DC
 - 230...249 Kits with connection to module
 - 250...299 Other kits related to DC connection
-

- 300...399 = Kits related to module installation, for example, mechanical supports
 - 300...330 Module supporting kits, basic mechanical support
 - 350...379 Shroud kits

 - 400...499 = Other kits
 - 400...419 Fan kits
 - 420...439 Air guides
 - 440...459 Cooling circuit kits

 - VX = Kit specifically designed for the Rittal VX25 enclosure system. Many kits without this designation are also used with the VX25 system.
-

Frames R1i...R4i

■ Inverter modules

As standard, frame R1i to R4i inverter modules come with a cover that also acts as a control panel holder. The cover is fitted with a panel interface board (ZDPI-01) which enables the construction of a panel bus. The panel bus makes it possible to control several inverter units from a single control panel.

The modules can be ordered without the cover by specifying option code +OJ414. (If desired, the panel bus can be constructed using FDPI-02 modules which are available separately.)

Ordering code	Contents
<p>[Module type] For example, ACS880-104-008A0-3</p>	<ul style="list-style-type: none"> • Inverter module (1) with ZCU control unit (1a) • ZMU memory unit (2) with ACS880 primary control program. For availability of other control programs, contact your local ABB representative. • Module cover with control panel holder (3) • ZDPI-01 panel interface board (4) • Cable from ZDPI-01 to control unit (5) • Control cable grounding/strain relief plate (6) with adapter (6a) • Two power cable grounding/strain relief plates (7a, 7b) • Module air temperature sensor (8) with mounting plate (8a)
<p>[Module type]+0J414 For example, ACS880-104-008A0-3+0J414</p>	<p>Same content as for [Module type] but these parts are left out:</p> <ul style="list-style-type: none"> • Module cover with control panel holder (3) • ZDPI-01 panel interface board (4) • Cable from ZDPI-01 to control unit (5)
<p>[Module type]+N8010 For example, ACS880-104-008A0-3+N8010</p>	<p>Same content as for [Module type] but:</p> <ul style="list-style-type: none"> • ACS880 primary control program with application programmability using function blocks based on the IEC 61131-3 standard. For more information, see Programming manual: Drive application programming (IEC 61131-3) (3AUA0000127808 [English]).
<p>For module types, refer to Ratings.</p>	

Control panel

The control panel is not included with the module but must be ordered separately. One control panel is required for the commissioning of an ACS880 drive system, even if the Drive Composer PC tool is used.

The control panel can be flush mounted on the cabinet door with the help of a door mounting kit. For more information on the control panel, refer to [ACS-AP-I, -S, -W and ACH-AP-H, -W Assistant control panels user's manual \(3AUA0000085685 \[English\]\)](#).

Type	Description	Ordering code	Illustration
ACS-AP-W	Control panel with Bluetooth	3AXD50000025965	
DPMP-01	Door mounting kit (IP55)	3AUA0000108878	
DPMP-02	Door mounting kit (IP65)	3AXD50000009374	

For more information on the door mounting kits, such as the contents of the kit, refer to the installation manuals:

- [DPMP-01 mounting platform for control panels installation guide \(3AUA0000100140 \[English\]\)](#)
- [DPMP-02/03 mounting platform for control panels installations guide \(3AUA0000136205 \[English\]\)](#).

■ DC-side components

Frame R1i...R4i inverter modules are connected to the DC bus through individual fuses. The fuses are installed on fuse bases that can be opened under no load. Microswitches are used for monitoring the open/closed state of the fuse bases. The fuse bases specified for frame sizes R3i and R4i include the microswitches as standard; the microswitches must be ordered separately for R1i and R2i fuse bases.

A main DC switch/disconnector and DC fuses for all the modules in the same enclosure can optionally be added. The main DC fuses are typically used to protect against short-circuits in the DC path to the module fuses when a high-power supply unit is used.

DC bus installation parts (for Rittal VX25 enclosures)

The brackets in this kit act as a mounting base for the busbar supports of the Rittal Flat-PLS DC link and ensure its correct placement and alignment inside the cabinet line-up.

The designs shown in this manual for Rittal VX25 enclosures use the Rittal Flat-PLS busbar system. Make sure that the current in the drive system does not exceed the current-carrying capacity of the busbars.

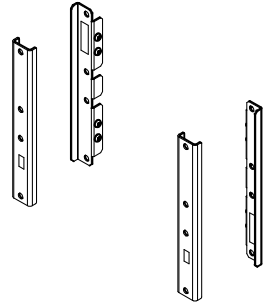
Used with ...	Qty	Ordering code	Kit code	Illustration
VX25 enclosure	1 kit per cubicle	3AXD50000333387	A-468-X-001-VX	 <p>Instruction code: 3AXD50000333639</p>

Module-specific DC fuses (IEC, UL)

Module type ACS880-104-...		Fuse		Qty	Ordering code
		Type	Data		
004A8-3 006A0-3	003A6-5 004A8-5	FWP-10A14Fa*	10 A, 660 V	2	3AUA0000089115
008A0-3	006A0-5	FWP-15A14Fa*	15 A, 660 V	2	3AUA0000089116
0011A-3	008A0-5	FWP-20A14Fa*	20 A, 660 V	2	3AUA0000089117
0014A-3	0011A-5	FWP-25A14Fa*	25 A, 660 V	2	3AUA0000089118
0018A-3	0014A-5 0018A-5	FWP-32A14Fa*	32 A, 660 V	2	3AUA0000089119
0025A-3	0025A-5	6,921 CP URQ 27x60/50**	50 A, 690 V	2	3AXD50000000189
0035A-3	0030A-5	6,921 CP URQ 27x60/63**	63 A, 690 V	2	3AXD50000000211
0044A-3	0035A-5	6,921 CP URQ 27x60/80**	80 A, 690 V	2	3AXD50000000213
0050A-3	0050A-5	6,921 CP URQ 27x60/100**	100 A, 690 V	2	3AXD50000000215
0061A-3	0061A-5	6,921 CP URQ 27x60/125**	125 A, 690 V	2	3AXD50000000217
0078A-3	0078A-5	6,921 CP URQ 27x60/160**	160 A, 690 V	2	3AXD50000000219
0094A-3 0100A-3	0094A-5	6,921 CP URQ 27x60/200**	200 A, 690 V	2	3AXD50000000221
*Size: 14 × 51 mm					
**Size: 27 × 60 mm					

Module-specific DC fuse bases (IEC, UL)

Module type ACS880-104-...		Fuse base		Qty	Ordering code
		Type	Data		
004A8-3 ...	003A6-5 ...	US141 (Z331153F)	14 × 51 mm 50 A, 690 V	2	3AUA0000089224 (fuse base)
0018A-3	0018A-5			2	3AUA0000089228 (microswitch)
0025A-3 ...	0025A-5 ...	US271MI (R227600C)	27 × 60 mm 140 A, 800 V	2	3AUA0000089227 (microswitch included)
0100A-3	0094A-5				

Main DC switch/disconnector kits

IEC				
Enclosure width	DC switch/disconnector		Qty	Ordering code
	Type	Data		
400 mm	OT400E11	2-pole, 400 A	1	3AXD50000000891
600 mm	OT630E11	2-pole, 630 A	1	3AXD50000000892
800 mm	OT400E22	4-pole, 400 A	1	3AXD50000000893

UL				
Enclosure width	DC switch/disconnector		Qty	Ordering code
	Type	Data		
400 mm	OT400U11	2-pole, 400 A	1	3AXD500000002764
600 mm	OT600U11	2-pole, 600 A	1	3AXD500000002765
800 mm	OT400U22	4-pole, 400 A	1	3AXD500000002767

Kit contents:

- DC switch/disconnector
- Shaft (12 × 325 mm)
- OHB__J12 handle with off/on indication
- OA1G10 normally-open auxiliary contact block.

Main DC fuses (IEC, UL)

Enclosure width	DC fuse		Qty	Ordering code
	Type	Data		
400 mm	170M4413	450 A, 690 V	2	68731623
600 mm	170M4418	800 A, 690 V	2	3AXD50000000250
800 mm	170M4413	450 A, 690 V	4	68731623

Busbars between main DC switch/disconnector and fuses

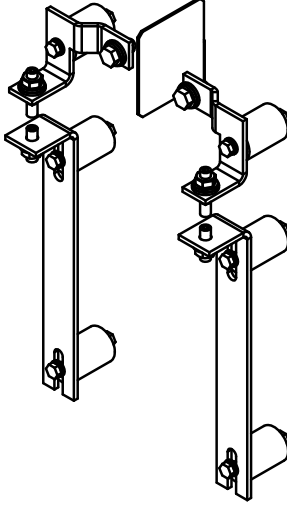
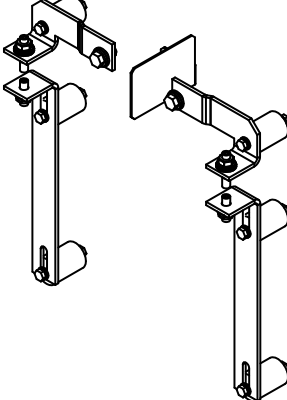
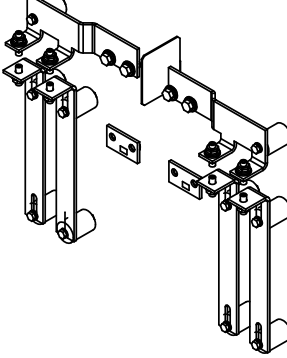
Used with...	Qty	Ordering code	Kit code	Illustration
400 mm IEC	1	3AXD50000474493	A-4-1234-272-VX	 <p data-bbox="1053 896 1244 952">Instruction code: 3AXD50000453108</p>
600 mm IEC	1	3AXD50000475964	A-6-1234-271-VX	 <p data-bbox="1053 1422 1244 1478">Instruction code: 3AXD50000460779</p>
800 mm IEC	1	3AXD50000475933	A-8-1234-273-VX	 <p data-bbox="1053 1915 1244 1971">Instruction code: 3AXD50000474516</p>

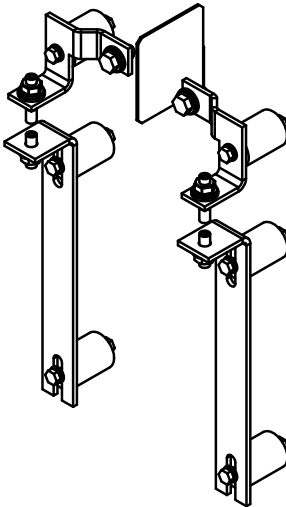
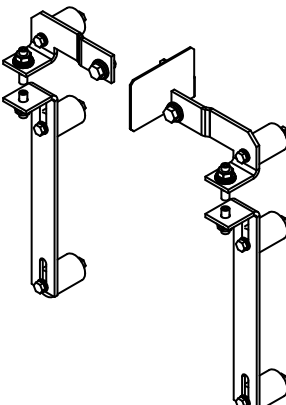
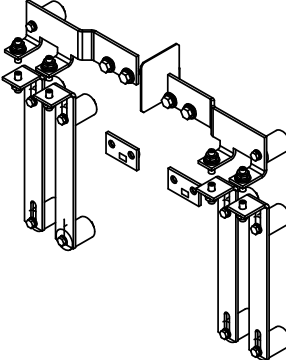
Used with...	Qty	Ordering code	Kit code	Illustration
400 mm UL	1	3AXD50000003918	A-4-1234-274	 <p data-bbox="1204 828 1396 884">Instruction code: 3AXD50000003895</p>
600 mm UL	1	3AXD50000475964	A-6-1234-271-VX	 <p data-bbox="1204 1355 1396 1411">Instruction code: 3AXD50000460779</p>
800 mm UL	1	3AXD50000003919	A-8-1234-275	 <p data-bbox="1204 1848 1396 1904">Instruction code: 3AXD50000003875</p>

■ AC-side components

Output (du/dt) filters

For information on the usage of output (du/dt) filters, see [ACS880 multidrives cabinets and modules electrical planning instructions \(3AUA0000102324 \[English\]\)](#).

Module type ACS880-104-...		Fuse base		Qty	Ordering code
		Type	Data		
004A8-3	003A6-5	NOCH0016-60	I_{RMS} : 15 A L : 150 μ H Power loss: 110 W Cable size: 0.2 ... 10 mm ² Connection: M5	1	58982784
006A0-3	004A8-5				
008A0-3	006A0-5				
0011A-3	008A0-5				
0014A-3	0011A-5				
0018A-3	0014A-5 0018A-5				
0025A-3	0025A-5	NOCH0030-60	I_{RMS} : 28 A L : 140 μ H Power loss: 167 W Cable size: 0.5 ... 16 mm ² Connection: M5	1	58982792
0035A-3	0030A-5				
	0035A-5				
0044A-3	0050A-5	NOCH0070-60	I_{RMS} : 65 A L : 115 μ H Power loss: 210 W Cable size: 10...35 mm ² Connection: M6	1	58982806
0050A-3	0061A-5				
0061A-3	0078A-5				
0078A-3	0094A-5				
0094A-3					
0100A-3					

■ Mechanical installation accessories

These kits include parts that are required for installing the inverter module in the enclosure.

Mounting plate shroud kits

The plates are installed in front of the main DC switch and fuses. The module-specific fuse disconnectors are installed onto this plate.

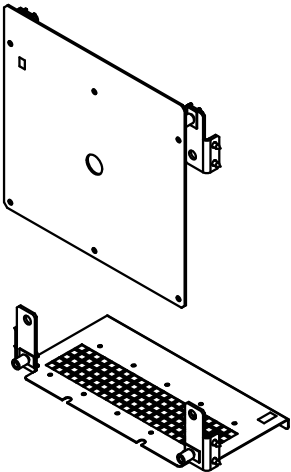
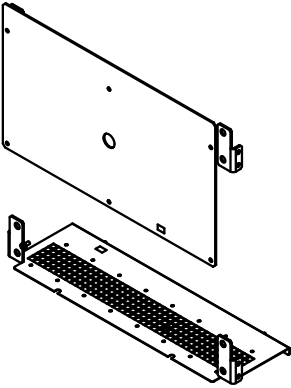
Enclosure width	Qty	Ordering code	Kit code	Illustration
400 mm	1	3AXD50000456772	A-4-1234-403-VX	 <p>Instruction code: 3AXD50000450060</p>
600 mm	1	3AXD50000456819	A-6-1234-402-VX	 <p>Instruction code: 3AXD50000461691</p>

288 Ordering information

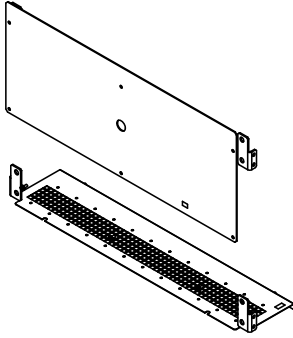
Enclosure width	Qty	Ordering code	Kit code	Illustration
800 mm	1	3AXD50000475926	A-8-1234-404-VX	 <p>Instruction code: 3AXD50000474882</p>

Air guide kits

The air guide directs the hot air exiting the inverter module into the hot area at the rear of the cubicle.

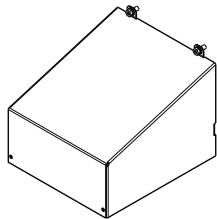
Frame size	Qty	Ordering code	Kit code	Illustration
R1i	1	3AUA0000114398	A-468-1-422	 <p>Instruction code: 3AUA0000114397</p>
R2i	1	3AUA0000114330	A-468-2-423	
R3i	1	3AUA0000114404	A-468-3-424	
R4i	1	3AUA0000114405	A-468-4-425	

Frame R5i

■ Inverter module

As standard, frame R5i inverter modules come with a two-part front cover, the top part of which also acts as a control panel holder. The holder is fitted with a panel interface board (ZDPI-01) which enables the construction of a panel bus. The panel bus makes it possible to control several inverter units from a single control panel.

The modules can be ordered without the front covers by specifying option code +0J414. (If desired, the panel bus can be constructed using FDPI-02 modules which are available separately.)

290 Ordering information

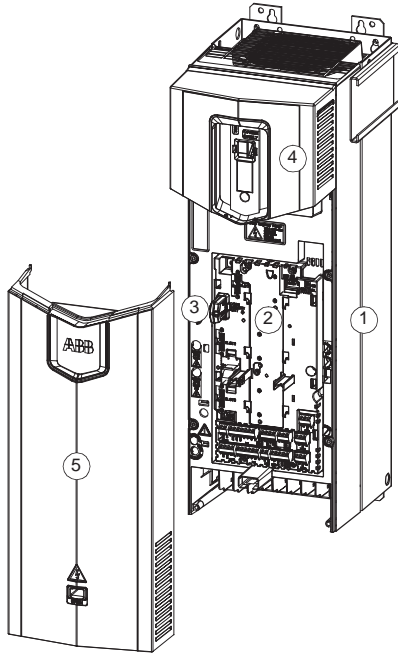
Ordering code	Contents
<p>[Module type] For example, ACS880-104-007A3-7</p>	<ul style="list-style-type: none"> • Inverter module (1) with ZCU-12 control unit (2) • ZMU memory unit (3) with ACS880 primary control program. For availability of other control programs, contact your local ABB representative. • Module front cover, top (4) including <ul style="list-style-type: none"> • Control panel holder • ZDPI-01 panel interface board • Cable from ZDPI-01 to control unit • Module front cover, bottom (5) • Cabinet cooling fan wire (connector with a stretch of wire). <p>Note: Inverter module does not have the internal charging circuit (option +F272).</p>
<p>[Module type]+C132 For example, ACS880-104-007A3-7+C132</p>	<p>Same content as for [Module type] but:</p> <ul style="list-style-type: none"> • Marine type approval. For more information, refer to ACS880 +C132 marine type-approved drive modules and module packages supplement (3AXD50000037752 [English]).
<p>[Module type]+OJ414 For example, ACS880-104-007A3-7+OJ414</p>	<p>Same content as for [Module type] but:</p> <ul style="list-style-type: none"> • Inverter module (1) without front covers (4, 5).
<p>[Module type]+N8010 For example, ACS880-104-007A3-7+N8010</p>	<p>Same content as for [Module type] but:</p> <ul style="list-style-type: none"> • ACS880 primary control program with application programmability using function blocks based on the IEC 61131-3 standard. For more information, refer to Programming manual: Drive application programming (IEC 61131-3) (3AUA0000127808 [English]).
	
<p>For module types, refer to Ratings.</p>	

■ Control panel

The control panel is not included with the module but must be ordered separately. One control panel is required for the commissioning of an ACS880 drive system, even if the Drive Composer PC tool is used.

The control panel can be flush mounted on the cabinet door with the help of a door mounting kit. For more information on the control panel, refer to [ACS-AP-I, -S, -W and ACH-AP-H, -W Assistant control panels user's manual \(3AUA0000085685 \[English\]\)](#).

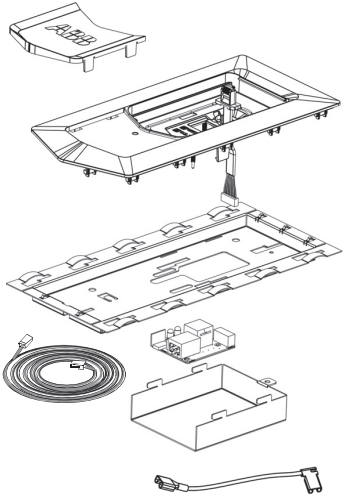
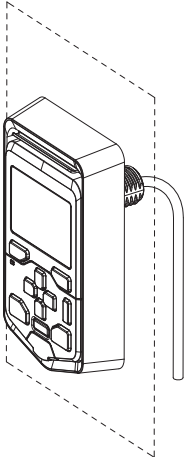
Type	Description	Ordering code	Illustration
ACS-AP-W	Control panel with Bluetooth	3AXD50000025965	
DPMP-01	Door mounting kit (IP55)	3AUA0000108878	
DPMP-02	Door mounting kit (IP65)	3AXD50000009374	

For more information on the door mounting kits, such as the contents of the kit, refer to the installation manuals:

- [DPMP-01 mounting platform for control panels installation guide \(3AUA0000100140 \[English\]\)](#)
- [DPMP-02/03 mounting platform for control panels installations guide \(3AUA0000136205 \[English\]\)](#).

■ DC-side components

Frame R5i inverter modules are connected to the DC bus through individual fuses. The fuses are installed on fuse bases that can be opened under no load. Microswitches are used for monitoring the open/closed state of the fuse bases. The fuse bases listed below include the microswitches as standard.

A main DC switch/disconnector and DC fuses for all the modules in the same enclosure can optionally be added. The main DC fuses are typically used to protect against short-circuits in the DC path to the module fuses when a high-power supply unit is used.

DC bus installation parts (for Rittal VX25 enclosures)

The brackets in this kit act as a mounting base for the busbar supports of the Rittal Flat-PLS DC link and ensure its correct placement and alignment inside the cabinet line-up.

The designs shown in this manual for Rittal VX25 enclosures use the Rittal Flat-PLS busbar system. Make sure that the current in the drive system does not exceed the current-carrying capacity of the busbars.

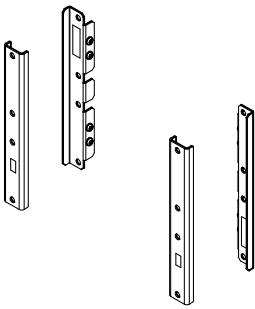
Used with ...	Qty	Ordering code	Kit code	Illustration
VX25 enclosure	1 kit per cubicle	3AXD50000333387	A-468-X-001-VX	 <p>Instruction code: 3AXD50000333639</p>

Module-specific DC fuses (IEC, UL)

Module type ACS880-104-...	Fuse		Qty	Ordering code
	Type	Data		
007A3-7 009A8-7 014A2-7 0018A-7	1021 CP URB 27x60/40*	40 A, 1000 V	2	3AUA0000089197
0022A-7 0027A-7 0035A-7 0042A-7 0052A-7	1021 CP URB 27x60/100*	100 A, 1000 V	2	3AUA0000089211
*Size: 27 × 60 mm				

Module-specific DC fuse bases (IEC, UL)

Module type ACS880-104-...	Fuse base		Qty	Ordering code
	Type	Data		
007A3-7 009A8-7 014A2-7 0018A-7 0022A-7 0027A-7 0035A-7 0042A-7 0052A-7	PS272PREMCPS (N220076)	27 × 60 mm 250 A, 1250 V DC	1	3AXD50000012958 (microswitch included)

Main DC switch/disconnector kits

IEC					
Enclosure width	Qty of modules	DC switch/disconnector		Qty	Ordering code
		Type	Data		
400 mm	2 × R5i	OT200E11	2-pole, 200 A	1	3AXD50000015608
600 mm	4 × R5i	OT400E11	2-pole, 400 A	1	3AXD50000001306

UL					
Enclosure width	Qty of modules	DC switch/disconnector		Qty	Ordering code
		Type	Data		
400 mm	2 × R5i	OT200U11	2-pole, 200 A	1	3AXD50000024411
600 mm	4 × R5i	OT400U11	2-pole, 400 A	1	3AXD50000002764

294 Ordering information

Kit contents:

- DC switch/disconnector
- Shaft (6 × 430 mm for 400 mm enclosure width, 12 × 325 mm for 600 mm enclosure width)
- Handle with off/on indication (OHB65J6 for 400 mm enclosure width, OHB125J12 for 600 mm enclosure width)
- OA1G10 normally-open auxiliary contact block.

Main DC fuses (IEC, UL)

Enclosure width	Qty of modules	Fuse			Qty	Ordering code
		Type	Data	Size		
400 mm	2 × R5i	170M4389	200 A, 1250 V	1	2	3AXD50000010195
600 mm	4 × R5i	170M4393	400 A, 1250 V	1	2	3AUA0000076327

DC busbars (IEC, UL)

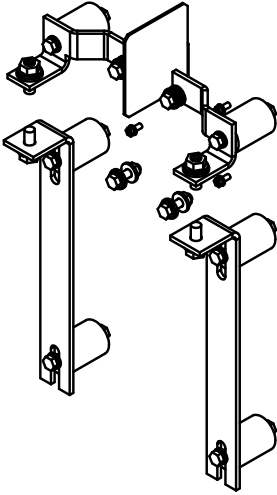
Enclosure width	Qty	Ordering code	Kit code	Illustration
400 mm	1	3AXD50000456802	A-4-5-276-VX	 <p>Instruction code: 3AXD50000458110</p>

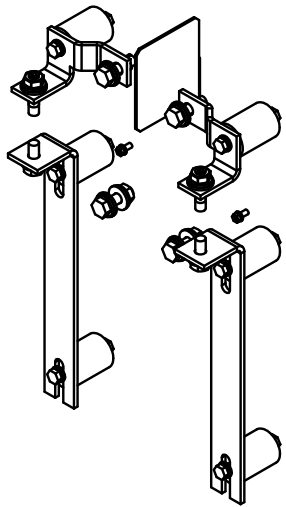
Enclosure width	Qty	Ordering code	Kit code	Illustration
600 mm	1	3AXD50000456826	A-6-5-277-VX	 <p>Instruction code: 3AXD50000461332</p>

■ AC-side components

Output (du/dt) filters

For information on the usage of output (du/dt) filters, see [ACS880 multidrives cabinets and modules electrical planning instructions \(3AUA0000102324 \[English\]\)](#).

Module type ACS880-104-...	Filter		Qty	Ordering code
	Type	Data		
007A3-7 009A8-7 014A2-7	NOCH0016-60	I_{RMS} : 15 A L : 150 μ H Power loss: 110vW Cable size: 0.2 ... 10 mm ² Connection: M5	1	58982784
0018A-7 0022A-7 0027A-7	NOCH0030-60	I_{RMS} : 28 A L : 140 μ H Power loss: 167 W Cable size: 0.5 ... 16 mm ² Connection: M5	1	58982792
0035A-7 0042A-7 0052A-7	NOCH0070-60	I_{RMS} : 65 A L : 115 μ H Power loss: 210 W Cable size: 10...35 mm ² Connection: M6	1	58982806

■ Mechanical installation accessories

These kits include parts that are required for installing the inverter module in the enclosure.

Mounting plate shroud kits

The shrouds are to be attached to the Rittal partial mounting plate mounted in front of the DC switch. The module-specific fuse disconnectors are to be installed onto the vertical plate.

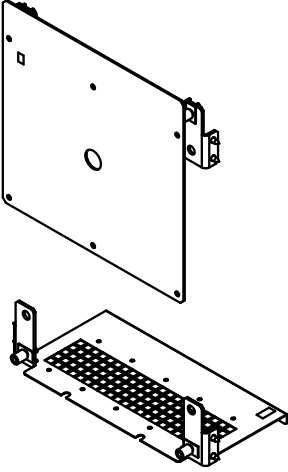
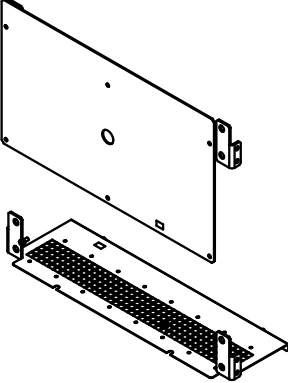
Enclosure width	Qty	Ordering code	Kit code	Illustration
400 mm	1	3AXD50000456772	A-4-1234-403-VX	 <p data-bbox="1050 981 1252 1032">Instruction code: 3AXD50000450060</p>
600 mm	1	3AXD50000456819	A-6-1234-402-VX	 <p data-bbox="1050 1485 1252 1536">Instruction code: 3AXD50000461691</p>

Fuse base shroud kit

IP20 protection of the DC fuse bases requires shrouding both above and below. One shroud kit contains the shrouds for each dual fuse base.

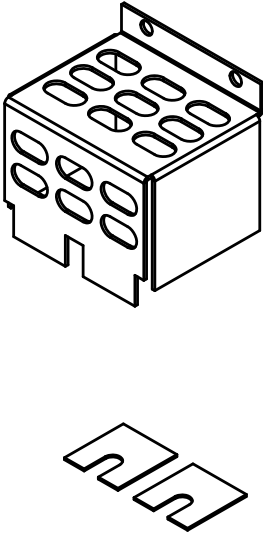
Used with...	Qty	Ordering code	Kit code	Illustration
<p>R5i modules installed in 400 or 600 mm wide cubicles</p>	<p>1 per module</p>	<p>3AXD50000456796</p>	<p>A-X-5-356-VX</p>	 <p>Instruction code: 3AXD50000458424</p>

Frames R6i and R7i

■ Inverter modules

Deliveries of frame R6i and R7i inverter modules include the following items:

Ordering code	Contents
[Module type]+V992 For example, ACS880-104-0210A-3+V992	<ul style="list-style-type: none"> Inverter module with ZCU-12 control unit ZMU memory unit with ACS880 primary control program. For availability of other control programs, contact your local ABB representative. Inverter module hardware version +V992 <p>Note: Inverter module does not have the internal charging circuit (option +F272).</p>
[Module type]+C132 For example, ACS880-104-0210A-3+V992+C132	<p>Same content as for [Module type]+V992 but:</p> <ul style="list-style-type: none"> Marine type approval. For more information, refer to ACS880 +C132 marine type-approved drive modules and module packages supplement (3AXD50000037752 [English]).
[Module type]+V992+F272 For example, ACS880-104-0210A-3+V992+F272	<p>Same content as for [Module type]+V992 but:</p> <ul style="list-style-type: none"> Inverter module with internal charging circuit (note that R7i still requires additional external components for the charging)
[Module type] +V992+C249 For example, ACS880-104-0210A-3+V992+C249	<p>Same content as for [Module type]+V992 but:</p> <ul style="list-style-type: none"> BPA power unit adapter mounted onto the module for connection of the control unit. The control unit is to be ordered separately and mounted outside the module.
[Module type] +N8010 For example, ACS880-104-0210A-3+V992+N8010	<p>Same content as for [Module type]+V992 but:</p> <ul style="list-style-type: none"> ACS880 primary control program with application programmability using function blocks based on the IEC 61131-3 standard. For more information, refer to Programming manual: Drive application programming (IEC 61131-3) (3AUA0000127808 [English]).
For module types, refer to Ratings.	

Note: The following components are also required to construct a working unit and must be ordered separately:

- An ACS-AP-x control panel is required for the commissioning of an ACS880 drive system, even if the Drive composer PC tool is used.
- Common mode filters.
- Inverter control unit if you order option +C249. For more information, refer to [Control electronics](#).

The other parts listed in this chapter for these frame sizes

- may be required by the application (such as a DC switch/disconnector), or
- make the installation or use of the module easier.

■ Control panel

The control panel is not included with the module but must be ordered separately. One control panel is required for the commissioning of an ACS880 drive system, even if the Drive Composer PC tool is used.

The control panel can be flush mounted on the cabinet door with the help of a door mounting kit. For more information on the control panel, refer to [ACS-AP-I, -S, -W and ACH-AP-H, -W Assistant control panels user's manual \(3AUA0000085685 \[English\]\)](#).

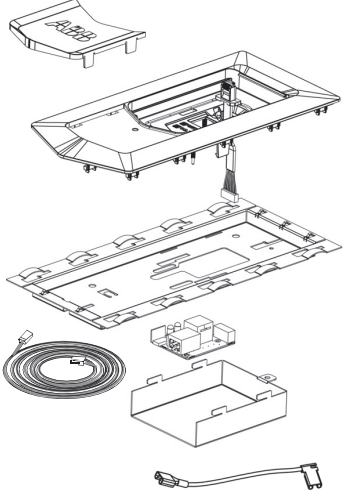
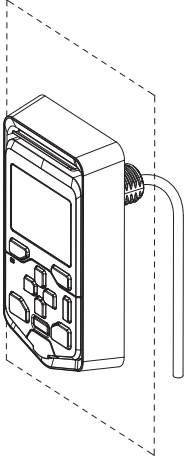
Type	Description	Ordering code	Illustration
ACS-AP-W	Control panel with Bluetooth	3AXD50000025965	
DPMP-01	Door mounting kit (IP55)	3AUA0000108878	
DPMP-02	Door mounting kit (IP65)	3AXD50000009374	

For more information on the door mounting kits, such as the contents of the kit, refer to the installation manuals:

- [DPMP-01 mounting platform for control panels installation guide \(3AUA0000100140 \[English\]\)](#)
- [DPMP-02/03 mounting platform for control panels installations guide \(3AUA0000136205 \[English\]\)](#).

■ Control electronics

BCU-02 or UCU-22 control unit can control DC voltage, which is useful in marine applications, for example. With option +C249, you can order an external BCU-02 or UCU-22 control unit for frames R6i and R7i. Option +C249 includes a BPA-01 board for fiber-optic cable connection that is installed onto the module. BCU-02 or UCU-22 control unit can be installed outside the module. With option +C249, you can install the module into a cabinet that is 500 mm in depth. Without option +C249, you can install the module into a cabinet that is 600 mm in depth.

Control unit (UCU)

Frame size	Type	Ordering code (for options, see below)
R6i, R7i	UCU-22	ACS880UCU-104-22-0

Ordering code format	Option codes
[Control unit type] + code [+code]... For example, ACS880UCU-104-22-0+N8010	+N8010: Application programming

The UCU-22 control unit kit contains:

- UCU-22 control unit with USCA-02 adapters.
- UMU-01 memory unit with the control program.

The following option module is to be installed on the control unit and must be ordered separately if communication between supply and drive units is needed:

- RDCO-04C DDCS communication option module (ordering code: 3AXD50000868056).

Control unit (BCU)

Frame size	Control unit type	Ordering code
R6i, R7i	BCU-02	3AXD50000003417

Fiber-optic cables

Each inverter module is connected to the inverter control unit with a pair of fiber-optic cables. If you order frame R6i or R7i module with option +C249, you must also order fiber optic cables.

Each of the kits in the table below contain a pair of plastic fiber-optic cables that are needed in communication between the control unit and the power (inverter/supply/brake/converter) module.

Length	Kit type designation	Ordering code
2 m (6.6 ft)	NLWC-02	58988821
3 m (9.8 ft)	NLWC-03	58948233
5 m (16.4 ft)	NLWC-05	58948250
7 m (23 ft)	NLWC-07	58948268
10 m (32.8 ft)	NLWC-10	58948276

■ DC-side components

Frame R6i and R7i inverter modules are connected to the DC bus through fuses. The design presented in this manual has flush-end fuse blocks bolted to the DC busbars.

A DC switch/disconnector can be installed if quick isolation of the module from the DC bus is required. One of the auxiliary contacts of the switch is used for monitoring the open/closed state of the switch.

A capacitor charging circuit must be fitted if

- the inverter module is connected to the DC bus through a DC switch/disconnector, or
- the inverter unit is directly connected to the DC bus and the supply unit of the system does not have a charging capability.

If a charging circuit is required, the inverter module is to be ordered using option code +F272. With frame R6i, all charging components are built into the module. R7i modules with option code +F272 require an external charging contactor and resistors, which are included in the DC connection kit for frame R7i.

The common mode filters are mounted onto the busbars that connect to the DC input of the inverter module.

DC bus installation parts (for Rittal VX25 enclosures)

The brackets in this kit act as a mounting base for the busbar supports of the Rittal Flat-PLS DC link and ensure its correct placement and alignment inside the cabinet line-up.

The designs shown in this manual for Rittal VX25 enclosures use the Rittal Flat-PLS busbar system. Make sure that the current in the drive system does not exceed the current-carrying capacity of the busbars.

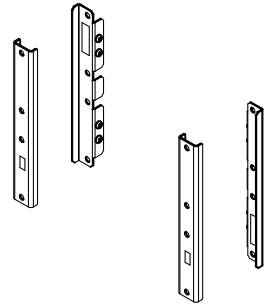
Used with ...	Qty	Ordering code	Kit code	Illustration
VX25 enclosure	1 kit per cubicle	3AXD50000333387	A-468-X-001-VX	 <p>Instruction code: 3AXD50000333639</p>

302 Ordering information

DC fuses

Module type ACS880-104-...	Fuse			Qty	Ordering code
	Type	Data	Size		
0140A-3	170M4410	315 A, 690 V	1	2	3AXD50000000234
0170A-3	170M4412	400 A, 690 V	1	2	3AXD50000000238
0210A-3	170M4413	450 A, 690 V	1	2	68731623
0250A-3	170M4414	500 A, 690 V	1	2	3AXD50000000242
0300A-3	170M4416	630 A, 690 V	1	2	3AXD50000000246
0350A-3	170M4417	700 A, 690 V	1	2	64607383
0110A-5	170M4409	250 A, 690 V	1	2	3AUA0000066038
0140A-5	170M4410	315 A, 690 V	1	2	3AXD50000000234
0170A-5	170M4412	400 A, 690 V	1	2	3AXD50000000238
0200A-5	170M4412	400 A, 690 V	1	2	3AXD50000000238
0240A-5	170M4414	500 A, 690 V	1	2	3AXD50000000242
0300A-5	170M4416	630 A, 690 V	1	2	3AXD50000000246
0340A-5	170M4417	700 A, 690 V	1	2	64607383
0062A-7	170M3392	125 A, 1250 V	1*	2	3AXD50000010198
0082A-7	170M4388	160 A, 1250 V	1	2	3AUA0000114934
0100A-7	170M4389	200 A, 1250 V	1	2	3AXD50000010195
0130A-7	170M4390	250 A, 1250 V	1	2	3AUA0000114933
0140A-7	170M4391	315 A, 1250 V	1	2	3AXD50000010196
0190A-7	170M4392	350 A, 1250 V	1	2	3AXD50000010197
0220A-7	170M4393	400 A, 1250 V	1	2	3AUA0000076327
0270A-7	170M4395	500 A, 1100 V	1	2	3AUA0000114932

Module type ACS880-104- ...+V992	Fuse (IEC)			Qty	Ordering code
	Type	Data	Size		
0140A-3	170M4410	315 A, 690 V	1	2	3AXD50000000234
0170A-3	170M4412	400 A, 690 V	1	2	3AXD50000000238
0210A-3	170M4413	450 A, 690 V	1	2	68731623
0250A-3	170M4414	500 A, 690 V	1	2	3AXD50000000242
0300A-3	170M4416	630 A, 690 V	1	2	3AXD50000000246
0350A-3	170M4417	700 A, 690 V	1	2	64607383
0110A-5	170M4409	250 A, 690 V	1	2	3AUA0000066038
0140A-5	170M4410	315 A, 690 V	1	2	3AXD50000000234
0170A-5	170M4412	400 A, 690 V	1	2	3AXD50000000238
0200A-5	170M4412	400 A, 690 V	1	2	3AXD50000000238
0240A-5	170M4414	500 A, 690 V	1	2	3AXD50000000242
0300A-5	170M4416	630 A, 690 V	1	2	3AXD50000000246
0340A-5	170M4417	700 A, 690 V	1	2	64607383
0062A-7	170M3392	125 A, 1250 V	1*	2	3AXD50000010198
0082A-7	170M4388	160 A, 1250 V	1	2	3AUA0000114934
0100A-7	170M4389	200 A, 1250 V	1	2	3AXD50000010195
0130A-7	170M4390	250 A, 1250 V	1	2	3AUA0000114933
0140A-7	170M4391	315 A, 1250 V	1	2	3AXD50000010196
0190A-7	170M4392	350 A, 1250 V	1	2	3AXD50000010197
0220A-7	170M4393	400 A, 1250 V	1	2	3AUA0000076327
0270A-7	170M4395	500 A, 1100 V	1	2	3AUA0000114932

304 Ordering information

Module type ACS880-104-...+V992	Fuse (UL)			Qty	Ordering code
	Type	Data	Size		
0140A-3	170M4410	315 A, 700 V	1	2	3AXD50000000234
0170A-3	170M4412	400 A, 700 V	1	2	3AXD50000000238
0210A-3	170M4413	450 A, 700 V	1	2	3AXD50001114732
0250A-3	170M4414	500 A, 700 V	1	2	3AXD50000000242
0300A-3	170M4416	630 A, 700 V	1	2	3AXD50000000246
0350A-3	170M4417	700 A, 700 V	1	2	3AXD50001114749
0110A-5	170M4389	200 A, 1300 V	1	2	3AXD50000010195
0140A-5	170M4390	250 A, 1300 V	1	2	3AUA0000114933
0170A-5	170M4391	315 A, 1300 V	1	2	3AXD50000010196
0200A-5	170M4393	400 A, 1300 V	1	2	3AUA0000076327
0240A-5	170M6541	450 A, 1300 V	3	2	63919021
0300A-5	170M6543	550 A, 1300 V	3	2	3AXD50000698752
0340A-5	170M6545	700 A, 1300 V	3	2	63919110
0062A-7	170M3392	125 A, 1300 V	1*	2	3AXD50000010198
0082A-7	170M4388	160 A, 1300 V	1	2	3AUA0000114934
0100A-7	170M4389	200 A, 1300 V	1	2	3AXD50000010195
0130A-7	170M4390	250 A, 1300 V	1	2	3AUA0000114933
0140A-7	170M4391	315 A, 1300 V	1	2	3AXD50000010196
0190A-7	170M4392	350 A, 1300 V	1	2	3AXD50000010197
0220A-7	170M4393	400 A, 1300 V	1	2	3AUA0000076327
0270A-7	170M6543	550 A, 1300 V	3	2	3AXD50000698752

DC switch/disconnector kits

IEC						
Module type ACS880-104-...			DC switch/disconnector		Qty	Ordering code
			Type	Data		
0140A-3	0110A-5	0062A-7	OT400E11	2-pole, 400 A	1	3AXD50000001306
0170A-3	0140A-5	0082A-7				
0210A-3	0170A-5	0100A-7				
0250A-3	0200A-5	0130A-7				
	0240A-5	0140A-7				
		0190A-7				
		0220A-7				
		0270A-7				
0300A-3	0300A-5		OT630E11	2-pole, 630 A	1	3AXD50000001307
0350A-3	0340A-5					

UL						
Module type ACS880-104-...			DC switch/disconnector		Qty	Ordering code
			Type	Data		
0140A-3	0110A-5	0062A-7	OT400U11	2-pole, 400 A	1	3AXD50000002791
0170A-3	0140A-5	0082A-7				
0210A-3	0170A-5	0100A-7				
0250A-3	0200A-5	0130A-7				
		0140A-7				
		0190A-7				
		0220A-7				
	0270A-7					
0300A-3	0340A-5		OT600U11	2-pole, 600 A	1	3AXD50000002792
0350A-3	0300A-5					

Kit contents:

- DC switch/disconnector
- Shaft (12 × 395 mm)
- OHB__J12 handle with off/on indication
- OA1G10 normally-open auxiliary contact block.

Charging kit (R7i only)

Module type ACS880-104-...			Qty	Ordering code
0300A-3	0300A-5		1	3AXD50000001328
0350A-3	0340A-5			
		0220A-7 0270A-7	1	3AXD50000018982
0300A-3 +V992	0300A-5 +V992	0220A-7 +V992		
0350A-3 +V992	0340A-5 +V992	0270A-7 +V992		

Kit contents:

- AF190-30-00-13 charging contactor
- 2 pcs CEL19-10 auxiliary contacts
- 2 pcs 36 ohm charging resistor
- Wire set.

DC connection kit for Rittal VX25 enclosures

This kit contains the busbars from the DC bus towards the module as well as an air guide, mounting plate, insulators and screws. The assembly incorporates the electrical components (such as DC fuses, DC switch/disconnector, and charging components) whenever required; note that the electrical parts are to be ordered separately as detailed above.

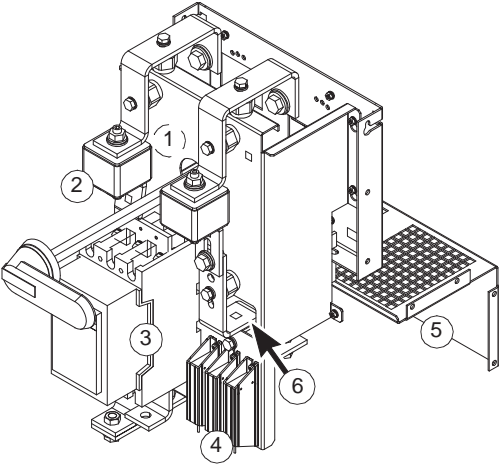
	Item	Explanation
	1	DC switch/disconnector (obscured by mounting plate)
	2	DC fuses
	3	Charging contactor (R7i only)
	4	Charging resistors (R7i only; two resistors)
	5	Air guide
6	Connection to DC busbars	

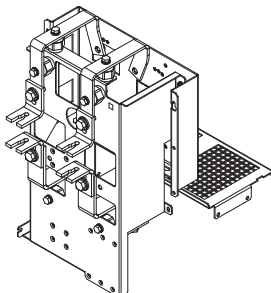
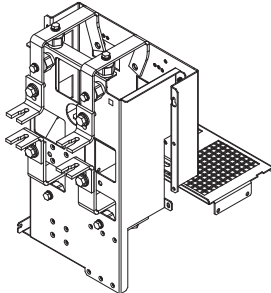
Used with...	Qty	Ordering code	Kit code	Illustration
Frame R6i without DC switch/disconnector	1	3AXD50000459094	A-4-67-283-VX	 <p>Instruction code: 3AXD50000444489</p>
Frame size R6i with DC switch/disconnector (IEC)	1	3AXD50000459100	A-4-6-281-VX	 <p>Instruction code: 3AXD50000445202</p>

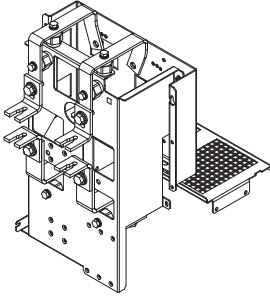
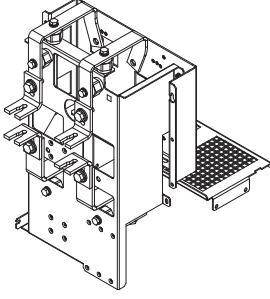
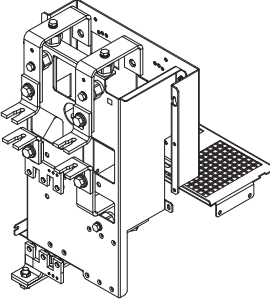
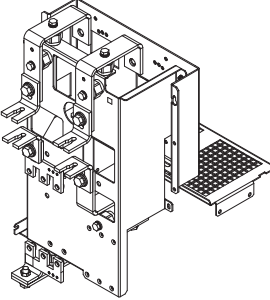
Used with...	Qty	Ordering code	Kit code	Illustration
<p>Frame size R6i with DC switch/disconnector (UL)</p>	<p>1</p>	<p>3AXD50000459117</p>	<p>A-4-6-285-VX</p>	 <p>Instruction code: 3AXD50000445325</p>
<p>Frame R7i without DC switch/disconnector or charging circuit</p>	<p>1</p>	<p>3AXD50000459094</p>	<p>A-4-67-283-VX</p>	 <p>Instruction code: 3AXD50000444489</p>
<p>Frame size R7i (400/500 V) without DC switch/disconnector, with charging circuit</p>	<p>1</p>	<p>3AXD50000459063</p>	<p>A-4-7-282-VX</p>	 <p>Instruction code: 3AXD50000445097</p>
<p>Frame size R7i (690 V) without DC switch/disconnector, with charging circuit</p>	<p>1</p>	<p>3AXD50000459087</p>	<p>A-4-7-287-VX</p>	 <p>Instruction code: 3AXD50000445332</p>

308 Ordering information

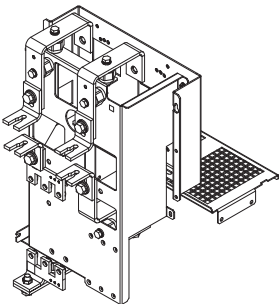
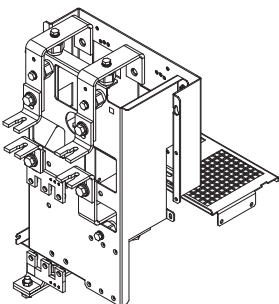
Used with...	Qty	Ordering code	Kit code	Illustration
Frame size R7i (400/500 V) with DC switch/disconnector and charging circuit	1	3AXD50000459056	A-4-7-280-VX	 <p>Instruction code: 3AXD50000445257</p>
Frame size R7i (690 V) with DC switch/disconnector and charging circuit	1	3AXD50000459070	A-4-7-286-VX	 <p>Instruction code: 3AXD50000445356</p>

DC busbars with common mode filter holder for Rittal VX25 enclosures

This kit contains the busbars that connect to the DC input of the inverter module. The busbars have a holder for the common mode filters; note that the filters shown in the illustration are not included in the kit.

Used with...	Qty	Ordering code	Kit code	Illustration
R6i R7i	1	3AXD50000458509	A-4-67-241-VX	 <p>Instruction code: 3AXD50000444304</p> <p>Note: Filters to be ordered separately</p>

DC busbars with fuse and common mode filter holders for generic enclosures

This kit contains the busbars that connect to the DC input of the inverter module. The kit is mounted onto the module. It has screws for cable lug connection as well as a holder for the DC fuses and common mode filters. Note that the fuses and filters are not included in the kit.

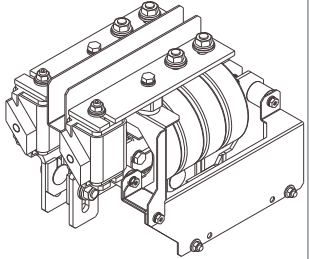
Used with...	Qty	Ordering code	Kit code	Illustration
R6i R7i	1	3AXD50000023329	A-0-67-244	 <p>Instruction code: 3AXD50000023500</p> <p>Note: Fuses and filters to be ordered separately</p>

Common mode filters

Common mode filtering reduces bearing currents and is required for electromagnetic compatibility (EMC). The filtering is implemented by installing two toroidal cores onto the DC busbars. The cores must be ordered separately.

Used with	Qty	Ordering code	Kit code	Illustration
All enclosure types	2 per module	3AUA0000032859	-	 <p>Instruction code: 3AUA0000123359</p>

■ AC-side components

AC busbar kit

This kit contains the busbars for connection of the motor cable. Note that the output (du/dt) filters (if required) are to be ordered separately (see further below).

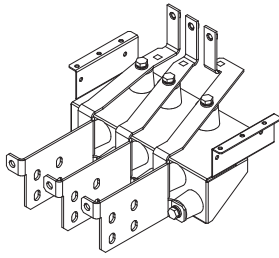
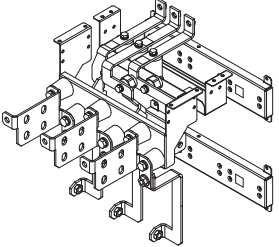
Used with...	Qty	Ordering code	Kit code	Illustration
R6i R7i (without output filters)	1	3AXD50000459032	A-4-67-181-VX	 <p>Instruction code: 3AXD50000452798</p>
R6i R7i (with output filters)	1	3AXD50000459049	A-4-67-186-VX	 <p>Instruction code: 3AXD50000452439</p> <p>Note: Filters to be ordered separately</p>

Output (du/dt) filters

For information on the usage of output (du/dt) filters, see [ACS880 multidrives cabinets and modules electrical planning instructions \(3AUA0000102324 \[English\]\)](#).

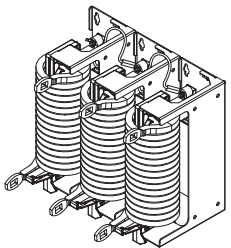
Used with...	Qty	Ordering code	Filter type	Illustration
R6i R7i	1	3AXD50000018892	BOCH-350A-7	 <p>Instruction code: 3AXD50000018989, 3AXD50000027070</p>

■ **Mechanical installation accessories and tools**

These kits include parts that are used for installing the inverter module in the Rittal VX25 enclosure.

Inverter module mounting parts

This kit contains the rails on which the inverter module rests, and provides air baffles for blocking unwanted air flow along the sides of the module.

Used with...	Qty	Ordering code	Kit code	Illustration
R6i R7i	1	3AXD50000459018	A-4-67-302-VX	 <p>Instruction code: 3AXD50000453337</p>

Shrouding

Used with...	Qty	Ordering code	Kit code	Illustration
R6i R7i	1	3AXD50000458493	A-4-67-350-VX	 <p>Instruction code: 3AXD50000453252</p>

Lifting device

Use the lifting device when replacing a module in the Rittal VX25 enclosure.

312 Ordering information

Frame	Enclosure	Qty	Ordering code	Illustration
<p>R6i R7i</p>	<p>Rittal VX25</p>	<p>1</p>	<p>3AXD50000439997</p>	 <p>Instruction code: 3AXD50000210268, 3AXD50000439409</p>

Frame R8i and multiples

■ Inverter modules

Inverter units consisting of frame R8i inverter modules are to be ordered as separate modules. For inverter unit ratings, see the technical data.

Inverter unit		Modules used	
Type	Frame size	Qty	Ordering code
$U_N = 400\text{ V}$			
ACS880-104-0470A-3	R8i	1	ACS880-104-0470A-3
ACS880-104-0640A-3	R8i	1	ACS880-104-0640A-3
ACS880-104-0760A-3	R8i	1	ACS880-104-0760A-3
ACS880-104-0830A-3	R8i	1	ACS880-104-0830A-3
ACS880-104-0900A-3	R8i	1	ACS880-104-0900A-3
ACS880-104-1250A-3	2×R8i	2	ACS880-104-0640A-3 +E205
ACS880-104-1480A-3	2×R8i	2	ACS880-104-0760A-3 +E205
ACS880-104-1760A-3	2×R8i	2	ACS880-104-0900A-3 +E205
ACS880-104-2210A-3	3×R8i	3	ACS880-104-0760A-3 +E205
ACS880-104-2610A-3	3×R8i	3	ACS880-104-0900A-3 +E205
ACS880-104-3450A-3	4×R8i	4	ACS880-104-0900A-3 +E205
ACS880-104-4290A-3	5×R8i	5	ACS880-104-0900A-3 +E205
ACS880-104-5130A-3	6×R8i	6	ACS880-104-0900A-3 +E205
$U_N = 500\text{ V}$			
ACS880-104-0440A-5	R8i	1	ACS880-104-0440A-5
ACS880-104-0590A-5	R8i	1	ACS880-104-0590A-5
ACS880-104-0670A-5	R8i	1	ACS880-104-0670A-5
ACS880-104-0740A-5	R8i	1	ACS880-104-0740A-5
ACS880-104-0810A-5	R8i	1	ACS880-104-0810A-5
ACS880-104-1150A-5	2×R8i	2	ACS880-104-0590A-5 +E205
ACS880-104-1450A-5	2×R8i	2	ACS880-104-0740A-5 +E205
ACS880-104-1580A-5	2×R8i	2	ACS880-104-0810A-5 +E205
ACS880-104-2150A-5	3×R8i	3	ACS880-104-0740A-5 +E205
ACS880-104-2350A-5	3×R8i	3	ACS880-104-0810A-5 +E205
ACS880-104-3110A-5	4×R8i	4	ACS880-104-0810A-5 +E205
ACS880-104-3860A-5	5×R8i	5	ACS880-104-0810A-5 +E205
ACS880-104-4610A-5	6×R8i	6	ACS880-104-0810A-5 +E205

314 Ordering information

Inverter unit		Modules used	
Type	Frame size	Qty	Ordering code
U _N = 690 V			
ACS880-104-0340A-7	R8i	1	ACS880-104-0340A-7 +E205
ACS880-104-0410A-7	R8i	1	ACS880-104-0410A-7 +E205
ACS880-104-0480A-7	R8i	1	ACS880-104-0480A-7 +E205
ACS880-104-0530A-7	R8i	1	ACS880-104-0530A-7 +E205
ACS880-104-0600A-7	R8i	1	ACS880-104-0600A-7 +E205
ACS880-104-0800A-7	2×R8i	2	ACS880-104-0410A-7 +E205
ACS880-104-1030A-7	2×R8i	2	ACS880-104-0530A-7 +E205
ACS880-104-1170A-7	2×R8i	2	ACS880-104-0600A-7 +E205
ACS880-104-1540A-7	3×R8i	3	ACS880-104-0530A-7 +E205
ACS880-104-1740A-7	3×R8i	3	ACS880-104-0600A-7 +E205
ACS880-104-2300A-7	4×R8i	4	ACS880-104-0600A-7 +E205
ACS880-104-2860A-7	5×R8i	5	ACS880-104-0600A-7 +E205
ACS880-104-3420A-7	6×R8i	6	ACS880-104-0600A-7 +E205
ACS880-104-3990A-7	7×R8i	7	ACS880-104-0600A-7 +E205
ACS880-104-4560A-7	8×R8i	8	ACS880-104-0600A-7 +E205
ACS880-104-5130A-7	9×R8i	9	ACS880-104-0600A-7 +E205
ACS880-104-5700A-7	10×R8i	10	ACS880-104-0600A-7 +E205

Ordering code format	Option codes
[Module type] +code [+code] ... For example, ACS880-104-0470A-3 +E205 +C132	For available options, refer to Type designation key (page 52) .

Note: The following components are also required to construct a working inverter unit and must be ordered separately:

- An ACS-AP-x control panel is required for the commissioning of an ACS880 drive system, even if the Drive composer PC tool is used. See section ACS-AP-W control panel below.
- Inverter control unit (refer to section Inverter control unit below)
- Fiber optic cabling from control unit to each inverter module (refer to section Fiber-optic cables below)
- Common mode filters
- Control circuit plug connectors
- Quick connector.

The other parts listed in this chapter for this frame size

- may be required by the application (such as a DC switch/disconnector), or
 - make the installation or use of the module easier.
-

Control panel

The control panel is not included with the module but must be ordered separately. One control panel is required for the commissioning of an ACS880 drive system, even if the Drive Composer PC tool is used.

The control panel can be flush mounted on the cabinet door with the help of a door mounting kit. For more information on the control panel, refer to [ACS-AP-I, -S, -W and ACH-AP-H, -W Assistant control panels user's manual \(3AUA0000085685 \[English\]\)](#).

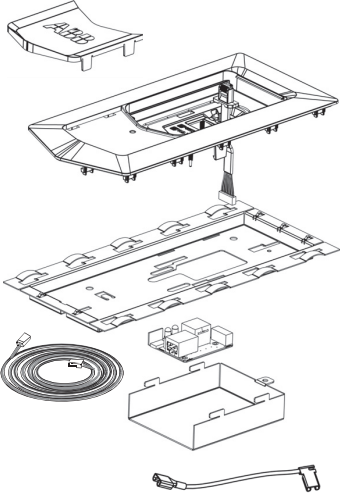
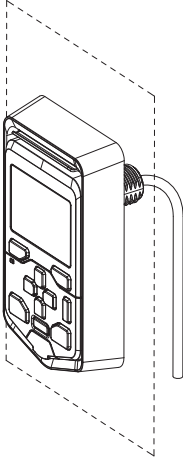
Type	Description	Ordering code	Illustration
ACS-AP-W	Control panel with Bluetooth	3AXD50000025965	
DPMP-01	Door mounting kit (IP55)	3AUA0000108878	
DPMP-02	Door mounting kit (IP65)	3AXD50000009374	

For more information on the door mounting kits, such as the contents of the kit, refer to the installation manuals:

- [DPMP-01 mounting platform for control panels installation guide \(3AUA0000100140 \[English\]\)](#)
- [DPMP-02/03 mounting platform for control panels installations guide \(3AUA0000136205 \[English\]\)](#).

■ Control electronics

Control unit (UCU-22...24)

One UCU-22...24 control unit is required per inverter unit. The type of the control unit depends on the number of inverter modules as shown below. The control unit is delivered with a memory unit containing the ACS880 primary control program, optionally with application programmability. For availability of other control programs, contact your local ABB representative.

Frame size	Control unit type	Ordering code
R8i, 2×R8i	UCU-22	ACS880UCU-104-22-0
3×R8i...8×R8i	UCU-23	ACS880UCU-104-23-0
9×R8i...10×R8i	UCU-24	ACS880UCU-104-24-0

Ordering code format	Option codes
[Control unit type] + code [+code]... For example, ACS880UCU-104-22-0+N8010	+N8010: Application programming

The UCU-22...24 control unit kit contains:

- UCU-22, UCU-23 or UCU-24 control unit with USCA-02 adapters.
- UMU-01 memory unit with the control program.

Control unit (BCU)

One BCU control unit is required per inverter unit. The type of the control unit depends on the number of inverter modules as shown below. The control unit is delivered with a memory unit containing the ACS880 primary control program, optionally with application programmability. For availability of other control programs, contact your local ABB representative.

Frame size	Control unit type	Application programmability	Ordering code
R8i, 2×R8i	BCU-02	No	3AXD50000003417
		Yes ¹⁾	3AXD50000011540
3×R8i...7×R8i	BCU-12	No	3AXD50000006340
		Yes ¹⁾	3AXD50000011541

318 Ordering information

Frame size	Control unit type	Application program-mability	Ordering code
8×R8i...10×R8i	BCU-22	No	3AXD50000011543
		Yes ¹⁾	3AXD50000011544

¹⁾ Application programmability using function blocks based on the IEC 61131-3 standard. For more information, see [Programming manual: Drive application programming \(IEC 61131-3\) \(3AUA0000127808 \[English\]\)](#).

Fiber-optic cables

Each frame R8i module is connected to the inverter control unit with a pair of fiber optic cables.

If the inverter unit is equipped with a DC switch/disconnector, each inverter module is also connected to the charging controller by a pair of fiber optic cables.

Each of the kits in the table below contain a pair of plastic fiber-optic cables that are needed in communication between the control unit and the power (inverter/supply/brake/converter) module.

Length	Kit type designation	Ordering code
2 m (6.6 ft)	NLWC-02	58988821
3 m (9.8 ft)	NLWC-03	58948233
5 m (16.4 ft)	NLWC-05	58948250
7 m (23 ft)	NLWC-07	58948268
10 m (32.8 ft)	NLWC-10	58948276

Control circuit plug connectors

The control circuit plug for connector X50 is not included in the module kit and you must order it separately.

Note: Plug connectors for X51, X52 and X53 are included in the module kit.

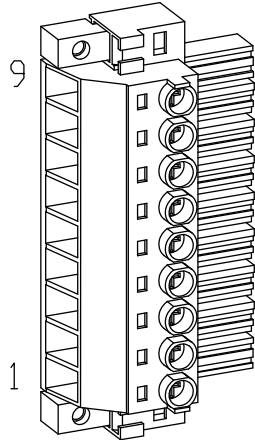
Connector	Data	Qty	Ordering code	Illustration
X50 for R8i modules with +V112	BVZ 7.62HP/09/180FC SN BK BX LRP 9-pole (female) 10 mm ² , 1000 V, 57 A (UL/CSA: 600 V, 40.5 A)	1 per module	3AXD50000960248	

Wire sets for use with the reduced run function

A “reduced run” function (for inverter unit frame sizes 3×R8i and above) makes it possible to continue operation with limited current even if some modules of the

inverter unit are out of service. The wire set for the STO connection is available as shown below.

Use	Qty	Ordering code	Data
STO wiring in place of removed inverter module	1 per module	3AXD50000022694	PVC insulation
		3AXD50000022695	Halogen-free insulation

■ DC-side components

Frame R8i modules are connected to the DC bus through fuses. The design presented in this manual has flush-end fuse blocks bolted to the DC busbars.

A DC switch/disconnector can be installed if quick isolation of the module from the DC bus is required. One of the auxiliary contacts of the switch is used for monitoring the open/closed state of the switch. A capacitor charging circuit is to be installed with the DC switch/disconnector.

Note: A separate capacitor charging circuit must be designed and installed by the customer if the inverter unit is directly connected to the DC bus and the supply unit of the system does not have a charging capability.

The common mode filters are mounted onto the busbars that connect to the DC input of the inverter module.

DC bus installation parts (for Rittal VX25 enclosures)

The brackets in this kit act as a mounting base for the busbar supports of the Rittal Flat-PLS DC link and ensure its correct placement and alignment inside the cabinet line-up.

The designs shown in this manual for Rittal VX25 enclosures use the Rittal Flat-PLS busbar system. Make sure that the current in the drive system does not exceed the current-carrying capacity of the busbars.

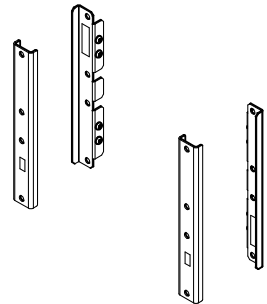
Used with ...	Qty	Ordering code	Kit code	Illustration
VX25 enclosure	1 kit per cubicle	3AXD50000333387	A-468-X-001-VX	 <p>Instruction code: 3AXD50000333639</p>

DC connection parts 1 of 2 (for Rittal VX25 enclosures)

These parts connect the Flat-PLS busbars to the DC fuses, and provide the mounting base for the charging components if required.

320 Ordering information

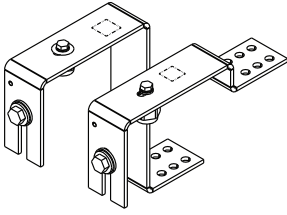
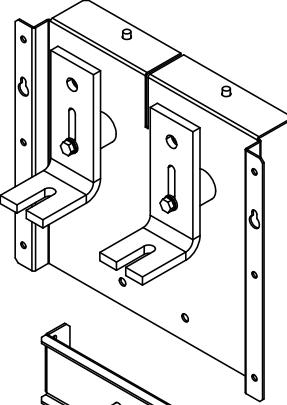
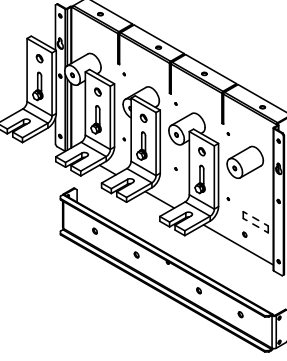
Used with...	Qty	Ordering code	Kit code	Illustration
400/600 mm VX25 enclosure without DC switch/disconnector and charging	1 per module	3AXD50000337446	A-46-8-206-VX	 <p data-bbox="1054 539 1246 584">Instruction code: 3AXD50000345915</p>
400 mm VX25 enclosure without DC switch/disconnector and charging	1	3AXD50000337415	A-4-8-252-VX	 <p data-bbox="1054 1167 1246 1211">Instruction code: 3AXD50000345151</p>
600 mm VX25 enclosure without DC switch/disconnector and charging	1	3AXD50000337521	A-6-8-255-VX	 <p data-bbox="1054 1648 1246 1693">Instruction code: 3AXD50000342471</p>

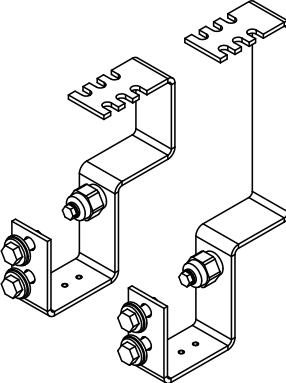
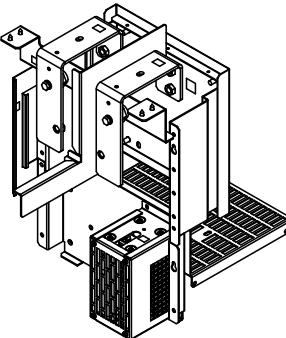
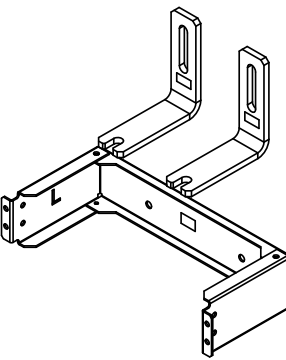
Used with...	Qty	Ordering code	Kit code	Illustration
400/600 mm VX25 enclosure with DC switch/disconnector and charging	1 per module	3AXD50000337453	A-46-8-207-VX	 <p data-bbox="1204 705 1396 750">Instruction code: 3AXD50000345458</p>
400 mm VX25 enclosure with DC switch/disconnector and charging	1	3AXD50000337439	A-4-8-288-VX	 <p data-bbox="1204 1153 1396 1198">Instruction code: 3AXD50000342501</p>
400 mm VX25 enclosure with DC switch/disconnector and charging	1	3AXD50000337422	A-4-8-290-VX	 <p data-bbox="1204 1624 1396 1668">Instruction code: 3AXD50000345236</p>

322 Ordering information

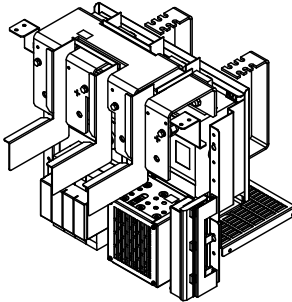
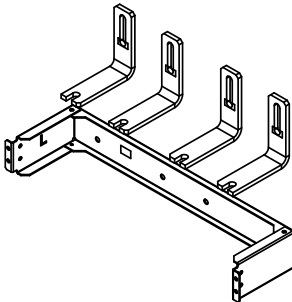
Used with...	Qty	Ordering code	Kit code	Illustration
600 mm VX25 enclosure with DC switch/disconnector and charging	1	3AXD50000337545	A-6-8-289-VX	 <p>Instruction code: 3AXD50000342860</p>
	1	3AXD50000337538	A-6-8-291-VX	 <p>Instruction code: 3AXD50000342983</p>

DC connection parts 1 of 2 (for generic enclosures)

These parts provide the DC connection between the input busbars and the DC fuses (including a mounting base for the charging components if required).

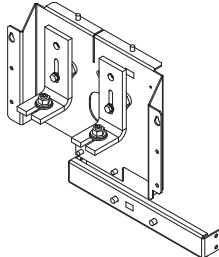
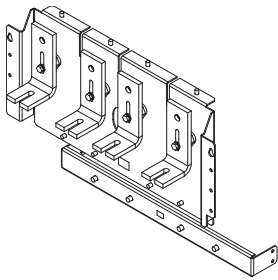
Used with...	Qty	Ordering code	Kit code	Illustration
400 mm generic enclosure without DC switch/disconnector and charging	1	3AXD50000006418	A-4-8-256	 <p>Instruction code: 3AXD50000006441</p>
600 mm generic enclosure without DC switch/disconnector and charging	1	3AXD50000006444	A-6-8-257	 <p>Instruction code: 3AXD50000006447</p>

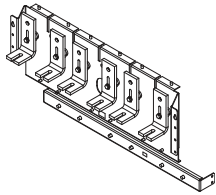
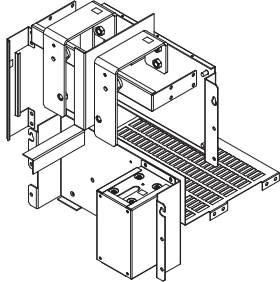
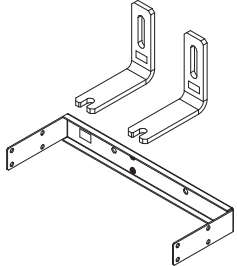
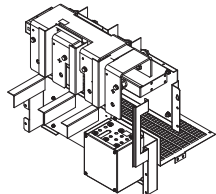
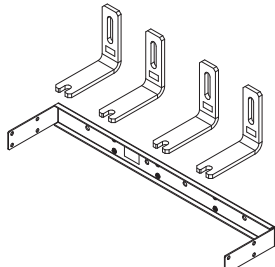
Used with...	Qty	Ordering code	Kit code	Illustration
800 mm generic enclosure without DC switch/disconnector and charging	1	3AXD5000006450	A-8-8-258	 <p data-bbox="1203 488 1401 539">Instruction code: 3AXD5000006455</p>
400 mm generic enclosure with DC switch/disconnector and charging	1	3AXD50000044559	A-4-8-292	 <p data-bbox="1203 855 1401 907">Instruction code: 3AXD50000043644</p>
	1	3AXD50000044582	A-4-8-295	 <p data-bbox="1203 1209 1401 1261">Instruction code: 3AXD50000043686</p>
600 mm generic enclosure with DC switch/disconnector and charging	1	3AXD50000044560	A-6-8-293	 <p data-bbox="1203 1489 1401 1541">Instruction code: 3AXD50000043784</p>
	1	3AXD50000044583	A-6-8-296	 <p data-bbox="1203 1848 1401 1899">Instruction code: 3AXD50000043737</p>

324 Ordering information

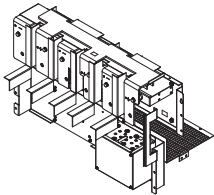
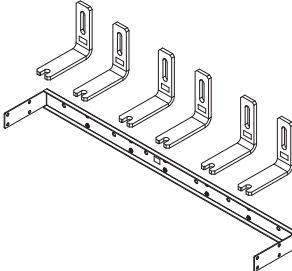
Used with...	Qty	Ordering code	Kit code	Illustration
800 mm generic enclosure with DC switch/disconnector and charging	1	3AXD50000044581	A-8-8-294	 <p>Instruction code: 3AXD50000044586</p>
	1	3AXD50000044584	A-8-8-297	 <p>Instruction code: 3AXD50000044574</p>

DC connection parts 2 of 2 (for Rittal VX25 or generic enclosures)

These parts connect the DC fuses to the inverter module.

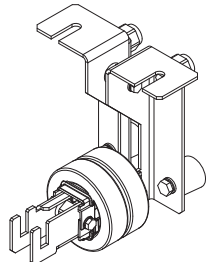
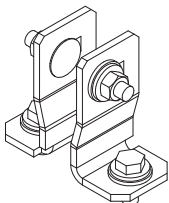
Used with...	Qty	Ordering code	Kit code	Illustration
All VX25 and generic enclosures without DC switch/disconnector and charging	1 per module	3AXD50000028401	A-468-8-235	 <p>Instruction code: 3AXD50000028418</p> <p>Note: Filters to be ordered separately</p>
	1 per module	3AXD50000028403	A-468-8-246	 <p>Instruction code: 3AXD50000028384</p>

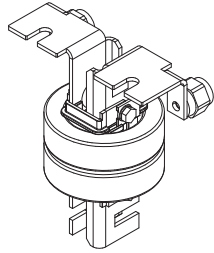
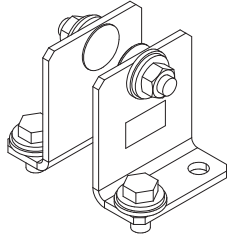
Used with...	Qty	Ordering code	Kit code	Illustration
All VX25 and generic enclosures with DC switch/disconnector and charging	1 per module	3AXD50000044551	A-468-8-247	 <p>Instruction code: 3AXD50000043411</p> <p>Note: Filters to be ordered separately</p>
	1 per module	3AXD50000044553	A-468-8-248	 <p>Instruction code: 3AXD50000043466</p>

Common mode filters

Common mode filtering reduces bearing currents and is required for electromagnetic compatibility (EMC). The filtering is implemented by installing two toroidal cores onto the DC busbars. The cores must be ordered separately.

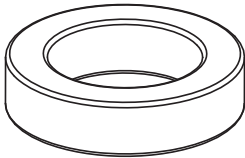
Used with	Qty	Ordering code	Kit code	Illustration
All enclosure types	2 per module	3AUA0000032859	-	 <p>Instruction code: 3AUA0000123359</p>

DC fuses (IEC, UL)

Unit type ACS880-104-...			Fuse				
			Qty	Ordering code	Type	Data	Size
0470A-3			2	3AXD50000000148	170M6413	900 A, 690 V	3
0640A-3			2	68244463	170M6416	1250 A, 690 V	3
0760A-3			2	3AXD50000000150	170M6417	1400 A, 690 V	3
0830A-3			2	68393108	170M6419	1600 A, 690 V	3*
0900A-3							
1250A-3			4	68244463	170M6416	1250 A, 690 V	3
1480A-3			4	3AXD50000000150	170M6417	1400 A, 690 V	3

326 Ordering information

Unit type ACS880-104-...			Fuse				
			Qty	Ordering code	Type	Data	Size
1760A-3			4	68393108	170M6419	1600 A, 690 V	3*
2210A-3			6	3AXD50000000150	170M6417	1400 A, 690 V	3
2610A-3			6	68393108	170M6419	1600 A, 690 V	3*
3450A-3			8				
4290A-3			10				
5130A-3			12				
	0440A-5		2	3AXD50000000148	170M6413	900 A, 690 V	3
	0590A-5		2	68731658	170M6415	1100 A, 690 V	3
	0670A-5 0740A-5 0810A-5		2	3AXD50000000150	170M6417	1400 A, 690 V	3
	1150A-5		4	68731658	170M6415	1100 A, 690 V	3
	1450A-5 1580A-5		4	3AXD50000000150	170M6417	1400 A, 690 V	3
	2150A-5 2350A-5		6				
	3110A-5		8				
	3860A-5		10				
	4610A-5		12				
		0340A-7	2	63903167	170M6544	630 A, 1250 V	3
		0410A-7	2	63919128	170M6546	800 A, 1250 V	3
		0480A-7 0530A-7	2	63916749	170M6548	1000 A, 1100 V	3
		0600A-7	2	68736021	170M6549	1100 A, 1000 V	3
		0800A-7	4	63919128	170M6546	800 A, 1250 V	3
		1030A-7	4	63916749	170M6548	1000 A, 1100 V	3
		1170A-7	4	68736021	170M6549	1100 A, 1000 V	3
		1540A-7	6	63916749	170M6548	1000 A, 1100 V	3
		1740A-7	6	68736021	170M6549	1100 A, 1000 V	3
		2300A-7	8				
		2860A-7	10				
		3420A-7	12				
		3990A-7	14				
		4560A-7	16				
		5130A-7	18				
		5700A-7	20				

DC switch/disconnector kits

IEC – 230 V 50 Hz						
Unit type ACS880-104-...			Enclosure type	Qty	Ordering code	Switch type
0470A-3	0440A-5	0340A-7	Rittal VX25 or generic	1	3AXD50000009534	OT1600E11
0640A-3	0590A-5	0410A-7				
0760A-3	0670A-5	0480A-7				
0830A-3	0740A-5	0530A-7				
0900A-3	0810A-5	0600A-7				
1250A-3	1150A-5	0800A-7	Rittal VX25 or generic	1	3AXD50000009535	OT1600E22
1480A-3	1450A-5	1030A-7				
1760A-3	1580A-5	1170A-7				
2210A-3 2610A-3	2150A-5 2350A-5	1540A-7 1740A-7	Rittal VX25	1	3AXD50000009534	OT1600E11
				1	3AXD50000009535	OT1600E22
			Generic	1	3AXD50000009536	OT2500E22
3450A-3	3110A-5	2300A-7	Rittal VX25 or generic	2	3AXD50000009535	OT1600E22
4290A-3	3860A-5	2860A-7	Rittal VX25	1	3AXD50000009534	OT1600E11
				2	3AXD50000009535	OT1600E22
			Generic	1	3AXD50000009535	OT1600E22
				1	3AXD50000009536	OT2500E22
5130A-3	4610A-5	3420A-7	Rittal VX25	3	3AXD50000009535	OT1600E22
			Generic	2	3AXD50000009536	OT2500E22
3990A-7			Rittal VX25	1	3AXD50000009534	OT1600E11
				3	3AXD50000009535	OT1600E22
			Generic	2	3AXD50000009535	OT1600E22
				1	3AXD50000009536	OT2500E22
4560A-7			Rittal VX25	4	3AXD50000009535	OT1600E22
			Generic	1	3AXD50000009535	OT1600E22
				2	3AXD50000009536	OT2500E22
5130A-7			Rittal VX25	1	3AXD50000009534	OT1600E11
				4	3AXD50000009535	OT1600E22
			Generic	3	3AXD50000009536	OT2500E22
5700A-7			Rittal VX25	5	3AXD50000009535	OT1600E22
			Generic	2	3AXD50000009535	OT1600E22
				2	3AXD50000009536	OT2500E22

328 Ordering information

IEC – 230 V 60 Hz						
Unit type ACS880-104-...			Enclosure type	Qty	Ordering code	Switch type
0470A-3	0440A-5	0340A-7	Rittal VX25 or generic	1	3AXD50000026854	OT1600E11
0640A-3	0590A-5	0410A-7				
0760A-3	0670A-5	0480A-7				
0830A-3	0740A-5	0530A-7				
0900A-3	0810A-5	0600A-7				
1250A-3	1150A-5	0800A-7	Rittal VX25 or generic	1	3AXD50000026857	OT1600E22
1480A-3	1450A-5	1030A-7				
1760A-3	1580A-5	1170A-7				
2210A-3 2610A-3	2150A-5 2350A-5	1540A-7	Rittal VX25	1	3AXD50000026854	OT1600E11
				1	3AXD50000026857	OT1600E22
		1740A-7	Generic	1	3AXD50000026860	OT2500E22
3450A-3	3110A-5	2300A-7	Rittal VX25 or generic	2	3AXD50000026857	OT1600E22
4290A-3	3860A-5	2860A-7	Rittal VX25	1	3AXD50000026854	OT1600E11
				2	3AXD50000026857	OT1600E22
			Generic	1	3AXD50000026857	OT1600E22
				1	3AXD50000026860	OT2500E22
5130A-3	4610A-5	3420A-7	Rittal VX25	3	3AXD50000026857	OT1600E22
			Generic	2	3AXD50000026860	OT2500E22
3990A-7			Rittal VX25	1	3AXD50000026854	OT1600E11
				3	3AXD50000026857	OT1600E22
			Generic	2	3AXD50000026857	OT1600E22
				1	3AXD50000026860	OT2500E22
4560A-7			Rittal VX25	4	3AXD50000026857	OT1600E22
			Generic	1	3AXD50000026857	OT1600E22
				2	3AXD50000026860	OT2500E22
5130A-7			Rittal VX25	1	3AXD50000026854	OT1600E11
				4	3AXD50000026857	OT1600E22
			Generic	3	3AXD50000026860	OT2500E22
5700A-7			Rittal VX25	5	3AXD50000026857	OT1600E22
			Generic	2	3AXD50000026857	OT1600E22
				2	3AXD50000026860	OT2500E22

UL – 115 V 60 Hz						
Unit type ACS880-104-...			Enclosure type	Qty	Ordering code	Switch type
0470A-3	0440A-5	0340A-7	Rittal VX25 or generic	1	3AXD50000009540	OT1200U11
0640A-3	0590A-5	0410A-7				
0760A-3	0670A-5	0480A-7				
0830A-3	0740A-5	0530A-7				
0900A-3	0810A-5	0600A-7				
1250A-3	1150A-5	0800A-7	Rittal VX25 or generic	1	3AXD50000009541	OT1200U22
1480A-3	1450A-5	1030A-7				
1760A-3	1580A-5	1170A-7				
2210A-3	2150A-5	1540A-7	Rittal VX25 or generic	1	3AXD50000009540	OT1200U11
2610A-3	2350A-5	1740A-7		1	3AXD50000009541	OT1200U22
3450A-3	3110A-5	2300A-7	Rittal VX25 or generic	2	3AXD50000009541	OT1200U22
4290A-3	3860A-5	2860A-7	Rittal VX25 or generic	1	3AXD50000009540	OT1200U11
				2	3AXD50000009541	OT1200U22
5130A-3	4610A-5	3420A-7	Rittal VX25 or generic	3	3AXD50000009541	OT1200U22
3990A-7			Rittal VX25 or generic	1	3AXD50000009540	OT1200U11
				3	3AXD50000009541	OT1200U22
4560A-7			Rittal VX25 or generic	4	3AXD50000009541	OT1200U22
5130A-7			Rittal VX25 or generic	1	3AXD50000009540	OT1200U11
				4	3AXD50000009541	OT1200U22
5700A-7			Rittal VX25 or generic	5	3AXD50000009541	OT1200U22

Kit contents:

- DC switch/disconnector(s)
- Shaft (12 × 395 mm)
- OHB150J12P (switch types ...11) or OHB274J12 (switch types ...22) handle with off/on indication
- Interlock kit OTZT4A with PDAL2 coil
- One normally-open (OA1G10) and one normally-closed (OA3G01) auxiliary contact block.

Charging kits

The charging kit contains the main parts of the charging circuit, such as the charging switch (with shaft, handle, terminal shrouds and a set of auxiliary contacts), fuses, connectors and the charging controller. Note that the charging resistors or fiber optic cables are not included in the kit and must be ordered separately.

330 Ordering information

IEC					
Unit type ACS880-104-...			Enclosure type	Qty	Ordering code
0470A-3	0440A-5	0340A-7	Rittal VX25 or generic	1	3AXD50000009537
0640A-3	0590A-5	0410A-7			
0760A-3	0670A-5	0480A-7			
0830A-3	0740A-5	0530A-7			
0900A-3	0810A-5	0600A-7			
1250A-3	1150A-5	0800A-7			
1480A-3	1450A-5	1030A-7			
1760A-3	1580A-5	1170A-7			
2210A-3	2150A-5	1540A-7	Rittal VX25	2	3AXD50000009537
2610A-3	2350A-5	1740A-7	Generic	1	3AXD50000009539
3450A-3	3110A-5	2300A-7	Rittal VX25 or generic	2	3AXD50000009537
4290A-3	3860A-5	2860A-7	Rittal VX25	3	3AXD50000009537
			Generic	1	3AXD50000009537
				1	3AXD50000009539
5130A-3	4610A-5	3420A-7	Rittal VX25	3	3AXD50000009537
			Generic	2	3AXD50000009539
3990A-7			Rittal VX25	4	3AXD50000009537
			Generic	2	3AXD50000009537
				1	3AXD50000009539
4560A-7			Rittal VX25	4	3AXD50000009537
			Generic	1	3AXD50000009537
				2	3AXD50000009539
5130A-7			Rittal VX25	5	3AXD50000009537
			Generic	3	3AXD50000009539
5700A-7			Rittal VX25	5	3AXD50000009537
			Generic	2	3AXD50000009537
				2	3AXD50000009539

UL					
Unit type ACS880-104-...			Enclosure type	Qty	Ordering code
0470A-3	0440A-5	0340A-7	Rittal VX25 or generic	1	3AXD50000009538
0640A-3	0590A-5	0410A-7			
0760A-3	0670A-5	0480A-7			
0830A-3	0740A-5	0530A-7			
0900A-3	0810A-5	0600A-7			
1250A-3	1150A-5	0800A-7			
1480A-3	1450A-5	1030A-7			
1760A-3	1580A-5	1170A-7			
2210A-3	2150A-5	1540A-7	Rittal VX25 or generic	2	3AXD50000009538
2610A-3	2350A-5	1740A-7			
3450A-3	3110A-5	2300A-7			
4290A-3	3860A-5	2860A-7	Rittal VX25 or generic	3	3AXD50000009538
5130A-3	4610A-5	3420A-7			
3990A-7			Rittal VX25 or generic	4	3AXD50000009538
4560A-7			Rittal VX25 or generic	4	3AXD50000009538
5130A-7			Rittal VX25 or generic	5	3AXD50000009538
5700A-7			Rittal VX25 or generic	5	3AXD50000009538

Kit contents:

Ordering code	Contents
3AXD50000009537	Switch fuse (OS160GD04F) with terminal shrouds (OSS160GT1S/4); shaft (6 × 290 mm); OHB65J6 handle; normally-closed auxiliary contacts (OA3G01, 2 pcs); 170M2676 fuses; charging controller
3AXD50000009538	Switch fuse (OS100GJ04FP) with terminal shrouds (OSS160GT1S/4); shaft (6 × 161 mm); OHB65J6 handle; normally-closed auxiliary contacts (OA3G01, 2 pcs); FWJ30A fuses and fuse holder modification parts; charging controller
3AXD50000009539	Switch fuse (OS200DZ22F) with terminal shrouds (OSS200G1S/4); shaft (6 × 210 mm); OHB65J6 handle; normally-closed auxiliary contacts (OA3G01, 2 pcs); 170M2676 fuses; charging controller

- Charging resistors are not included and must be ordered separately. See below.
- The charging controller connects to each inverter module by a pair of fiber optic cables. The cables are not included and must be ordered separately.

Charging resistors

IEC						
Unit type ACS880-104-...			Enclosure type	Qty	Ordering code	Data
0470A-3	0440A-5		Rittal VX25 or generic	4	10037531	24 Ω
0640A-3	0590A-5					
0760A-3	0670A-5					
0830A-3	0740A-5					
0900A-3	0810A-5					
1250A-3	1150A-5		Rittal VX25 or generic	6	10037531	24 Ω
1480A-3	1450A-5					
1760A-3	1580A-5					
2210A-3	2150A-5		Rittal VX25	10	10037531	24 Ω
2610A-3	2350A-5		Generic	8		
3450A-3	3110A-5		Rittal VX25 or generic	12	10037531	24 Ω
4290A-3	3860A-5		Rittal VX25	16	10037531	24 Ω
			Generic	14		
5130A-3	4610A-5		Rittal VX25	18	10037531	24 Ω
			Generic	16		
		0340A-7 0410A-7 0480A-7 0530A-7 0600A-7	Rittal VX25 or generic	4	10028531	33 Ω
		0800A-7 1030A-7 1170A-7	Rittal VX25 or generic	6	10028531	33 Ω
		1540A-7 1740A-7	Rittal VX25	10	10028531	33 Ω
			Generic	8		
		2300A-7	Rittal VX25 or generic	12	10028531	33 Ω
		2860A-7	Rittal VX25	16	10028531	33 Ω
			Generic	14		
		3420A-7	Rittal VX25	18	10028531	33 Ω
			Generic	16		
		3990A-7	Rittal VX25	22	10028531	33 Ω
			Generic	20		
		4560A-7	Rittal VX25	24	10028531	33 Ω
			Generic	22		

IEC						
Unit type ACS880-104-...			Enclosure type	Qty	Ordering code	Data
		5230A-7	Rittal VX25	28	10028531	33 Ω
			Generic	24		
		5700A-7	Rittal VX25	30	10028531	33 Ω
			Generic	28		

UL						
Unit type ACS880-104-...			Enclosure type	Qty	Ordering code	Data
0470A-3	0440A-5		Rittal VX25 or generic	4	10037531	24 Ω
0640A-3	0590A-5					
0760A-3	0670A-5					
0830A-3	0740A-5					
0900A-3	0810A-5					
1250A-3	1150A-5		Rittal VX25 or generic	6	10037531	24 Ω
1480A-3	1450A-5					
1760A-3	1580A-5					
2210A-3	2150A-5		Rittal VX25 or generic	10	10037531	24 Ω
2610A-3	2350A-5					
3450A-3	3110A-5		Rittal VX25 or generic	12	10037531	24 Ω
4290A-3	3860A-5		Rittal VX25 or generic	16	10037531	24 Ω
5130A-3	4610A-5		Rittal VX25 or generic	18	10037531	24 Ω
		0340A-7 0410A-7 0480A-7 0530A-7 0600A-7	Rittal VX25 or generic	4	10028531	33 Ω
		0800A-7 1030A-7 1170A-7	Rittal VX25 or generic	6	10028531	33 Ω
		1540A-7 1740A-7	Rittal VX25 or generic	10	10028531	33 Ω
		2300A-7	Rittal VX25 or generic	12	10028531	33 Ω
		2860A-7	Rittal VX25 or generic	16	10028531	33 Ω
		3420A-7	Rittal VX25 or generic	18	10028531	33 Ω

UL					
Unit type ACS880-104-...		Enclosure type	Qty	Ordering code	Data
	3990A-7	Rittal VX25 or generic	22	10028531	33 Ω
	4560A-7	Rittal VX25 or generic	24	10028531	33 Ω
	5130A-7	Rittal VX25 or generic	28	10028531	33 Ω
	5700A-7	Rittal VX25 or generic	30	10028531	33 Ω

■ AC-side components

Quick connector

The three-phase power connection to the inverter/supply/brake/converter module through a quick connector.

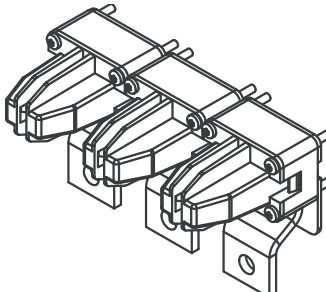
Used with	Qty	Ordering code	Kit code	Illustration
All enclosure types	1 per module	3AUA0000119227	A-468-8-100	 <p>Instruction code: 3AUA0000118667</p>

Output busbars/shrouds kit

This kit contains the busbars that connect to the quick connector(s), the busbars for the motor cable connection, and shrouding.

The following types of kits are available:

1. Kits with cable connections (all enclosure types).
Each inverter module has its own motor cable connections. If the inverter unit consists of parallel-connected modules, each module must be separately (and identically) cabled to the motor.
2. Kits with bridging busbars (600 mm VX25 or generic enclosures, 800 mm generic enclosures).
These kits connect the outputs of the modules in the same cubicle so that, for example, a single thicker cable can be used instead of separate cables for each module.



⚠WARNING The bridging can carry the nominal output of one inverter module. In case of three parallel modules, ensure that the load capacity of the bridging is not exceeded. For example, if the cabling connects to the output busbars at one module only, use the module in the middle.

If the inverter unit consists of modules installed in different cubicles, make sure that the load is distributed evenly between the modules:

- In case of two inverter cubicles of two modules, connect the same number of cables to each cubicle.
- In case of one inverter cubicle with three modules and another with two, each cubicle requires a number of cables proportional to the number of modules within. For example, connect three out of five (or six out of ten, etc.) cables to the cubicle with three modules, the remaining two out of five (four out of ten) cables to the cubicle with two modules.

3. Kits with common AC output busbars (400 and 600 mm wide VX25 enclosures). These kits have connection points for busbars that join the outputs of inverter modules regardless of whether the modules are located in the same cubicle or not. Using these kits, it is possible to construct a common output cubicle where all motor cables connect to.

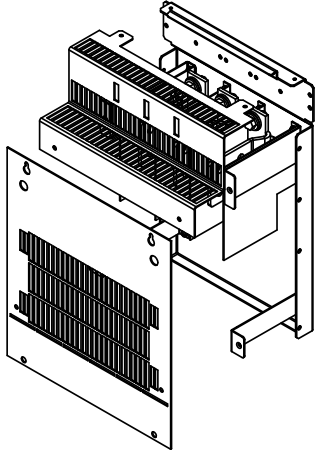
Used with...	Qty	Ordering code	Kit code	Illustration
400 mm VX25 enclosure (cable connection)	1	3AXD50000337477	A-4-8-132-VX	 <p>Instruction code: 3AXD50000343492</p>

336 Ordering information

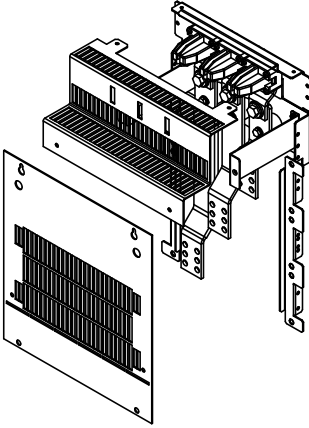
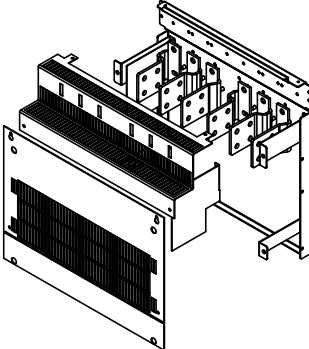
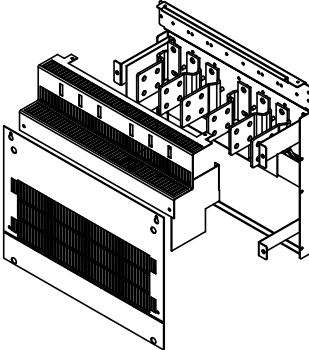
Used with...	Qty	Ordering code	Kit code	Illustration
400 mm VX25 enclosure (common AC output busbar connection)	1	3AXD50000337088	A-4-8-140-VX	 <p data-bbox="1043 745 1238 795">Instruction code: 3AXD50000337088</p>
600 mm VX25 enclosure (cable connection)	1	3AXD50000337569	A-6-8-133-VX	 <p data-bbox="1043 1211 1238 1261">Instruction code: 3AXD50000345526</p>
600 mm VX25 enclosure (cable connection with bridging busbars)	1	3AXD50000337576	A-6-8-134-VX	 <p data-bbox="1043 1677 1238 1727">Instruction code: 3AXD50000345632</p>

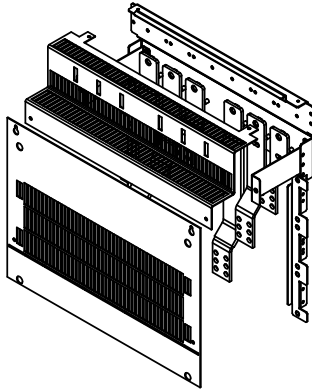
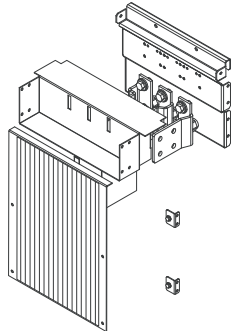
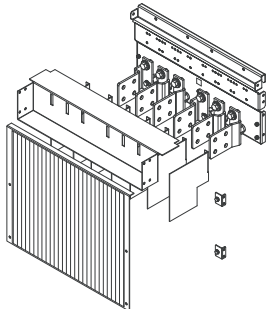
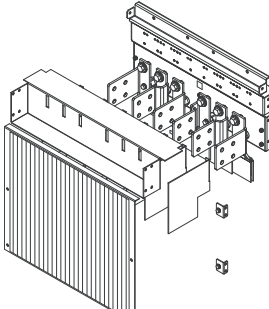
Used with...	Qty	Ordering code	Kit code	Illustration
600 mm VX25 enclosure (common AC output busbar connection)	1	3AXD50000337552	A-6-8-141-VX	 <p data-bbox="1193 707 1390 757">Instruction code: 3AXD50000346196</p>
400 mm generic enclosure (cable connection)	1	3AXD50000006435	A-4-8-135	 <p data-bbox="1193 1151 1390 1200">Instruction code: 3AXD50000006497</p>
600 mm generic enclosure (cable connection)	1	3AXD50000006491	A-6-8-136	 <p data-bbox="1193 1574 1390 1624">Instruction code: 3AXD50000006489</p>
600 mm generic enclosure (cable connection with bridging busbars)	1	3AXD50000006493	A-6-8-138	 <p data-bbox="1193 1998 1390 2047">Instruction code: 3AXD50000006505</p>

338 Ordering information

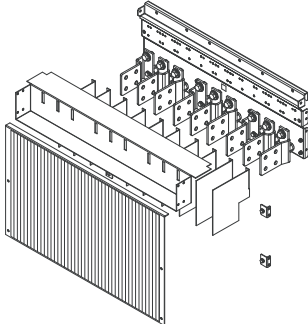
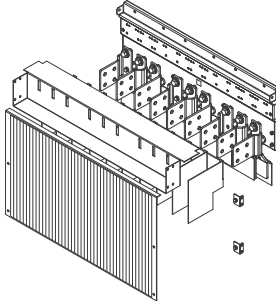
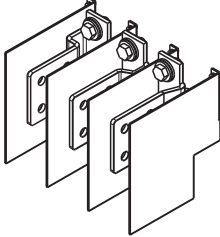
Used with...	Qty	Ordering code	Kit code	Illustration
800 mm generic enclosure (cable connection)	1	3AXD50000006492	A-8-8-137	 <p data-bbox="1042 647 1241 696">Instruction code: 3AXD50000006503</p>
800 mm generic enclosure (cable connection with bridging busbars)	1	3AXD50000006494	A-8-8-139	 <p data-bbox="1042 1066 1241 1115">Instruction code: 3AXD50000006498</p>
Generic enclosure (AC out- put busbars)	1 per mod- ule	3AXD50000008761	A-0-8-047	 <p data-bbox="1042 1435 1241 1485">Instruction code: 3AXD50000010859</p>

Cable entry kit

Cable entry kit, to be installed on the bottom plate of the enclosure, contains four 60 mm diameter inlets for cables with grommets, wire meshing for 360° grounding, and a strain relief bracket.

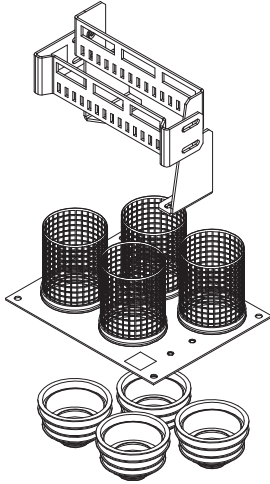
Used with ...	Qty	Ordering code	Kit code	Illustration
All enclosure types	1 per module (minimum)	3AXD50000004385	A-468-8-441	 <p>Instruction code: 3AXD50000004817</p>

■ Mechanical installation accessories

These kits include parts that are used for installing the inverter module in the enclosure.

Inverter module top/bottom guides

This kit contains the rails that guide the inverter module at the top and the bottom.

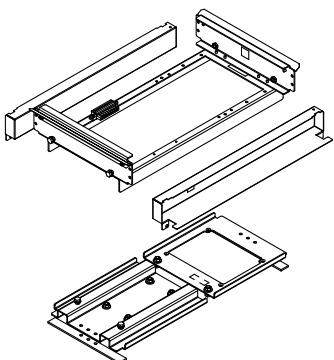
Used with ...	Qty	Ordering code	Kit code	Illustration
400 mm Rittal VX25 enclosure	1	3AXD50000337071	A-4-8-310-VX	 <p>Instruction code: 3AXD50000335152</p>

340 Ordering information

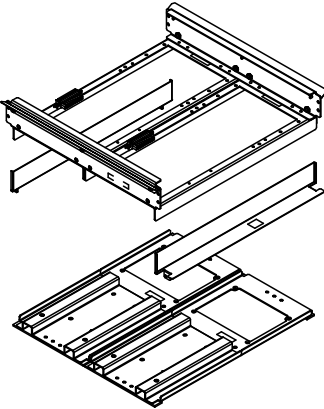
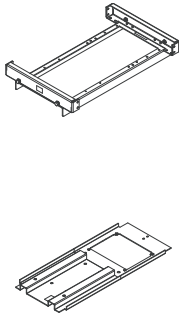
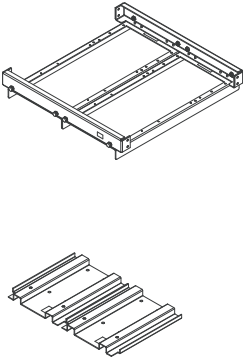
Used with ...	Qty	Ordering code	Kit code	Illustration
600 mm Rittal VX25 enclosure	1	3AXD50000337514	A-4-8-309-VX	 <p data-bbox="1034 725 1232 775">Instruction code: 3AXD50000345052</p>
400 mm generic enclosure	1	3AXD50000005875	A-4-8-315	 <p data-bbox="1034 1151 1232 1200">Instruction code: 3AXD50000005874</p>
600 mm generic enclosure	1	3AXD50000005876	A-6-8-311	 <p data-bbox="1034 1621 1232 1671">Instruction code: 3AXD50000005864</p>

Used with ...	Qty	Ordering code	Kit code	Illustration
800 mm generic enclosure	1	3AXD50000005877	A-8-8-312	 <p>Instruction code: 3AXD50000005848</p>

Insertion/Extraction ramp

The ramp can be used when inserting or extracting wheeled modules.

Do not use the ramp with plinth heights over 100 mm (3.93 in). The ramp is designed for a plinth height of 100 mm (the standard plinth height of Rittal VX25 enclosures).

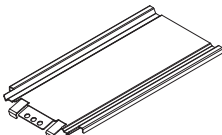
Used with ...	Qty	Ordering code	Kit code	Illustration
All VX25 enclosures	1	3AXD50000438037	A-468-8-304-VX	

Shrouding

This kit contains the shroud for the top part of the cubicle with the necessary brackets and screws.

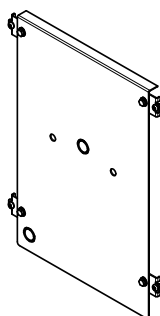
Used with ...	Qty	Ordering code	Kit code	Illustration
400 mm Rittal VX25 enclosure	1	3AXD50000331484	A-4-8-359-VX	 <p>Instruction code: 3AXD50000335169</p>

342 Ordering information

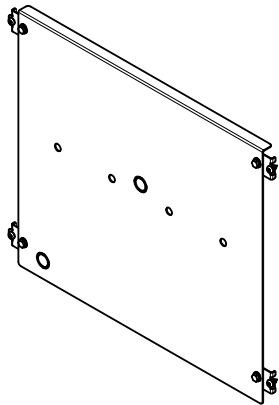
Used with ...	Qty	Ordering code	Kit code	Illustration
600 mm Rittal VX25 enclosure	1	3AXD50000337378	A-6-8-360-VX	 <p>Instruction code: 3AXD50000335022</p>

■ BLHF filters

Filter modules

Filter module	Ordering code
ACS880-BLHF-21-7+C188+V112	3AXD50000987191
ACS880-BLHF-21-7+C188+G427+V112	3AXD50000987207
ACS880-BLHF-22-7+C188+V112	3AXD50000987214
ACS880-BLHF-22-7+C188+G427+V112	3AXD50000987221

Control circuit plug connectors

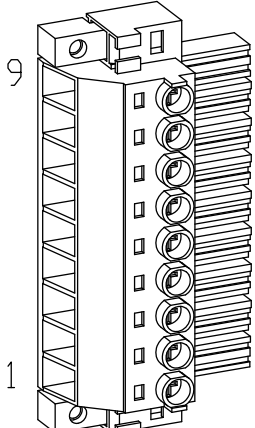
Connector	Data	Qty	Ordering code	Illustration
X30 for BLHF filters with +V112	BVZ 7.62HP/09/180FC SN BK BX LRP 9-pole (female) 10 mm ² , 1000 V, 57 A (UL/CSA: 600 V, 40.5 A)	1 per filter module	3AXD50000960248	

Filter module top/bottom guides

This kit contains the rails that guide the filter module at the top and the bottom.

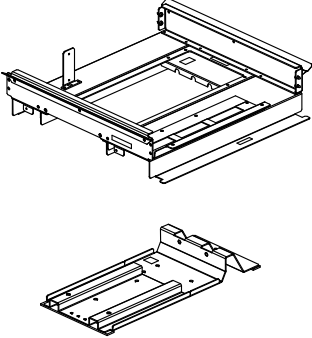
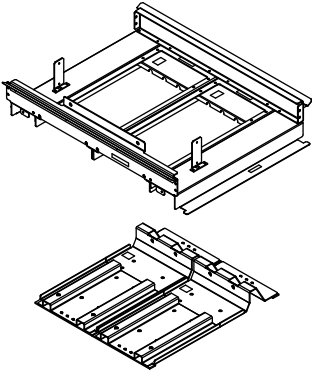
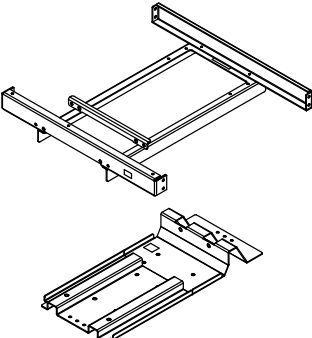
Used with ...	Qty	Ordering code	Kit code	Illustration
600 mm Rittal VX25 enclosure	1	3AXD50000883080	A-6-8-335-VX	 <p>Instruction code: 3AXD50000883684</p>
800 mm Rittal VX25 enclosure	1	3AXD50000883233	A-8-8-336-VX	 <p>Instruction code: 3AXD50000887408</p>
600 mm generic enclosure	1	3AXD50000883288	A-6-8-337	 <p>Instruction code: 3AXD50000887224</p>

344 Ordering information

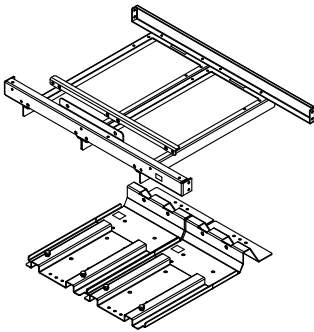
Used with ...	Qty	Ordering code	Kit code	Illustration
800 mm generic enclosure	1	3AXD50000883318	A-8-8-338	 <p>Instruction code: 3AXD50000887071</p>

AC connection parts

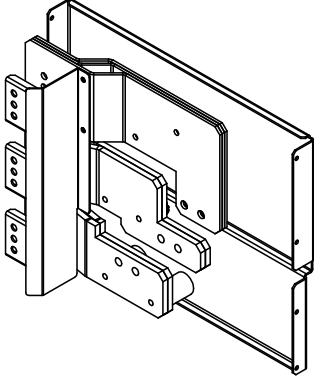
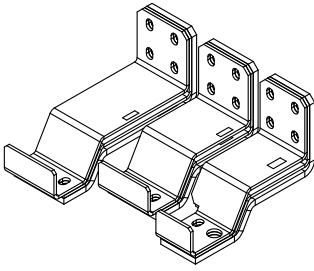
Used with...	Qty	Ordering code	Kit code	Illustration
600 mm Rittal VX25 enclosure (AC input bus-bars)	1	3AXD50000885053	A-6-8-118-VX	 <p>Instruction code: 3AXD50000887347</p>
600 mm Rittal VX25 or generic enclosure (AC flanges)	1	3AXD50000883219	A-X-8-149	 <p>Instruction code: 3AXD50000884216</p>

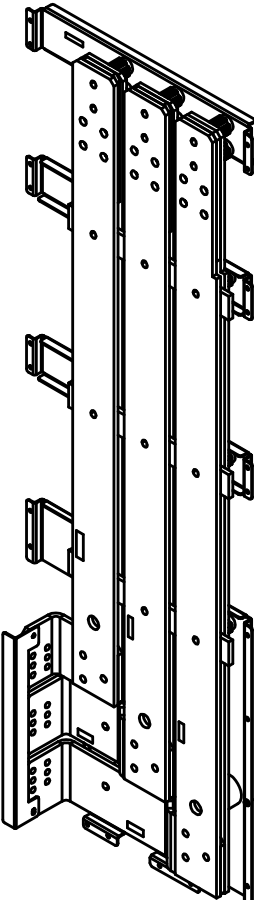
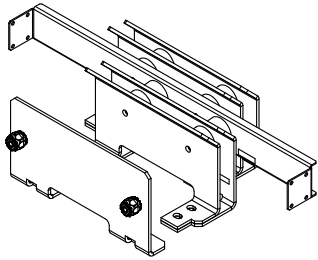
Used with...	Qty	Ordering code	Kit code	Illustration
600 mm Rittal VX25 enclosure (AC busbars)	1	3AXD50000883103	A-6-8-112-VX	 <p>Instruction code: 3AXD50000887231</p>
800 mm Rittal VX25 enclosure (AC connection busbars)	1	3AXD50000883264	A-8-8-116-VX	 <p>Instruction code: 3AXD50000887576</p>

346 Ordering information

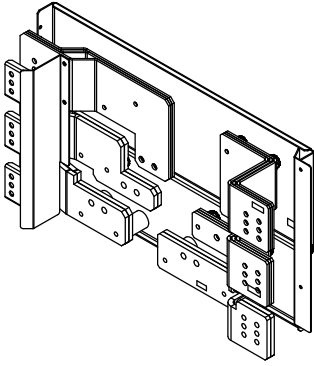
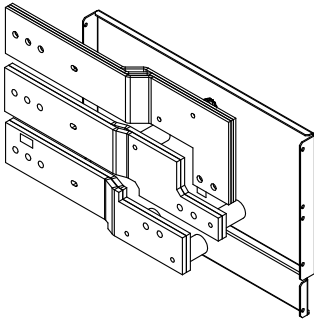
Used with...	Qty	Ordering code	Kit code	Illustration
800 mm Rittal VX25 enclosure (AC busbars)	1	3AXD50000883257	A-8-8-113-VX	 <p data-bbox="1034 680 1230 730">Instruction code: 3AXD50000887569</p>
600 mm generic enclosure (AC input busbars)	1	3AXD50000885060	A-6-8-119	 <p data-bbox="1034 1106 1230 1155">Instruction code: 3AXD50000887323</p>

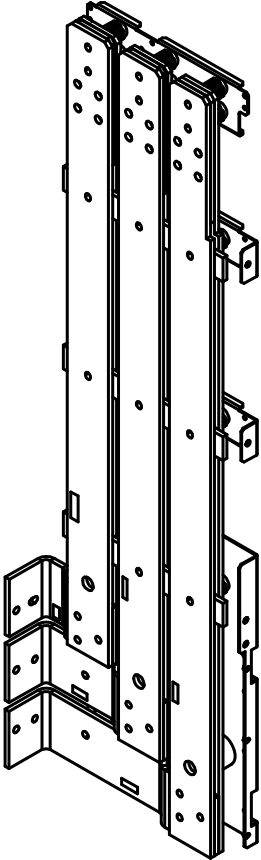
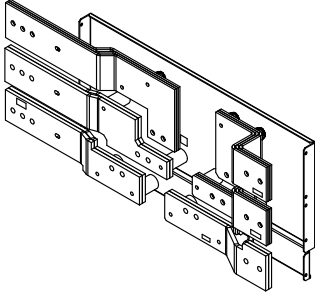
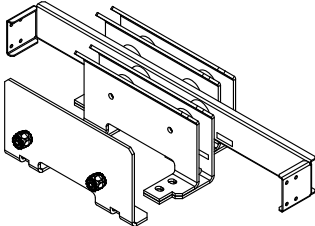
Used with...	Qty	Ordering code	Kit code	Illustration
600 mm generic enclosure (AC busbars)	1	3AXD50000883295	A-6-8-114	 <p data-bbox="1187 1184 1382 1234">Instruction code: 3AXD50000887330</p>
800 mm generic enclosure (AC busbars)	1	3AXD50000883332	A-8-8-115	 <p data-bbox="1187 1592 1382 1641">Instruction code: 3AXD50000887316</p>
800 mm generic enclosure (AC connection busbars)	1	3AXD50000883349	A-8-8-117	 <p data-bbox="1187 1928 1382 1977">Instruction code: 3AXD50000887088</p>

Shrouding

This kit contains the shroud with the necessary brackets and screws.

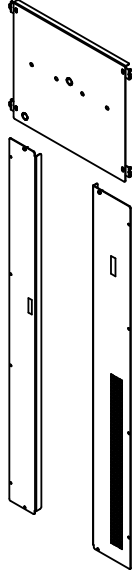
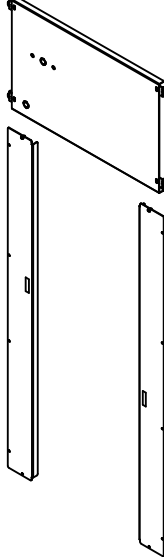
Used with ...	Qty	Ordering code	Kit code	Illustration
600 mm Rittal VX25 enclosure	1	3AXD50000883226	A-6-8-362-VX	 <p data-bbox="1050 1010 1249 1055">Instruction code: 3AXD50000887286</p>
800 mm Rittal VX25 enclosure	1	3AXD50000883271	A-8-8-363-VX	 <p data-bbox="1050 1682 1249 1727">Instruction code: 3AXD50000888016</p>

Cabinet ventilation

■ Air inlet kits

Air inlet kits 400 mm cabinet

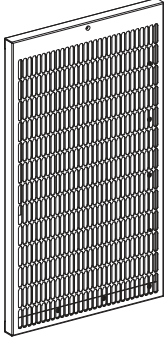
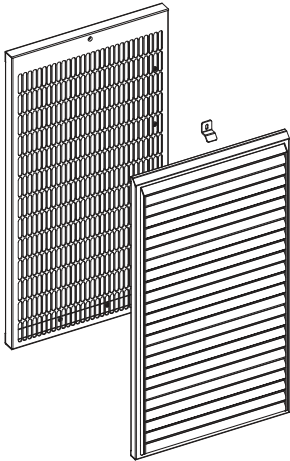
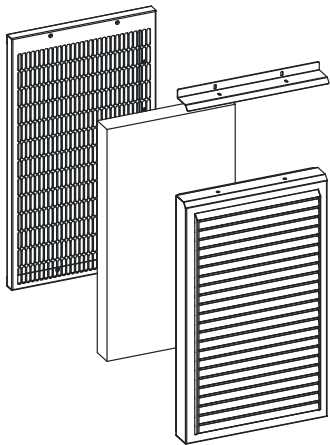
Used with ...	Qty	Ordering code	Kit code	Illustration
IP20	1	3AUA0000117002	A-4-X-021	 <p>Instruction code: 3AUA0000116879</p>
IP42	1	3AUA0000117007	A-4-X-024	 <p>Instruction code: 3AUA0000116873</p>
IP54	1	3AXD50000009184	A-4-X-027	 <p>Instruction code: 3AXD50000009989</p>

Air inlet kits 600 mm cabinet

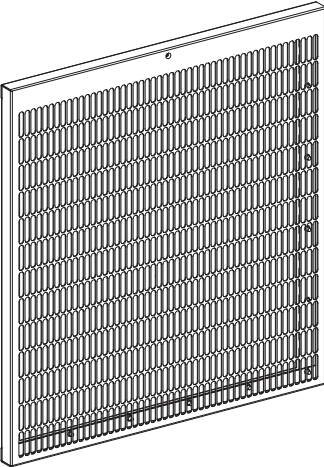
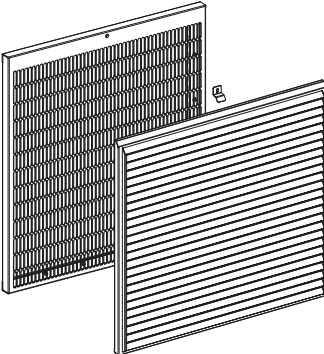
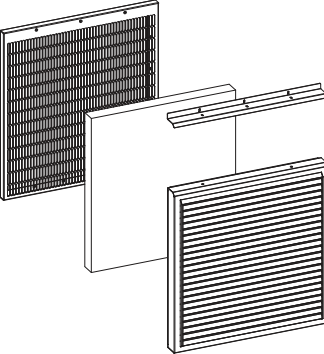
Used with ...	Qty	Ordering code	Kit code	Illustration
IP20	1	3AUA0000117003	A-6-X-022	 <p data-bbox="1043 831 1222 882">Instruction code: 3AUA0000116880</p>
IP42	1	3AUA0000117008	A-6-X-025	 <p data-bbox="1043 1279 1222 1330">Instruction code: 3AUA0000116874</p>
IP54	1	3AXD50000009185	A-6-X-028	 <p data-bbox="1043 1727 1222 1778">Instruction code: 3AXD50000009990</p>

Air inlet kits 800 mm cabinet

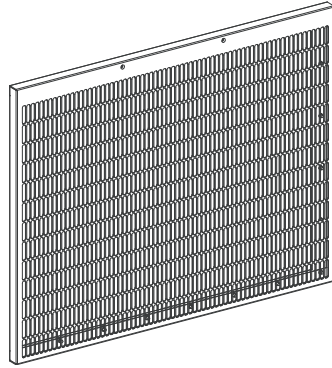
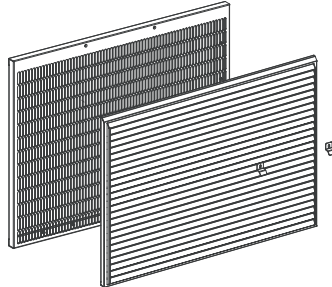
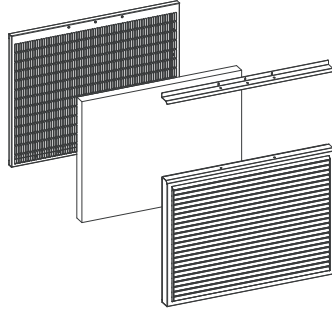
Used with ...	Qty	Ordering code	Kit code	Illustration
IP20	1	3AUA0000117005	A-8-X-023	 <p>Instruction code: 3AUA0000116887</p>
IP42	1	3AUA0000117009	A-8-X-026	 <p>Instruction code: 3AUA0000116875</p>
IP54	1	3AXD50000009186	A-8-X-029	 <p>Instruction code: 3AXD50000010001</p>

- **Air outlet kits**

Air outlet kits 400 mm cabinet

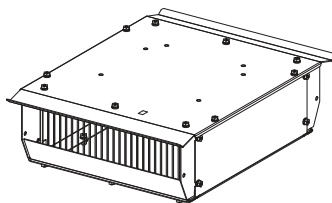
Used with ...	Qty	Ordering code	Kit code	Illustration
IP20	1	3AUA0000125203	A-4-X-042	 <p>Instruction code: 3AXD50000001983</p>

352 Ordering information

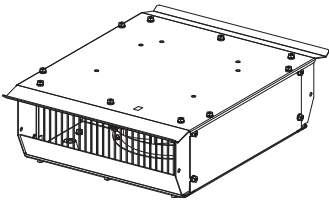
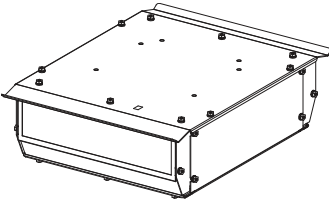
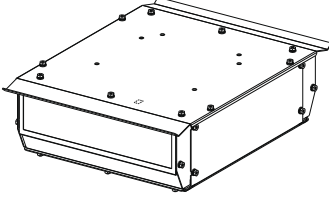
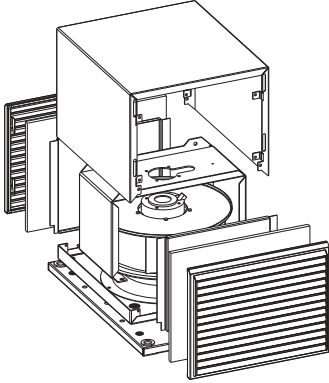
Used with ...	Qty	Ordering code	Kit code	Illustration
IP20	1	3AUA0000125201 Note: Plug connectors are included.	A-4-X-062	 <p>Instruction code: 3AXD50000001982</p> <p>Note: Fan to be ordered separately</p>
IP42	1	3AUA0000114968	A-4-X-040	 <p>Instruction code: 3AUA0000115292</p>
IP42	1	3AUA0000114967 Note: Plug connectors are included.	A-4-X-060	 <p>Instruction code: 3AUA0000115290</p> <p>Note: Fan to be ordered separately</p>
IP54 (230 V)	1	3AXD50000009187 Note: Wire harness and plug connector are included.	A-4-X-064	 <p>Instruction code: 3AXD50000010284</p> <p>Note: Fan to be ordered separately</p>

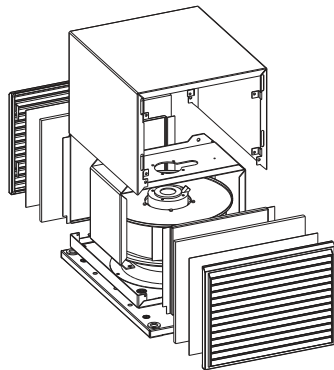
Used with ...	Qty	Ordering code	Kit code	Illustration
IP54 (115 V)	1	3AXD50000010362 Note: Wire harness and plug connector are included.	A-4-X-067	 <p>Instruction code: 3AXD50000010284</p> <p>Note: Fan to be ordered separately</p>

Air outlet kits 600 mm cabinet

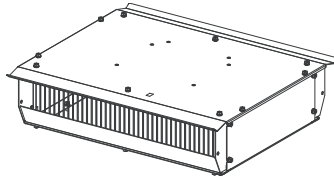
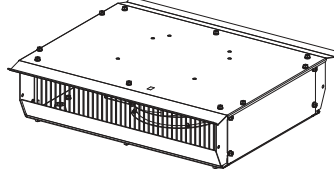
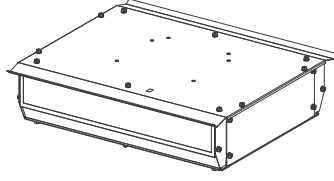
Used with ...	Qty	Ordering code	Kit code	Illustration
IP20	1	3AUA0000125204	A-6-X-043	 <p>Instruction code: 3AXD50000001981</p>
IP20	1	3AUA0000125202 Note: Plug connectors are included.	A-6-X-063	 <p>Instruction code: 3AXD50000001980</p> <p>Note: Fan to be ordered separately</p>
IP42	1	3AUA0000114789	A-6-X-041	 <p>Instruction code: 3AUA0000115166</p>

354 Ordering information

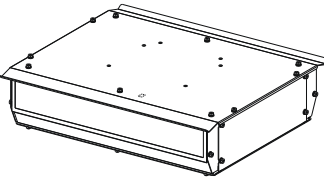
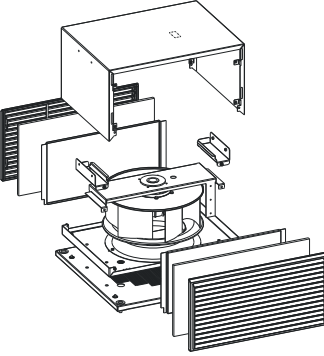
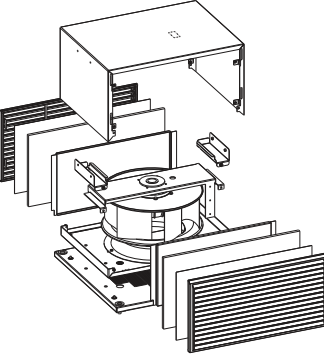
Used with ...	Qty	Ordering code	Kit code	Illustration
IP42	1	3AUA0000114971 Note: Plug connectors are included.	A-6-X-061	 <p>Instruction code: 3AUA0000115152</p> <p>Note: Fan to be ordered separately</p>
IP54 (IEC)	1	3AXD5000009189 Note: Wire harness and plug connector are included.	A-6-X-065	 <p>Instruction code: 3AXD5000010004</p> <p>Note: Fan to be ordered separately</p>
IP54 (UL)	1	3AXD5000010327 Note: Wire harness and plug connector are included.	A-6-X-066	 <p>Instruction code: 3AXD5000010004</p> <p>Note: Fan to be ordered separately</p>

Air outlet kits 800 mm cabinet

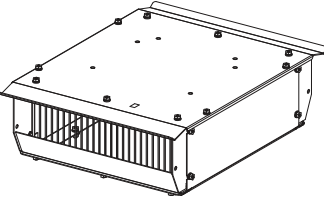
Used with ...	Qty	Ordering code	Kit code	Illustration
IP20	2	3AUA0000125203	A-4-X-042	 <p>Instruction code: 3AXD5000001983</p>

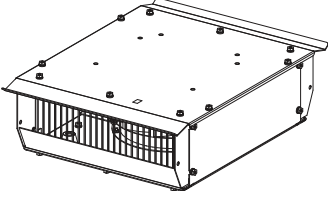
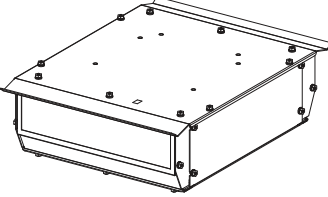
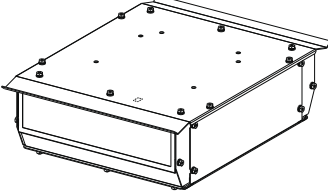
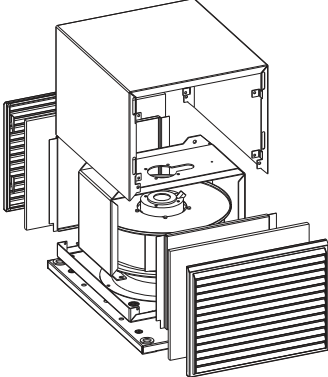
Used with ...	Qty	Ordering code	Kit code	Illustration
IP20	2	3AUA0000125201 Note: Plug connectors are included.	A-4-X-062	 <p>Instruction code: 3AXD50000001982</p> <p>Note: Fan to be ordered separately</p>
IP42	2	3AUA0000114968	A-4-X-040	 <p>Instruction code: 3AUA0000115292</p>
IP42	2	3AUA0000114967 Note: Plug connectors are included.	A-4-X-060	 <p>Instruction code: 3AUA0000115290</p> <p>Note: Fan to be ordered separately</p>
IP54 (230 V)	2	3AXD50000009187 Note: Wire harness and plug connector are included.	A-4-X-064	 <p>Instruction code: 3AXD50000010284</p> <p>Note: Fan to be ordered separately</p>

356 Ordering information

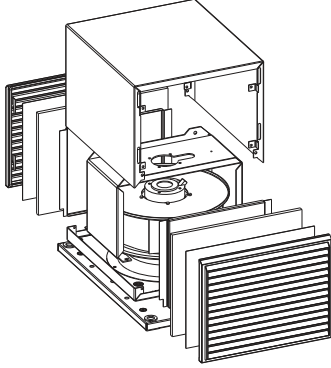
Used with ...	Qty	Ordering code	Kit code	Illustration
IP54 (115 V)	2	3AXD50000010362 Note: Wire harness and plug connector are included.	A-4-X-067	 <p data-bbox="1034 667 1230 719">Instruction code: 3AXD50000010284</p> <p data-bbox="970 734 1299 792">Note: Fan to be ordered separately</p>

■ Cooling fans (frames R1i...R4i)

One or two cooling fans are to be installed inside the air outlet compartment to ensure sufficient cooling of the cabinet.

IEC				
Enclosure width / Degree of protection (Auxiliary voltage)	Component		Qty	Ordering code
	Name	Data		
400 mm, 600 mm / IP20, IP42 (230 V 50/60 Hz)	Fan	0.77 A; 230 V; 96 W; 50/60 Hz	1	3AXD50000000592
400 mm / IP54 (230 V 50/60 Hz)	Fan	1.1 A; 230 V; 240 W; 50 Hz 1.45 A; 230 V; 350 W; 60 Hz	1	3AXD50000006934
	Capacitor	6 µF, 600 V	1	3AXD50000006959
600 mm / IP54 (230 V 50/60 Hz)	Fan	2.3 A; 230 V; 540 W; 50 Hz 3 A; 230 V; 690 W; 60 Hz	1	3AXD50000006111
	Capacitor	12 µF, 600 V	1	3AXD50000006885
800 mm / IP20, IP42 (230 V 50/60 Hz)	Fan	0.77 A; 230 V; 96 W; 50/60 Hz	2	3AXD50000000592
800 mm / IP54 (230 V 50/60 Hz)	Fan	1.1 A; 230 V; 240 W; 50 Hz 1.45 A; 230 V; 350 W; 60 Hz	2	3AXD50000006934
	Capacitor	6 µF, 600 V	2	3AXD50000006959

UL				
Enclosure width / Degree of protection (Auxiliary voltage)	Component		Qty	Ordering code
	Name	Data		
400 mm, 600 mm / IP20, IP42 (230 V 50/60 Hz)	Fan	0.77 A; 230 V; 96 W; 50/60 Hz	1	3AXD50000000592
400 mm, 600 mm / IP20, IP42 (115 V 60 Hz)	Fan	115 V; 115 W; 50/60 Hz	1	3AXD50000700288
400 mm / IP54 (230 V 50/60 Hz)	Fan	1.1 A; 230 V; 240 W; 50 Hz 1.45 A; 230 V; 350 W; 60 Hz	1	3AXD50000006934
	Capacitor	6 µF, 600 V	1	3AXD50000006959
400 mm / IP54 (115 V 50/60 Hz)	Fan	3.1 A; 115 V; 300 W; 50 Hz 3.9 A; 115 V; 430 W; 60 Hz	1	64750062
	Capacitor	25 µF, 220 V	1	68713188
600 mm / IP54 (230 V 50/60 Hz)	Fan	2.3 A; 230 V; 540 W; 50 Hz 3 A; 230 V; 690 W; 60 Hz	1	3AXD50000006111
	Capacitor	12 µF, 600 V	1	3AXD50000006885
600 mm / IP54 (115 V 50/60 Hz)	Fan	6.3 A; 115 V; 680 W; 60 Hz	1	64750038
	Capacitor	25 µF, 220 V	1	68713188
800 mm / IP20, IP42 (230 V 50/60 Hz)	Fan	0.77 A; 230 V; 96 W; 50/60 Hz	2	3AXD50000000592
800 mm / IP20, IP42 (115 V 60 Hz)	Fan	115 V; 115 W; 50/60 Hz	2	3AXD50000700288

UL				
Enclosure width / Degree of protection (Auxiliary voltage)	Component		Qty	Ordering code
	Name	Data		
800 mm / IP54 (230 V 50/60 Hz)	Fan	1.1 A; 230 V; 240 W; 50 Hz 1.45 A; 230 V; 350 W; 60 Hz	2	3AXD50000006934
	Capacitor	6 µF, 600 V	2	3AXD50000006959
800 mm / IP54 (115 V 50/60 Hz)	Fan	3.1 A; 115 V; 300 W; 50 Hz 3.9 A; 115 V; 430 W; 60 Hz	2	64750062
	Capacitor	25 µF, 220 V	2	68713188

Fan wire sets for cooling fans

Item	Pcs/module	Ordering code
Fan wire set for ZCU-12	1	3AXD50000003308

The wiring diagram examples show a cabinet cooling fan circuit that energizes the fan when at least one inverter module installed in the cabinet is running. The fan will continue to operate for 20 minutes after all inverter modules have been stopped.

The following parts (or equivalent) are used to implement the circuit. These parts are to be sourced by the customer.

- Phoenix Contact ST 2,5-DIO/L-R - 3036262 spring cage component terminal block with a 1N4007 diode
- Relpol PI84-24DC-M41G relay
 - Rated load (capacity): 8 A / 24 V DC
 - Rated power consumption: 0.40 ... 0.48 W DC
 - GZT80 relay socket
- 600 mm of AWG24, 300 V, UL1569 (or equivalent material, valid for PVC insulation only) wire
- Favier SEP-4 light brown 4 kV fiberglass sleeving

■ Cooling fans (frames R5i)

A cooling fan is to be installed inside the air outlet compartment to ensure sufficient cooling of the cabinet.

IEC				
Enclosure width / Degree of protection (Auxiliary voltage)	Component		Qty	Ordering code
	Name	Data		
400 mm, 600 mm / IP20, IP42 (230 V 50/60 Hz)	Fan	0.77 A; 230 V; 96 W; 50/60 Hz	1	3AXD50000000592
400 mm / IP54 (230 V 50/60 Hz)	Fan	1.1 A; 230 V; 240 W; 50 Hz 1.45 A; 230 V; 350 W; 60 Hz	1	3AXD50000006934
	Capacitor	6 μ F, 600 V	1	3AXD50000006959
600 mm / IP54 (230 V 50/60 Hz)	Fan	2.3 A; 230 V; 540 W; 50 Hz 3 A; 230 V; 690 W; 60 Hz	1	3AXD50000006111
	Capacitor	12 μ F, 600 V	1	3AXD50000006885

UL				
Enclosure width / Degree of protection (Auxiliary voltage)	Component		Qty	Ordering code
	Name	Data		
400 mm, 600 mm / IP20, IP42 (230 V 50/60 Hz)	Fan	0.77 A; 230 V; 96 W; 50/60 Hz	1	3AXD50000000592
400 mm, 600 mm / IP20, IP42 (115 V 60 Hz)	Fan	R3G225-RE19-32	1	3AXD50000700288
400 mm / IP54 (230 V 50/60 Hz)	Fan	1.1 A; 230 V; 240 W; 50 Hz 1.45 A; 230 V; 350 W; 60 Hz	1	3AXD50000006934
	Capacitor	6 μ F, 600 V	1	3AXD50000006959
400 mm / IP54 (115 V 50/60 Hz)	Fan	3.1 A; 115 V; 300 W; 50 Hz 3.9 A; 115 V; 430 W; 60 Hz	1	64750062
	Capacitor	25 μ F, 220 V	1	68713188
600 mm / IP54 (230 V 50/60 Hz)	Fan	2.3 A; 230 V; 540 W; 50 Hz 3 A; 230 V; 690 W; 60 Hz	1	3AXD50000006111
	Capacitor	12 μ F, 600 V	1	3AXD50000006885
600 mm / IP54 (115 V 50/60 Hz)	Fan	6.3 A; 115 V; 680 W; 60 Hz	1	64750038
	Capacitor	25 μ F, 220 V	1	68713188

Fan wire sets for cooling fans

The wiring diagram examples show a cabinet cooling fan circuit that energizes the fan when at least one inverter module installed in the cabinet is running. The fan will continue to run for 20 minutes after all inverter modules have been stopped.

Item	Pcs/module	Ordering code
Fan wire set for ZCU-12 or ZCU-14	1	3AXD50000003308

360 Ordering information

The following parts (or equivalent) are used to implement the circuit. These parts are to be sourced by the customer.

- Phoenix Contact ST 2,5-DIO/L-R - 3036262 spring cage component terminal block with a 1N4007 diode
- Relpol PI84-24DC-M41G relay
 - Rated load (capacity): 8 A / 24 V DC
 - Rated power consumption: 0.40 ... 0.48 W DC
 - GZT80 relay socket
- 600 mm of AWG24, 300 V, UL1569 (or equivalent material, valid for PVC insulation only) wire
- Favier SEP-4 light brown 4 kV fiberglass sleeving

■ Cooling fans (frames R6i...R7i)

A cooling fan is to be installed inside the IP54 air outlet compartment to ensure sufficient cooling of the cabinet.

Enclosure width / Degree of protection (Auxiliary voltage)	Component		Qty	Ordering code
	Name	Data		
400 mm / IP54 (230 V 50/60 Hz)	Fan	1.1 A; 230 V; 240 W; 50 Hz 1.45 A; 230 V; 350 W; 60 Hz	1	3AXD50000006934
	Capacitor	6 µF, 600 V	1	3AXD50000006959
400 mm / IP54 (115 V 50/60 Hz)	Fan	3.1 A; 115 V; 300 W; 50 Hz 3.9 A; 115 V; 430 W; 60 Hz	1	64750062
	Capacitor	25µF, 220 V	1	68713188

■ Cooling fans (frames R8i)

Cooling fans

One or two cooling fans are to be installed inside the air outlet compartment to ensure sufficient cooling of the cabinet.

IEC/UL				
Enclosure / Degree of protection (Auxiliary voltage)	Component		Qty	Ordering code
	Name	Data		
400 mm / IP54 (230 V, 50/60 Hz)	Fan	1.1 A; 230 V; 240 W; 50 Hz 1.45 A; 230 V; 350 W; 60 Hz	1	3AXD50000006934
	Capacitor	6 μ F, 600 V	1	3AXD50000006959
600 mm / IP54 (230 V, 50/60 Hz)	Fan	2.3 A; 230 V; 540 W; 50 Hz 3 A; 230 V; 690 W; 60 Hz	1	3AXD50000006111
	Capacitor	12 μ F, 600 V	1	3AXD50000006885
800 mm / IP54 (230 V, 50/60 Hz)	Fan	1.1 A; 230 V; 240 W; 50 Hz 1.45 A; 230 V; 350 W; 60 Hz	2	3AXD50000006934
	Capacitor	6 μ F, 600 V	2	3AXD50000006959

UL/CSA				
Enclosure / Degree of protection (Auxiliary voltage)	Component		Qty	Ordering code
	Name	Data		
400 mm / IP54 (115 V, 50/60 Hz)	Fan	3.1 A; 115 V; 300 W; 50 Hz 3.9 A; 115 V; 430 W; 60 Hz	1	64750062
	Capacitor	25 μ F; 220 V	1	68713188
600 mm / IP54 (115 V, 50/60 Hz)	Fan	6.3 A; 115 V; 680 W; 60 Hz	1	64750038
	Capacitor	25 μ F; 220 V	1	68713188
800 mm / IP54 (115 V, 50/60 Hz)	Fan	3.1 A; 115 V; 300 W; 50 Hz 3.9 A; 115 V; 430 W; 60 Hz	2	64750062
	Capacitor	25 μ F, 220 V	2	68713188

12

Technical data

Contents of this chapter

This chapter contains the technical specifications of the inverter modules and associated components.

Ratings

ACS880-104- ...	Frame size	Input ratings	Output ratings							
			No-overload use				Light-overload use		Heavy-duty use	
			I_1	I_{max}	I_2	P_n	S_n	I_{Ld}	P_{Ld}	I_{Hd}
A	A	A	kW	kVA	A	kW	A	kW		
$U_n = 400\text{ V}$										
004A8-3	R1i	5.8	7.0	4.8	1.5	3.3	4.5	1.5	4.0	1.5
006A0-3	R1i	7.2	8.8	6.0	2.2	4.2	5.5	2.2	5.0	1.5
008A0-3	R1i	9.6	10.5	8.0	3.0	5.5	7.6	3.0	6.0	2.2
0011A-3	R2i	12.6	13.5	10.5	4.0	7.3	9.7	4.0	9.0	3.0
0014A-3	R2i	16.8	16.5	14.0	5.5	9.7	13.0	5.5	11.0	4.0
0018A-3	R2i	21.6	21	18.0	7.5	12.5	16.8	7.5	14.0	5.5
0025A-3	R3i	30	33	25	11.0	17.0	23	11.0	19.0	7.5
0035A-3	R3i	42	44	35	15.0	24	32	15.0	29	11.0
0044A-3	R3i	53	53	44	18.5	30	41	18.5	35	15.0
0050A-3	R3i	60	66	50	22	35	46	22	44	22
0061A-3	R4i	73	78	61	30	42	57	30	52	22
0078A-3	R4i	94	100	78	37	54	74	37	69	30
0094A-3	R4i	113	124	94	45	65	90	45	75	37

364 Technical data

ACS880-104- ...	Frame size	Input ratings		Output ratings						
				No-overload use			Light-overload use		Heavy-duty use	
		I_1	I_{max}	I_2	P_n	S_n	I_{Ld}	P_{Ld}	I_{Hd}	P_{Hd}
		A	A	A	kW	kVA	A	kW	A	kW
0100A-3	R4i	125	125	104	55	72	100	55	78	37
0140A-3	R6i	169	183	141	75	98	135	75	105	55
0170A-3	R6i	203	220	169	90	117	162	90	126	55
0210A-3	R6i	247	268	206	110	143	198	110	154	75
0250A-3	R6i	295	320	246	132	170	236	132	184	90
0300A-3	R7i	360	390	300	160	208	288	160	224	110
0350A-3	R7i	420	455	350	200	242	336	160	262	132
0470A-3	R8i	529	620	470	250	326	451	250	352	160
0640A-3	R8i	720	840	640	355	443	614	315	479	250
0760A-3	R8i	855	990	760	400	527	730	400	568	315
0830A-3	R8i	934	1080	830	450	575	797	400	621	315
0900A-3	R8i	1013	1080	900	500	624	864	450	673	355
1250A-3	2×R8i	1406	1630	1250	630	866	1200	630	935	500
1480A-3	2×R8i	1665	1930	1480	800	1025	1421	800	1107	630
1760A-3	2×R8i	1980	2120	1760	1000	1219	1690	900	1316	710
2210A-3	3×R8i	2486	2880	2210	1200	1531	2122	1200	1653	900
2610A-3	3×R8i	2936	3140	2610	1400	1808	2506	1400	1952	1000
3450A-3	4×R8i	3881	4140	3450	1800	2390	3312	1800	2581	1400
4290A-3	5×R8i	4826	5150	4290	2400	2972	4118	2000	3209	1800
5130A-3	6×R8i	5771	6160	5130	2800	3554	4925	2400	3837	2000
$U_n = 500\text{ V}$										
003A6-5	R1i	4.3	5.3	3.6	1.5	3.1	3.4	1.5	3.0	1.5
004A8-5	R1i	5.8	7.0	4.8	2.2	4.2	4.5	2.2	4.0	1.5
006A0-5	R1i	7.2	8.8	6.0	3.0	5.2	5.5	3.0	5.0	2.2
008A0-5	R1i	9.6	10.5	8.0	4.0	6.9	7.6	4.0	6.0	3.0
0011A-5	R2i	12.6	13.5	10.5	5.5	9.1	9.7	5.5	9.0	4.0
0014A-5	R2i	16.8	16.5	14.0	7.5	12.1	13.0	7.5	11.0	5.5
0018A-5	R2i	21.6	21	18.0	11.0	16	16.8	11.0	14.0	7.5
0025A-5	R3i	30	33	25	15.0	22	23	15.0	19.0	11.0
0030A-5	R3i	36	36	30	18.5	26	28	18.5	24	15.0
0035A-5	R3i	42	44	35	22	30	32	22	29	18.5
0050A-5	R3i	60	66	50	30	43	45	30	44	22
0061A-5	R4i	73	78	61	37	53	57	37	52	30
0078A-5	R4i	94	100	78	45	68	74	45	59	45
0094A-5	R4i	113	124	94	55	81	90	55	75	45
0110A-5	R6i	136	147	113	75	98	108	75	85	55
0140A-5	R6i	163	177	136	90	118	131	90	102	55
0170A-5	R6i	198	215	165	110	143	158	110	123	75

ACS880-104- ...	Frame size	Input ratings	Output ratings							
			No-overload use				Light-overload use		Heavy-duty use	
		I_1	I_{max}	I_2	P_n	S_n	I_{Ld}	P_{Ld}	I_{Hd}	P_{Hd}
		A	A	A	kW	kVA	A	kW	A	kW
0200A-5	R6i	236	256	197	132	171	189	132	147	90
0240A-5	R6i	288	312	240	160	208	230	160	180	110
0300A-5	R7i	362	393	302	200	262	290	200	226	132
0340A-5	R7i	408	442	340	250	294	326	200	254	160
0440A-5	R8i	495	580	440	250	381	422	250	329	200
0590A-5	R8i	664	770	590	400	511	566	355	441	250
0670A-5	R8i	754	880	670	450	580	643	400	501	315
0740A-5	R8i	833	970	740	500	641	710	450	554	355
0810A-5	R8i	911	1060	810	560	701	778	500	606	400
1150A-5	2×R8i	1294	1500	1150	800	996	1104	710	860	560
1450A-5	2×R8i	1631	1890	1450	1000	1256	1392	900	1085	710
1580A-5	2×R8i	1778	2060	1580	1100	1368	1517	1000	1182	800
2150A-5	3×R8i	2419	2800	2150	1500	1862	2064	1400	1608	1100
2350A-5	3×R8i	2644	3060	2350	1600	2035	2256	1500	1758	1200
3110A-5	4×R8i	3499	4050	3110	2000	2693	2986	2000	2326	1600
3860A-5	5×R8i	4343	5020	3860	2400	3343	3706	2400	2887	2000
4610A-5	6×R8i	5186	6000	4610	3200	3992	4426	2800	3448	2400
$U_n = 690 V$										
007A3-7	R5i	8.8	9.5	7.3	5.5	8.7	6.9	5.5	5.6	4.0
009A8-7	R5i	11.8	12.7	9.8	7.5	11.7	9.3	7.5	7.33	5.5
014A2-7	R5i	17.0	18.5	14.2	11.0	17.0	13.5	11.0	9.8	7.5
0018A-7	R5i	22	23	18.0	15.0	21.5	17.1	15.0	14.2	11.0
0022A-7	R5i	26	29	22	18.5	26	21	18.5	18.0	15.0
0027A-7	R5i	32	35	27	22	32	26	22	22	18.5
0035A-7	R5i	42	46	35	30	42	33	30	27	22
0042A-7	R5i	50	55	42	37	50	40	37	35	30
0052A-7	R5i	62	68	52	45	62	49	45	42	37
0062A-7	R6i	74	81	62	55	74	60	55	46	45
0082A-7	R6i	98	107	82	75	98	79	75	61	55
0100A-7	R6i	119	129	99	90	118	95	90	74	75
0130A-7	R6i	150	163	125	110	149	120	110	94	75
0140A-7	R6i	173	187	144	132	172	138	132	108	90
0190A-7	R6i	230	250	192	160	229	184	160	144	132
0220A-7	R7i	260	282	217	200	259	208	200	162	160
0270A-7	R7i	324	351	270	250	323	259	250	202	200
0340A-7	R8i	383	510	340	315	406	326	250	254	200
0410A-7	R8i	461	620	410	400	490	394	355	307	250
0480A-7	R8i	540	720	480	450	574	461	400	359	315

ACS880-104- ...	Frame size	Input ratings	Output ratings							
			No-overload use				Light-overload use		Heavy-duty use	
		I_1	I_{max}	I_2	P_n	S_n	I_{Ld}	P_{Ld}	I_{Hd}	P_{Hd}
		A	A	A	kW	kVA	A	kW	A	kW
0530A-7	R8i	596	800	530	500	633	509	450	396	355
0600A-7	R8i	675	900	600	560	717	576	560	449	400
0800A-7	2×R8i	900	1200	800	800	956	768	710	598	560
1030A-7	2×R8i	1159	1550	1030	1000	1231	989	900	770	710
1170A-7	2×R8i	1316	1760	1170	1100	1398	1123	1000	875	800
1540A-7	3×R8i	1733	2310	1540	1400	1840	1478	1400	1152	1100
1740A-7	3×R8i	1958	2610	1740	1600	2080	1670	1600	1302	1200
2300A-7	4×R8i	2588	3450	2300	2000	2749	2208	2000	1720	1600
2860A-7	5×R8i	3218	4290	2860	2800	3418	2746	2400	2139	2000
3420A-7	6×R8i	3848	5130	3420	3200	4087	3283	3200	2558	2400
3990A-7	7×R8i	4489	5990	3990	3600	4769	3830	3600	2985	2800
4560A-7	8×R8i	5130	6840	4560	4400	5450	4378	4000	3411	3200
5130A-7	9×R8i	5771	7700	5130	4800	6131	4925	4800	3837	3600
5700A-7	10×R8i	6413	8550	5700	5600	6812	5472	5200	4264	4000

■ Definitions

U_n	Nominal AC supply voltage of drive system
I_1	Nominal DC input current
I_2	Nominal output current (available continuously with no overloading)
I_{max}	Maximum output current. Available for 10 seconds at start; otherwise as long as allowed by drive temperature
P_n	Typical motor power in no-overload use
S_n	Apparent power in no-overload use
I_{Ld}	Continuous rms output current allowing 10% overload for 1 minute every 5 minutes
P_{Ld}	Typical motor power in light-overload use
I_{Hd}	Continuous rms output current allowing 50% overload for 1 minute every 5 minutes
P_{Hd}	Typical motor power in heavy-duty use

Note:

- The ratings apply at an ambient temperature of 40 °C (104 °F) or less and an altitude of 1000 m (3281 ft) or less.
 - The ratings apply to units without option +C132 (marine type approval). For ratings of units with option +C132, see [ACS880 +C132 marine type-approved drive modules and module packages supplement \(3AXD50000037752 \[English\]\)](#).
 - To achieve the rated motor power given in the table, the rated current of the drive must be higher than or equal to the rated motor current.
 - The DriveSize dimensioning tool available from ABB is recommended for selecting the drive, motor and gear combination.
-

Derating

■ Surrounding air temperature derating

In the temperature range +40...50 °C (+104...122 °F), the rated output current is derated by 1 percentage point for every added 1 °C (1.8 °F). The output current can be calculated by multiplying the current given in the rating table by the derating factor (*k*):

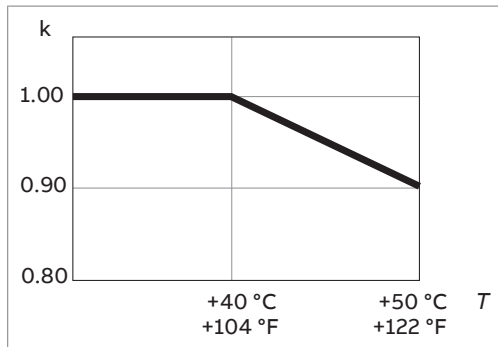



■ Altitude derating

At altitudes more than 1000 m (3281 ft) above sea level, the output current derating is 1 percentage point for every added 100 m (328 ft). For example, the derating factor for 1500 m (4921 ft) is 0.95. The maximum permitted installation altitude is given in the technical data.

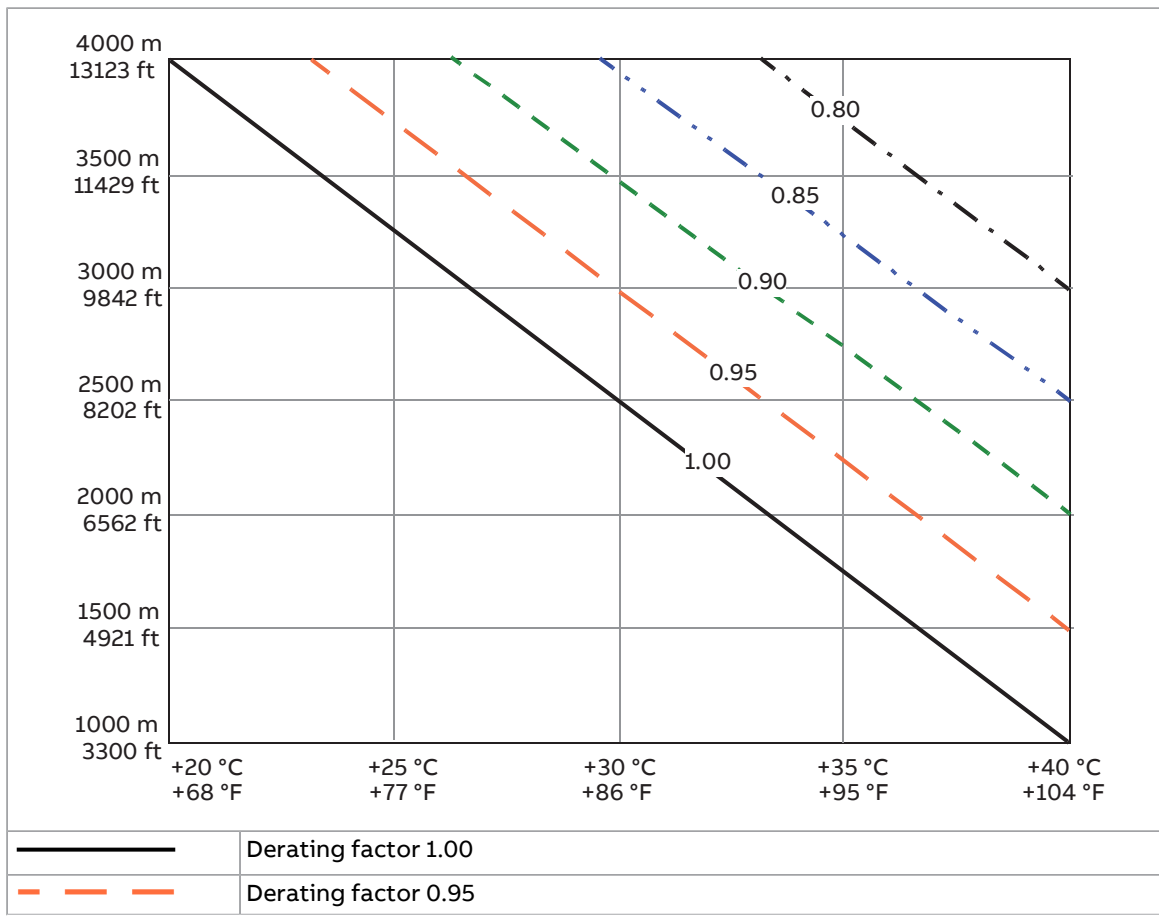
If the surrounding air temperature is less than +40 °C (104 °F), the derating can be reduced by 1.5 percentage points for every 1 °C (1.8 °F) reduction in temperature. A few altitude derating curves are shown below.



	Derating factor 0.90
	Derating factor 0.85
	Derating factor 0.80

For a more accurate derating, use the DriveSize PC tool.

■ Switching frequency derating

Switching frequencies other than default can require output current derating. Contact ABB for more information.

■ Output frequency derating

The rated output current needs type-specific derating in these conditions:

- the output frequency is continuously or frequently less than 12 Hz
- the output frequency is more than 150 Hz.

If the inverter is used temporarily at an output frequency of less than 12 Hz, it does not need to be derated.

Contact ABB for more information.

Cooling characteristics, noise, DC capacitance

ACS880-104-...	Power loss	Air flow		Noise ¹⁾	DC capacitance
	W	m ³ /h	ft ³ /min	dB (A)	mF
$U_n = 400 \text{ V}$					
004A8-3	70	24	14	47	0.280
006A0-3	80	24	14	47	0.280
008A0-3	90	24	14	47	0.280
0011A-3	110	48	28	39	0.435
0014A-3	140	48	28	39	0.865
0018A-3	170	48	28	39	0.865
0025A-3	200	142	84	63	0.785
0035A-3	300	142	84	63	0.785
0044A-3	350	200	118	71	1.178
0050A-3	410	200	118	71	1.178
0061A-3	500	290	171	70	1.570
0078A-3	600	290	171	70	2.355
0094A-3	740	290	171	70	2.355
0100A-3	750	290	171	70	2.355
0140A-3	1100	650	383	71	4.500
0170A-3	1400	650	383	71	4.500
0210A-3	1800	650	383	71	4.500
0250A-3	2000	650	383	71	6.750
0300A-3	2500	940	553	72	9.000
0350A-3	3100	940	553	72	9.000
0470A-3	4800	1300	765	72	11.250

370 Technical data

ACS880-104-...	Power loss	Air flow		Noise ¹⁾	DC capacitance
	W	m ³ /h	ft ³ /min	dB (A)	mF
0640A-3	6700	1300	765	72	13.500
0760A-3	8600	1300	765	72	18.000
0830A-3	8900	1300	765	72	18.000
0900A-3	10000	1300	765	72	18.000
1250A-3	13000	2600	1530	74	27.000
1480A-3	16000	2600	1530	74	36.000
1760A-3	20000	2600	1530	74	36.000
2210A-3	23000	3900	2295	76	54.000
2610A-3	30000	3900	2295	76	54.000
3450A-3	40000	5200	3060	76	72.000
4290A-3	50000	6500	3825	77	90.000
5130A-3	60000	7800	4590	78	108.000
$U_n = 500 \text{ V}$					
003A6-5	60	24	14	47	0.280
004A8-5	70	24	14	47	0.280
006A0-5	80	24	14	47	0.280
008A0-5	90	24	14	47	0.280
0011A-5	130	48	28	39	0.435
0014A-5	150	48	28	39	0.865
0018A-5	180	48	28	39	0.865
0025A-5	230	142	84	63	0.785
0030A-5	280	142	84	63	0.785
0035A-5	320	142	84	63	0.785
0050A-5	480	200	118	71	1.178
0061A-5	550	290	171	70	1.570
0078A-5	650	290	171	70	2.355
0094A-5	800	290	171	70	2.355
0110A-5	1000	650	383	71	4.500
0140A-5	1200	650	383	71	4.500
0170A-5	1500	650	383	71	4.500
0200A-5	1800	650	383	71	4.500
0240A-5	2000	650	383	71	6.750
0300A-5	2700	940	553	72	9.000
0340A-5	3200	940	553	72	9.000
0440A-5	4700	1300	765	72	11.250
0590A-5	6300	1300	765	72	13.500
0670A-5	6900	1300	765	72	18.000
0740A-5	8100	1300	765	72	18.000
0810A-5	9300	1300	765	72	18.000
1150A-5	12000	2600	1530	74	27.000
1450A-5	16000	2600	1530	74	36.000

ACS880-104-...	Power loss	Air flow		Noise ¹⁾	DC capacitance
	W	m ³ /h	ft ³ /min	dB (A)	mF
1580A-5	18000	2600	1530	74	36.000
2150A-5	24000	3900	2295	76	54.000
2350A-5	27000	3900	2295	76	54.000
3110A-5	36000	5200	3060	76	72.000
3860A-5	44000	6500	3825	77	90.000
4610A-5	53000	7800	4590	78	108.000
$U_n = 690 \text{ V}$					
007A3-7	220	280	165	62	0.343
009A8-7	280	280	165	62	0.343
014A2-7	400	280	165	62	0.343
0018A-7	490	280	165	62	0.343
0022A-7	580	280	165	62	0.687
0027A-7	660	280	165	62	0.687
0035A-7	860	280	165	62	0.687
0042A-7	1000	280	165	62	0.687
0052A-7	1120	280	165	62	0.687
0062A-7	800	650	383	71	1.500
0082A-7	1100	650	383	71	1.500
0100A-7	1300	650	383	71	1.500
0130A-7	1500	650	383	71	3.000
0140A-7	1800	650	383	71	3.000
0190A-7	2500	650	383	71	3.000
0220A-7	2800	940	553	72	4.500
0270A-7	3300	940	553	72	4.500
0340A-7	4900	1300	765	72	6.000
0410A-7	5800	1300	765	72	6.000
0480A-7	6800	1300	765	72	9.000
0530A-7	7600	1300	765	72	9.000
0600A-7	8700	1300	765	72	9.000
0800A-7	11000	2600	1530	74	12.000
1030A-7	15000	2600	1530	74	18.000
1170A-7	17000	2600	1530	74	18.000
1540A-7	22000	3900	2295	76	27.000
1740A-7	25000	3900	2295	76	27.000
2300A-7	34000	5200	3060	76	36.000
2860A-7	42000	6500	3825	77	45.000
3420A-7	50000	7800	4590	78	54.000
3990A-7	58000	9100	5360	78	63.000
4560A-7	67000	10400	6120	79	72.000
5130A-7	75000	11700	6890	79	81.000

ACS880-104-...	Power loss	Air flow		Noise ¹⁾	DC capacitance
	W	m ³ /h	ft ³ /min	dB (A)	mF
5700A-7	83000	13000	7650	79	90.000

¹⁾ Measured in a typical ABB (ACS880-107) cabinet installation.

These losses are not calculated according to the ecodesign standard IEC 61800-9-2.

Permitted mounting orientations

The modules can be mounted upright or frames R6i...R8i also on right-hand side.

Frames R6i...R7i viewed from the front:

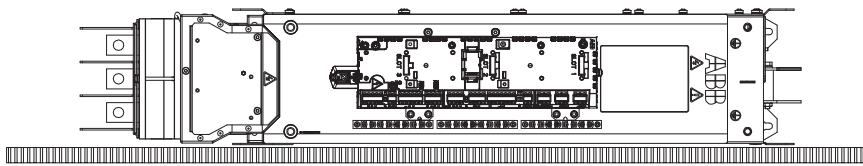

Frame R8i viewed from the front:

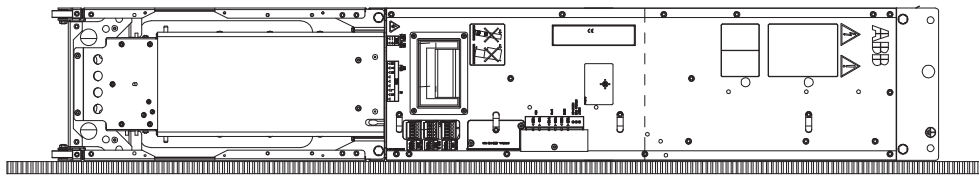

Dimensions and weights

The weights of the ACS880-104 modules are shown below. For the dimensions, refer to chapter [Dimension drawings \(page 425\)](#).

ACS880-104-...		Weight	
		kg	lbs
004A8-3 006A0-3 008A0-3	003A6-5 004A8-5 006A0-5 008A0-5	3	6.5
0011A-3 0014A-3 0018A-3	0011A-5 0014A-5 0018A-5	5	11
0025A-3 0035A-3 0044A-3 0050A-3	0025A-5 0030A-5 0035A-5 0050A-5	10	22

ACS880-104-...			Weight	
			kg	lbs
		007A3-7 009A8-7 014A2-7 0018A-7 0022A-7 0027A-7 0035A-7 0042A-7 0052A-7	14	31
0061A-3 0078A-3 0094A-3 0100A-3	0061A-5 0078A-5 0094A-5		17	38
0140A-3 0170A-3 0210A-3 0250A-3	0110A-5 0140A-5 0170A-5 0200A-5 0240A-5	0062A-7 0082A-7 0100A-7 0130A-7 0140A-7 0190A-7	38	84
0300A-3 0350A-3	0300A-5 0340A-5	0220A-7 0270A-7	42	93
0470A-3 0640A-3 0760A-3 0830A-3 0900A-3	0440A-5 0590A-5 0670A-5 0740A-5 0810A-5	0340A-7 0410A-7 0480A-7 0530A-7 0600A-7	125	275

Free space requirements

ACS880-104-...			Above ¹⁾		Below ²⁾		Front ³⁾		Left/Right ⁴⁾	
			mm	inch	mm	inch	mm	inch	mm	inch
004A8-3 006A0-3 008A0-3 0011A-3 0014A-3 0018A-3	003A6-5 004A8-5 006A0-5 008A0-5 0011A-5 0014A-5 0018A-5		150 ⁵⁾	5.9 ⁵⁾	125	4.9	0	0.0	2.5	0.1
0025A-3 0035A-3 0044A-3 0050A-3	0025A-5 0030A-5 0035A-5 0050A-5		150 ⁵⁾	5.9 ⁵⁾	150	5.9	0	0.0	2.5	0.1
0061A-3 0078A-3 0094A-3 0100A-3	0061A-5 0078A-5 0094A-5		150 ⁵⁾	5.9 ⁵⁾	175	6.9	0	0.0	2.5	0.1

ACS880-104-...			Above ¹⁾		Below ²⁾		Front ³⁾		Left/Right ⁴⁾	
			mm	inch	mm	inch	mm	inch	mm	inch
		007A3-7 009A8-7 014A2-7 0018A-7 0022A-7 0027A-7 0035A-7 0042A-7 0052A-7	200	7.9	150	5.9	0	0.0	10	0.4
0140A-3 0170A-3 0210A-3 0250A-3 0300A-3 0350A-3	0110A-5 0140A-5 0170A-5 0200A-5 0240A-5 0300A-5 0340A-5	0062A-7 0082A-7 0100A-7 0130A-7 0140A-7 0190A-7 0220A-7 0270A-7	150	5.9	150	5.9	0	0.0	25	1.0
0470A-3 0640A-3 0760A-3 0830A-3 0900A-3	0440A-5 0590A-5 0670A-5 0740A-5 0810A-5	0340A-7 0410A-7 0480A-7 0530A-7 0600A-7	200	7.9	-	-	10	0.4	10	0.4

1) Required by cooling air flow or 2) air guide

2) Required by cooling air flow and/or cabling

3) Additional free space can be required by options installed on control unit, and control wiring

4) Additional space required for smooth installation

5) Required by cooling air guide

Input power (DC) connection

Voltage (U_1)	ACS880-104-xxxxx-3: 513...566 V DC. This is indicated in the type designation label as typical input voltage level (566 V DC). ACS880-104-xxxxx-5: 513...707 V DC. This is indicated in the type designation label as typical input voltage levels (566/679/707 V DC). ACS880-104-xxxxx-7: 709...976 V DC. This is indicated in the type designation label as typical input voltage levels (742/849/976 V DC).
-------------------	--

Motor connection data

Motor types	Asynchronous AC induction motors, permanent magnet synchronous motors, AC induction servomotors and ABB synchronous reluctance (SynRM) motors
-------------	---

Voltage (U_2)	<p>3-phase symmetrical, U_{max} at field weakening point</p> <p>ACS880-104-xxxx-3: 0...400 V AC. The maximum value (400 V) is a typical drive input voltage level shown on the type designation label of the supply unit corresponding to 380...415 V AC.</p> <p>ACS880-104-xxxx-5: 0...400/480/500 V AC. The maximum values (400/480/500 V) are typical drive input voltage levels shown on the type designation label of the supply unit corresponding to 380...500 V AC.</p> <p>ACS880-104-xxxx-7: 0...525/600/690 V AC. The maximum values (525/600/690 V) are typical drive input voltage levels shown on the type designation label of the supply unit corresponding to 525...690 V AC.</p>
Frequency (f_2)	<p>0...500 Hz</p> <p>0...120 Hz with sine output filters (option +E206)</p> <p>0...120 Hz for frames R1i...R5i with du/dt filters (option +E205)</p> <p>0...200 Hz for frames R6i and R7i with du/dt filters (option +E205)</p> <ul style="list-style-type: none"> For higher operational output frequencies, contact your local ABB representative. Operation at frequencies higher than 150 Hz can require derating. For more information, contact your local ABB representative.
Current	Refer to the technical data.
Switching frequency	<p><u>Frames R1i...R4i</u>: 4.5 kHz (typical)</p> <p><u>Frames R5i...R8i</u>: 3 kHz (typical)</p> <p>The switching frequency can vary per frame and voltage. For exact values, contact your local ABB representative.</p>
Maximum recommended motor cable length	<p><u>Frames R1i...R2i</u>: 150 m (492 ft)¹⁾</p> <p><u>Frames R3i...R7i</u>: 300 m (984 ft)¹⁾</p> <p><u>Frame R8i and multiples</u>: 500 m (1640 ft)</p> <p>Note: Longer cables cause a motor voltage decrease which limits the available motor power. The decrease depends on the motor cable length and characteristics. Contact ABB for more information.</p> <p>Note: The maximum motor cable length for the EMC compliance is 100 m (328 ft).</p>

¹⁾ Tested with 100 m (328 ft) for EMC Category C3. See standards and markings information in [ACS880 multidrives cabinets and modules electrical planning instructions \(3AUA0000102324 \[English\]\)](#).

Typical power cable sizes

The tables below give the current carrying capacity (I_{Lmax}) and typical size for copper and aluminum cables with PVC or XLPE insulation. A correction factor $K = 0.70$ is used. Time const. is the temperature time constant of the cable.

The cable sizing is based on a maximum of 9 cables installed side by side on a ladder-type cable tray, with three trays on top of each other (with 30 cm of space between the trays), and an ambient temperature of 30 °C (IEC 60364-5-52).

The notation "3 × P + S" indicates a symmetrical, shielded cable that includes: three phase conductors, each with a cross-sectional area P (mm²), and one concentric PE conductor with a cross-sectional area S (mm²). If the notation includes a multiplier before the brackets, it indicates parallel cables.

Conductor cross-section (copper)		PVC insulation Conductor temperature 70°		XLPE insulation Conductor temperature 90°		Typical dimensions of copper cable	
mm ²	AWG / kcmil	I_{Lmax} (A)	Time const. (s)	I_{Lmax} (A)	Time const. (s)	Size	ø [mm]
1.5	16	13	85	16	67	3 × 1.5 + 1.5	13
2.5	12	18	121	23	88	3 × 2.5 + 2.5	14
4	12	24	175	30	133	3 × 4 + 4	16
6	10	30	251	38	186	3 × 6 + 6	18
10	8	42	359	53	268	3 × 10 + 10	21
16	6	56	514	70	391	3 × 16 + 16	23
25	4	71	791	89	598	3 × 25 + 16	24
35	1	88	1000	110	760	3 × 35 + 16	26
50	1/0	107	1308	134	990	3 × 50 + 25	29
70	2/0	137	1613	171	1230	3 × 70 + 35	32
95	4/0	167	2046	209	1551	3 × 95 + 50	38
120	250	193	2441	241	1859	3 × 120 + 70	41
150	300	223	2820	279	2139	3 × 150 + 70	44
185	400	255	3329	319	2525	3 × 185 + 95	50
240	500	301	4073	376	3099	3 × 240 + 120	55
300	600	348	4779	435	3636	3 × 300 + 150	58

Conductor cross-section (aluminum)		PVC insulation Conductor temperature 70°		XLPE insulation Conductor temperature 90°		Typical dimensions of aluminum cable	
mm ²	AWG / kcmil	I_{Lmax} (A)	Time const. (s)	I_{Lmax} (A)	Time const. (s)	Size	ø [mm]
35	1	67	736	84	669	3 × 35 + 10 Cu	26
50	1/0	82	959	102	874	3 × 50 + 15 Cu	29
70	2/0	105	1182	131	1079	3 × 70 + 21 Cu	32
95	4/0	128	1492	159	1376	3 × 95 + 29 Cu	38
120	250	148	1776	184	1637	3 × 120 + 41 Cu	41
150	300	171	2042	213	1881	3 × 150 + 41 Cu	44
185	400	196	2422	243	2237	3 × 185 + 57 Cu	49

Conductor cross-section (aluminum)		PVC insulation Conductor temperature 70°		XLPE insulation Conductor temperature 90°		Typical dimensions of aluminum cable	
mm ²	AWG / kcmil	I _{Lmax} (A)	Time const. (s)	I _{Lmax} (A)	Time const. (s)	Size	ø [mm]
240	500	231	2967	286	2740	3 × 240 + 72 Cu	54
300	600	267	3478	330	3229	3 × 300 + 88 Cu	58

Terminal data for the power cables

■ Input terminals

Frame size	UDC+, UDC-		PE
	Conductor size	Tightening torque	Tightening torque
R1i	0.25 ... 4 mm ²	0.5 ... 0.6 N·m (4.4 ... 5.3 lbf·in)	1.5 N·m (13 lbf·in)
R2i	0.5 ... 6 mm ²	1.2 ... 1.5 N·m (10.6 ... 13.3 lbf·in)	1.5 N·m (13 lbf·in)
R3i...R5i	6...70 mm ²	<u>Allen screw:</u> 15 N·m (11 lbf·ft) <u>Connection post:</u> 4 N·m (30 lbf·in) <u>Connector cover screws:</u> 3 N·m (25 lbf·in)	3 N·m (25 lbf·in) (screw size M5)
R6i...R7i	Refer to chapter Dimension drawings and section One R6i/R7i module in a 400 mm wide Rittal VX25 enclosure (page 112) .		
R8i and multiples	M12, maximum intrusion into module 20 mm (0.8"). Refer to chapter Dimension drawings and section One R8i module in a 400 mm wide Rittal VX25 enclosure (page 127) .		

■ Output terminals (frames R1i...R5i)

Frame size	U2, V2, W2		PE
	Conductor size	Tightening torque	Tightening torque
R1i	0.25 ... 4 mm ²	0.5 ... 0.6 N·m (4.4 ... 5.3 lbf·in)	1.5 N·m (13 lbf·in)
R2i	0.5 ... 6 mm ²	1.2 ... 1.5 N·m (10.6 ... 13.3 lbf·in)	1.5 N·m (13 lbf·in)
R3i...R5i	6...70 mm ²	<u>Allen screw:</u> 15 N·m (11 lbf·ft) <u>Connection post:</u> 4 N·m (30 lbf·in) <u>Connector cover screws:</u> 3 N·m (25 lbf·in)	3 N·m (25 lbf·in) (screw size M5)

■ **Output terminals (frames R6i...R7i)**

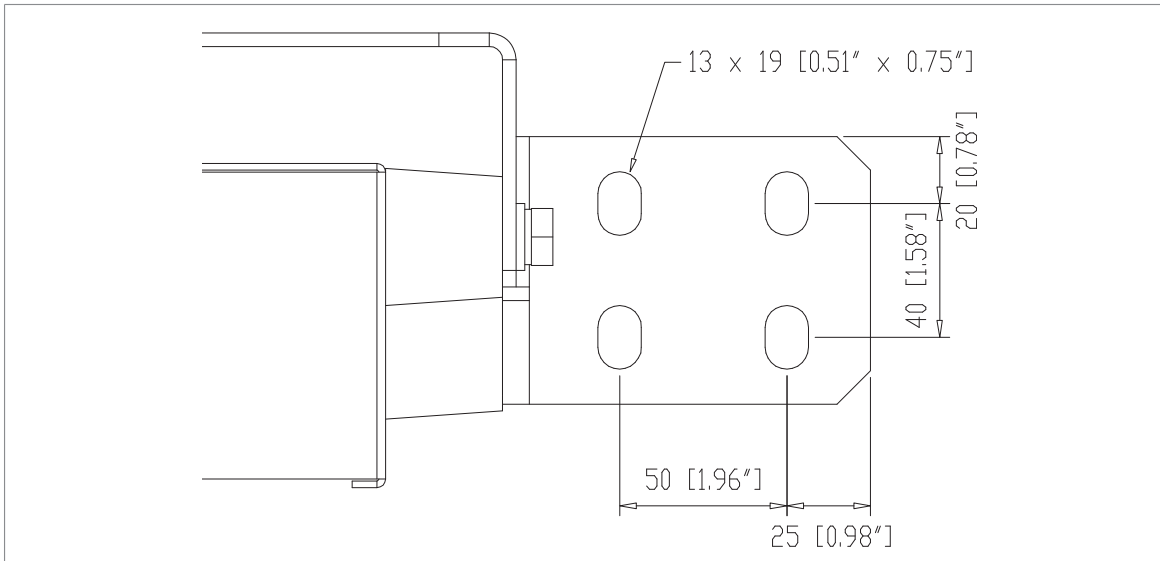

Screw size: M12 or 1/2". Tightening torque: 70 N·m (52 lbf·ft)

Busbar material: Tin-plated copper

■ **Output terminals (frame R8i)**

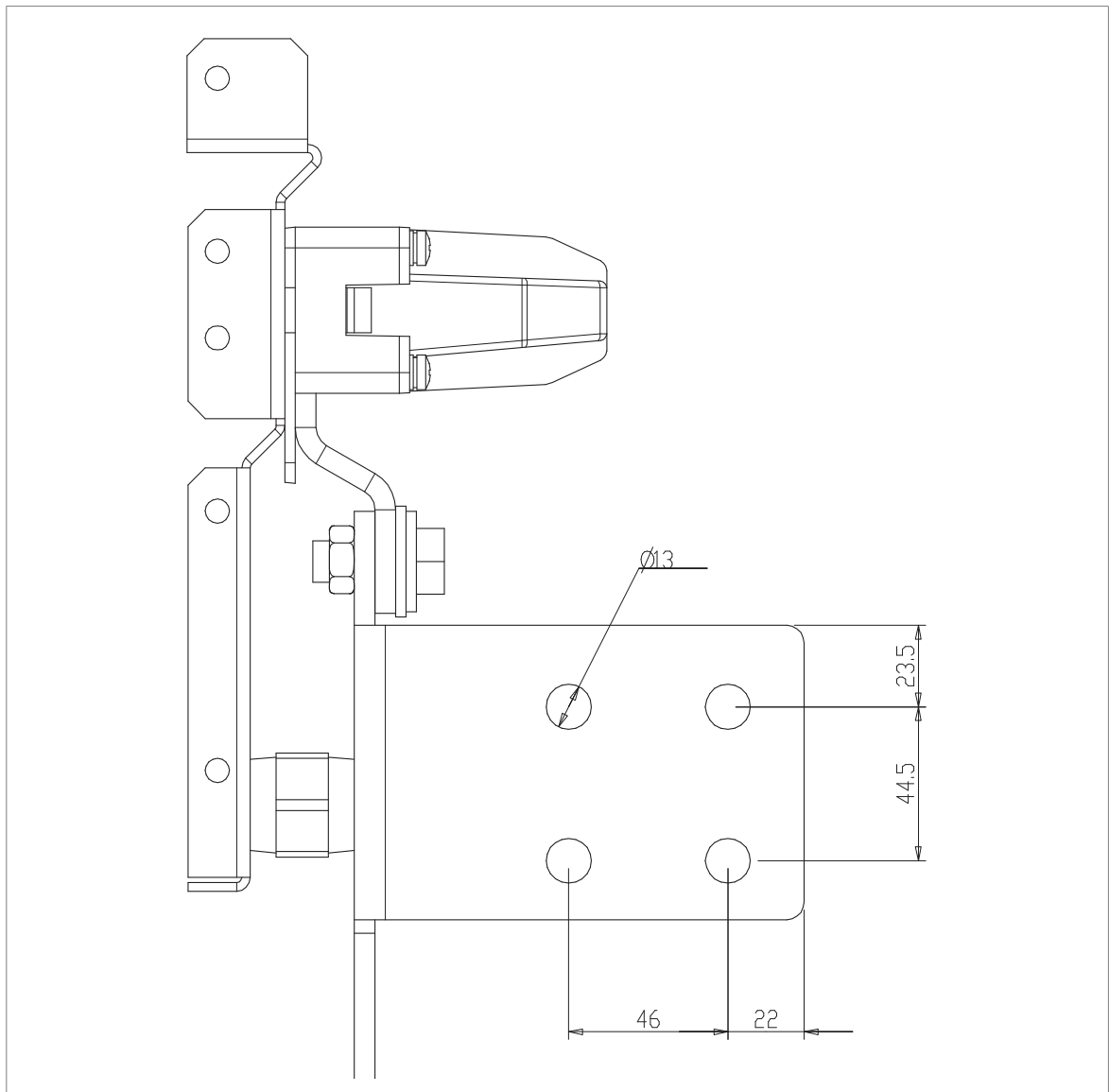

Screw size: M12 or ½". Tightening torque: 70 N·m (52 lbf·ft)

Busbars to quick connector: M12. Tightening torque: 50 N·m (37 lbf·ft)

Busbars to support insulators: M8. Tightening torque: 9 N·m (6.5 lbf·ft)

Busbar material: Tin-plated copper

Control connections

Refer to chapters [UCU-22](#), [UCU-23](#) and [UCU-24 control units](#) and [BCU](#) and [ZCU control units](#).

Protection classes for modules

Degrees of protection (IEC/EN 60529)	IP00 (frames R6i...R8i) IP20 (frames R1i...R5i)
Enclosure types (UL 50/50E)	UL Open Type
Overvoltage category (IEC/EN 60664-1)	III
Protective class (IEC/EN 61800-5-1)	I

Ambient conditions

Environmental limits for the drive system are given below. The drive system is to be used in a heated, indoor, controlled environment.

	Operation installed for stationary use	Storage in the protective package	Transportation in the protective package
Installation site altitude above sea level	1. <u>Frame R1i...R4i</u> <u>module</u> : 0...2000 m (6561 ft) 2. <u>Frame R5i...R8i</u> <u>module</u> : 0...4000 m (13123 ft) Output derated above 1000 m (3281 ft).	-	-
	For supply network types, see section Input power (DC) connection (page 374) .		
Air temperature	0 ... +40 °C (+32 ... +104 °F). No condensation allowed. Output derated in the range +40 ... +50 °C (+104 ... +122 °F). See section Ambient temperature derating.	-40 to +70 °C (-40 to +158 °F)	-40 to +70 °C (-40 to +158 °F)
Relative humidity	5 to 95%	Max. 95%	Max. 95%
	No condensation allowed. Maximum allowed relative humidity is 60% in the presence of corrosive gases.		
Contamination	IEC/EN 60721-3-3:2002: Classification of environmental conditions - Part 3-3: Classification of groups of environmental parameters and their severities - Stationary use of weather protected locations	IEC 60721-3-1	IEC 60721-3-2
Chemical gases	Class 3C2	Class 1C2	Class 2C2
Solid particles	Class 3S1. No conductive dust allowed.	Class 1S3 (packing must support this, otherwise 1S2)	Class 2S2

Vibration IEC 61800-5-1 IEC 60068-2-6:2007, EN 60068-2-6:2008 Environmental testing Part 2: Tests - Test Fc: Vi- bration (sinusoidal)	10...57 Hz: max. 0.075 mm amplitude 58...150 Hz: 1 g Tested in ABB multidrive cabinet (ACS880-x07) according to: Max. 1 mm (0.04 in.) (5 ... 13.2 Hz), max. 0.7 g (13.2 ... 100 Hz) sinusoidal	For modules and cabinets in packages: IEC/EN 60721-3-1:1997 Classification of environ- mental conditions - Part 3: Classification of groups of environmental parameters and their severities - Section 1: Storage	For cabinet package: IEC/EN 60721-3-1:1997 Classification of environ- mental conditions - Part 3: Classification of groups of environmental parameters and their severities - Section 2: Transportation
Shock IEC 60068-2-27:2008, EN 60068-2-27:2009 Environmental testing - Part 2-27: Tests - Test Ea and guidance: Shock	Not allowed	With packing max. 100 m/s ² (330 ft./s ²) 11 ms	With packing max. 100 m/s ² (330 ft./s ²) 11 ms

Colors

RAL 9002 / PMS 1C Cool Gray, RAL 9017, NCS 1502-Y

Materials

■ Module

Refer to [ACS880 cabinet-installed drives and multidrive modules recycling instructions and environmental information \(3AXD50000153909 \[English\]\)](#).

■ Packaging of module

This is a complete list of the package materials. The materials vary depending on the frame size (packages do not contain all materials listed below).

- Cardboard (heavy duty quality with wet strength glue in large modules)
- Molded pulp
- Plywood
- Wood
- PP (strapping)
- EPP (foam)
- PE (plastic bag and/or VCI film)
- Metal (fixing clamps, screws).

■ Packaging of options

- Cardboard
 - Kraft paper
 - PP (straps)
 - PE (film, bubble wrap)
 - Plywood, wood (only for heavy components)
-

The materials vary by item type, size, and shape. The typical package is a cardboard box with paper filling or bubble wrap. ESD-safe packaging is used for printed circuit boards and similar items.

■ **Manuals**

Printed product manuals are made of recyclable paper.

Disposal

The main parts of the product can be recycled to preserve natural resources and energy. Product parts and materials should be dismantled and separated.

In general, all metals, such as steel, aluminum, copper, and its alloys, and precious metals can be recycled. Plastics, rubber, cardboard, and other packaging materials can be used in energy recovery.

Printed circuit boards and DC capacitors require selective treatment according to IEC 62635 guidelines.

To aid recycling, most plastic parts are marked with an appropriate identification code. Components that contain Substances of Very High Concern (SVHCs) are listed in the European Chemicals Agency SCIP database. SCIP is the database for information on Substances of Concern in articles as such or in complex objects (products) established under the Waste Framework Directive (2008/98/EC). For more information, contact your local ABB distributor or consult the European Chemicals Agency SCIP database to determine which SVHCs are used in the product and where the components are located.

Contact your local ABB distributor for more information on environmental aspects. End-of-life treatment must obey international and national regulations.

For more information on ABB end-of-life services, refer to new.abb.com/service/end-of-life-services.

Standards

Refer to [ACS880 multidrives cabinets and modules electrical planning instructions \(3AUA0000102324 \[English\]\)](#).

Markings

Refer to [ACS880 multidrives cabinets and modules electrical planning instructions \(3AUA0000102324 \[English\]\)](#).

Efficiency

Approximately 98% at nominal power level.

The efficiency is not calculated according to the ecodesign standard IEC 61800-9-2.

Energy efficiency data (ecodesign)

Energy efficiency data is not provided for the drive/unit. Multidrives and multidrive modules are not in the scope of the EU ecodesign requirements (Regulation EU/2019/1781) or the UK ecodesign requirements (Regulation SI 2021 No. 745).

Auxiliary power consumptions

■ Control equipment

Device	U_n	f Hz	I_{cont} A	I_{start} A	P_{cont} W
UCU-22, UCU-23 or UCU-24 control unit	24 V DC (+30%/-20%)	-	2.5 ¹⁾	-	60
ZCU/BCU control unit	24 V DC (+10%)	-	2.0	-	48
R8i module: internal electronics	230 V AC (+15%/-20%)	50/60	0.45	-	105
	115 V AC (+15%/-20%)	50/60	0.9	-	105
R8i module: heating element (option +C183)	230 V AC	50/60	-	-	40
	115 V AC	60	-	-	40
R8i module: direct-on-line fan (option +C188)	400 V AC	50	1.5	3.0	-
		60	1.9	3.8	-
	320 V AC	60	1.5	4.4	-
Charging controller	230 V AC (+10%/-15%)	50/60	0.04	-	-
	115 V AC (+10%/-15%)	50/60	0.08	-	-
PDAL2 switch/disconnector interlock coil	230 V AC (+10%/-30%)	50	-	-	6.5
	240 V AC (+10%/-30%)	60	-	-	6.5
	110 V AC (+10%/-30%)	60	-	-	6.5

¹⁾ The value is applicable in these conditions: UCU-24 control unit, with 24 V DC power supply, with control panel, with 4 relay outputs in use, with all analog outputs at maximum current, with RDCO module and 3 option modules installed, and with 8 inverter modules in the STO circuit.

■ Cabinet cooling fans

Frame size	Enclosure width (IEC, UL)	U_n V AC	f Hz	I_{cont} A
R1i...R5i (IP20/IP42 roof fan)	400/600/800 mm (IEC/UL)	230	50	0.77
			60	0.96
	400/600/800 mm (UL)	115	60	1.81
R1i...R8i (IP54 roof fan)	400/800 mm (IEC/UL)	230	50	1.1
			60	1.45
	600 mm (IEC/UL)	230	50	2.3
			60	3.0
	400/800 mm (UL)	115	60	3.9
	600 mm (UL)	115	60	6.3

■ Definitions

f	Supply frequency
I_{cont}	Continuous current consumption
I_{start}	Calculated load current at start
P_{cont}	Continuous input power

U_n	Voltage requirement
-------	---------------------

Fuse data

■ Ferrules used with 400 V and 500 V units

Rating A rms	Class	Example	Power loss at I_n	Clearing βt		U_n
			W	A ² s	V	V
10	aR	Bussmann FWP-10A14Fa	4	22	660	660 (IEC) 700 (UL)
15	aR	Bussmann FWP-15A14Fa	5.5	75	660	
20	aR	Bussmann FWP-20A14Fa	6	180	660	
25	aR	Bussmann FWP-25A14Fa	7	320	660	
32	aR	Bussmann FWP-32A14Fa	7.6	600	660	
50	aR	Mersen 6,921 CP URQ 27x60/50	16	610	690	690
63	aR	Mersen 6,921 CP URQ 27x60/63	21	860	690	
80	aR	Mersen 6,921 CP URQ 27x60/80	24	1880	690	
100	aR	Mersen 6,921 CP URQ 27x60/100	27	3210	690	
125	aR	Mersen 6,921 CP URQ 27x60/125	30	6970	690	
160	aR	Mersen 6,921 CP URQ 27x60/160	34	15000	690	
200	aR	Mersen 6,921 CP URQ 27x60/200	38	30000	690	

■ Ferrules used with 690 V units

Rating A rms	Class	Example	Power loss at I_n	Clearing βt		U_n
			W	A ² s	V	V
40	aR	Mersen 1021 CP URB 27x60/40	17	450	1000	1000
100	aR	Mersen 1021 CP URB 27x60/100	27	6000	1000	

■ **Flush-end fuse blocks used with 400 V and 500 V units**

Rating A rms	Class	Example	Power loss at I_n	Clearing I^2t		Size	U_n
			W	A ² s	V		V
250	aR	Bussmann 170M4409	55	21000	660	1	690 (IEC) 700 (UL)
315	aR	Bussmann 170M4410	58	42000	660		
400	aR	Bussmann 170M4412	65	91500	660		
450	aR	Bussmann 170M4413	70	120000	660		
500	aR	Bussmann 170M4414	72	170000	660		
630	aR	Bussmann 170M4416	80	350000	660		
700	aR	Bussmann 170M4417	85	465000	660		
800	aR	Bussmann 170M4418	95	725000	660	3	
900	aR	Bussmann 170M6413	120	670000	660		
1100	aR	Bussmann 170M6415	130	1300000	660		
1250	aR	Bussmann 170M6416	140	1950000	660		
1400	aR	Bussmann 170M6417	155	2450000	660		
1600	aR	Bussmann 170M6419	160	3900000	660		

■ **Flush-end fuse blocks used with 690 V units**

Rating A rms	Class	Example	Power loss at I_n	Clearing I^2t		Size	U_n	
			W	A ² s	V		V	
125	aR	Bussmann 170M3392	35	9000	1000	1*	690 (IEC) 700 (UL)	
160	aR	Bussmann 170M4388	45	11500	1000	1		
200	aR	Bussmann 170M4389	50	22500	1000			
250	aR	Bussmann 170M4390	60	4600	1000			
315	aR	Bussmann 170M4391	65	9000	1000			
350	aR	Bussmann 170M4392	70	125000	1000			
400	aR	Bussmann 170M4393	75	175000	1000			3
500	aR	Bussmann 170M4395	85	340000	1000	1100 (IEC)		
630	aR	Bussmann 170M6544	115	495000	1000	1250 (IEC), 1300 (UL)		
800	aR	Bussmann 170M6546	125	995000	1000			
1000	aR	Bussmann 170M6548	135	2150000	1000		1100 (IEC)	
1100	aR	Bussmann 170M6549	140	2800000	1000		1000 (IEC)	

Tightening torques

Unless a tightening torque is specified in the text, these torques can be used.

For Rittal components, use the torques given in the Rittal assembly documentation.

■ Electrical connections

Size	Torque	Strength class
M3	0.5 N·m (4.4 lbf·in)	4.6...8.8
M4	1 N·m (9 lbf·in)	4.6...8.8
M5	4 N·m (35 lbf·in)	8.8
M6	9 N·m (6.6 lbf·ft)	8.8
M8	22 N·m (16 lbf·ft)	8.8
M10	42 N·m (31 lbf·ft)	8.8
M12	70 N·m (52 lbf·ft)	8.8
M16	120 N·m (90 lbf·ft)	8.8

■ Mechanical connections

Size	Max. torque	Strength class
M5	6 N·m (53 lbf·in)	8.8
M6	10 N·m (7.4 lbf·ft)	8.8
M8	24 N·m (17.7 lbf·ft)	8.8

■ Insulation supports

Size	Max. torque	Strength class
M6	5 N·m (44 lbf·in)	8.8
M8	9 N·m (6.6 lbf·ft)	8.8
M10	18 N·m (13.3 lbf·ft)	8.8
M12	31 N·m (23 lbf·ft)	8.8

■ Cable lugs

Size	Max. torque	Strength class
M8	15 N·m (11 lbf·ft)	8.8 (A2-70 or A4-70)
M10	32 N·m (23.5 lbf·ft)	8.8
M12	50 N·m (37 lbf·ft)	8.8

Disclaimers

■ Generic disclaimer

The manufacturer shall have no obligation with respect to any product which (i) has been improperly repaired or altered; (ii) has been subjected to misuse, negligence or accident; (iii) has been used in a manner contrary to the manufacturer's instructions; or (iv) has failed as a result of ordinary wear and tear.

■ Cyber security disclaimer

This product is designed to be connected to and to communicate information and data via a network interface. It is the Customer's sole responsibility to provide and continuously ensure a secure connection between the product and the Customer network or any other network (as the case may be). The Customer shall establish and maintain any appropriate measures (such as but not limited to the installation of firewalls, application of authentication measures, encryption of data, installation of anti-virus programs, etc.) to protect the product, the network, its system and the interface against any kind of security breaches, unauthorized access, interference, intrusion, leakage and/or theft of data or information.

ABB and its affiliates are not liable for damages and/or losses related to such security breaches, any unauthorized access, interference, intrusion, leakage and/or theft of data or information.

Declarations of conformity

See [ACS880 multidrives cabinets and modules electrical planning instructions \(3AUA0000102324 \[English\]\)](#).

13

The Safe torque off function

Contents of this chapter

This chapter describes the Safe torque off (STO) function of the drive and gives instructions for its use.

Note: In this chapter, the term 'drive' refers to one inverter unit of the drive system.

Description



▲WARNING In case of parallel-connected drives or dual-winding motors, the STO must be activated on each drive to remove the torque from the motor.

The Safe torque off function can be used, for example, as the final actuator device of safety circuits (such as an emergency stop circuit) that stop the drive in case of danger. Another typical application is a prevention of unexpected start-up function that enables short-time maintenance operations like cleaning or work on non-electrical parts of the machinery without switching off the power supply to the drive.

When activated, the Safe torque off function disables the control voltage for the power semiconductors of the drive output stage, thus preventing the drive from generating the torque required to rotate the motor. If the motor is running when Safe torque off is activated, it coasts to a stop.

The Safe torque off function has a redundant architecture, that is, both channels must be used in the safety function implementation. The safety data given in this manual is calculated for redundant use, and does not apply if both channels are not used.

The Safe torque off function complies with these standards:

Standard	Name
IEC 60204-1:2021 EN 60204-1:2018	Safety of machinery – Electrical equipment of machines – Part 1: General requirements
IEC 61000-6-7:2014	Electromagnetic compatibility (EMC) – Part 6-7: Generic standards – Immunity requirements for equipment intended to perform functions in a safety-related system (functional safety) in industrial locations
IEC 61326-3-1:2017	Electrical equipment for measurement, control and laboratory use – EMC requirements – Part 3-1: Immunity requirements for safety-related systems and for equipment intended to perform safety-related functions (functional safety) – General industrial applications
IEC 61508-1:2010	Functional safety of electrical/electronic/programmable electronic safety-related systems – Part 1: General requirements
IEC 61508-2:2010	Functional safety of electrical/electronic/programmable electronic safety-related systems – Part 2: Requirements for electrical/electronic/programmable electronic safety-related systems
IEC 61511-1:2017	Functional safety – Safety instrumented systems for the process industry sector
IEC 61800-5-2:2016 EN 61800-5-2:2007	Adjustable speed electrical power drive systems – Part 5-2: Safety requirements – Functional
EN IEC 62061:2021	Safety of machinery – Functional safety of safety-related control systems
EN ISO 13849-1:2015	Safety of machinery – Safety-related parts of control systems – Part 1: General principles for design
EN ISO 13849-2:2012	Safety of machinery – Safety-related parts of control systems – Part 2: Validation

The function also corresponds to Prevention of unexpected start-up as specified by EN ISO 14118:2018 (ISO 14118:2017), and Uncontrolled stop (stop category 0) as specified in EN/IEC 60204-1.

■ Compliance with the European Machinery Directive and the UK Supply of Machinery (Safety) Regulations

Refer to [ACS880 multidrive cabinets and modules electrical planning instructions \(3AUA0000102324 \[English\]\)](#).

Wiring

For the electrical specifications of the STO connection, refer the technical data of the control unit.

■ Activation switch

In the wiring diagrams, the activation switch has the designation [K]. This represents a component such as a manually operated switch, an emergency stop push button switch, or the contacts of a safety relay or safety PLC.

- In case a manually operated activation switch is used, the switch must be of a type that can be locked out to the open position.
- The contacts of the switch or relay must open/close within 200 ms of each other.
- An FSO, FSPS, FSCS, or FPTC module can also be used. For more information, see the module documentation.

■ Cable types and lengths

- ABB recommends double-shielded twisted-pair cable.
- Maximum cable lengths:
 - 300 m (1000 ft) between activation switch [K] and drive control unit
 - 60 m (200 ft) between multiple drives
 - 60 m (200 ft) between external power supply and first control unit
 - 30 m (100 ft) between control unit and last inverter module in the chain.

Note: A short-circuit in the wiring between the switch and an STO terminal causes a dangerous fault. Therefore, it is recommended to use a safety relay (including wiring diagnostics) or a wiring method (shield grounding, channel separation) which reduces or eliminates the risk caused by the short-circuit.

Note: The voltage at the STO input terminals of the control unit (or frame R8i inverter module) must be at least 17 V DC to be interpreted as “1”.

The pulse tolerance of the input channels is 1 ms.

■ Grounding of protective shields

- Ground the shield in the cabling between the activation switch and the control unit at the control unit only.
 - Ground the shield in the cabling between two control units at one control unit only.
 - Do not ground the shield in the cabling between control unit and inverter module, or between inverter modules.
-

■ **Dual-channel connection with internal power supply**

Frames R1i...R7i (R6i/R7i without option +C249), with ZCU control unit

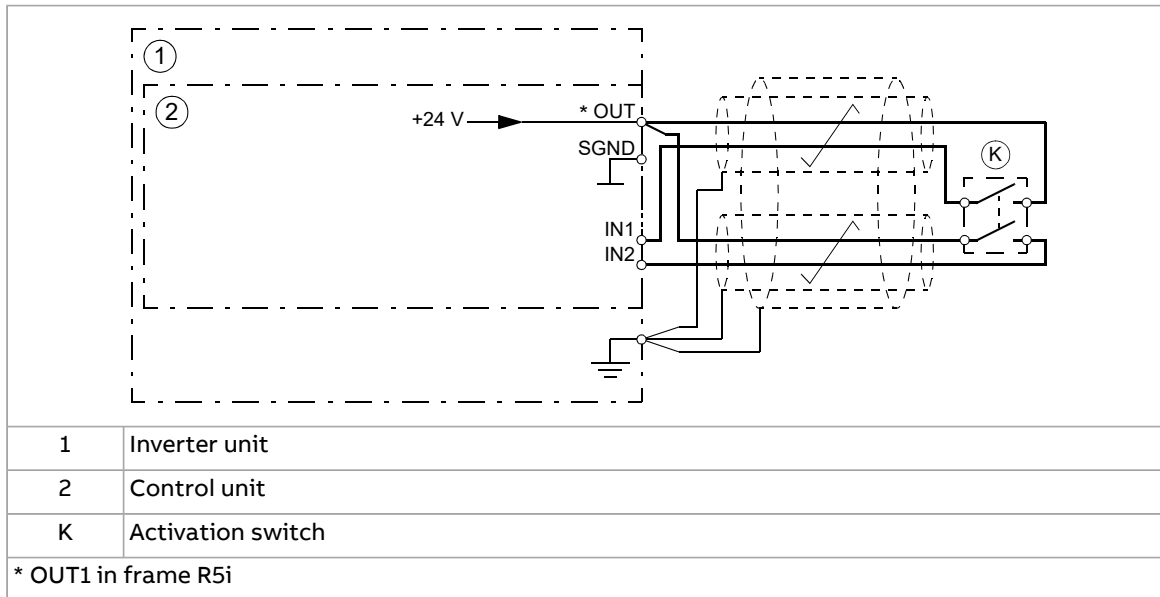

Frame R6i/R7i with option +C249, with BCU control unit

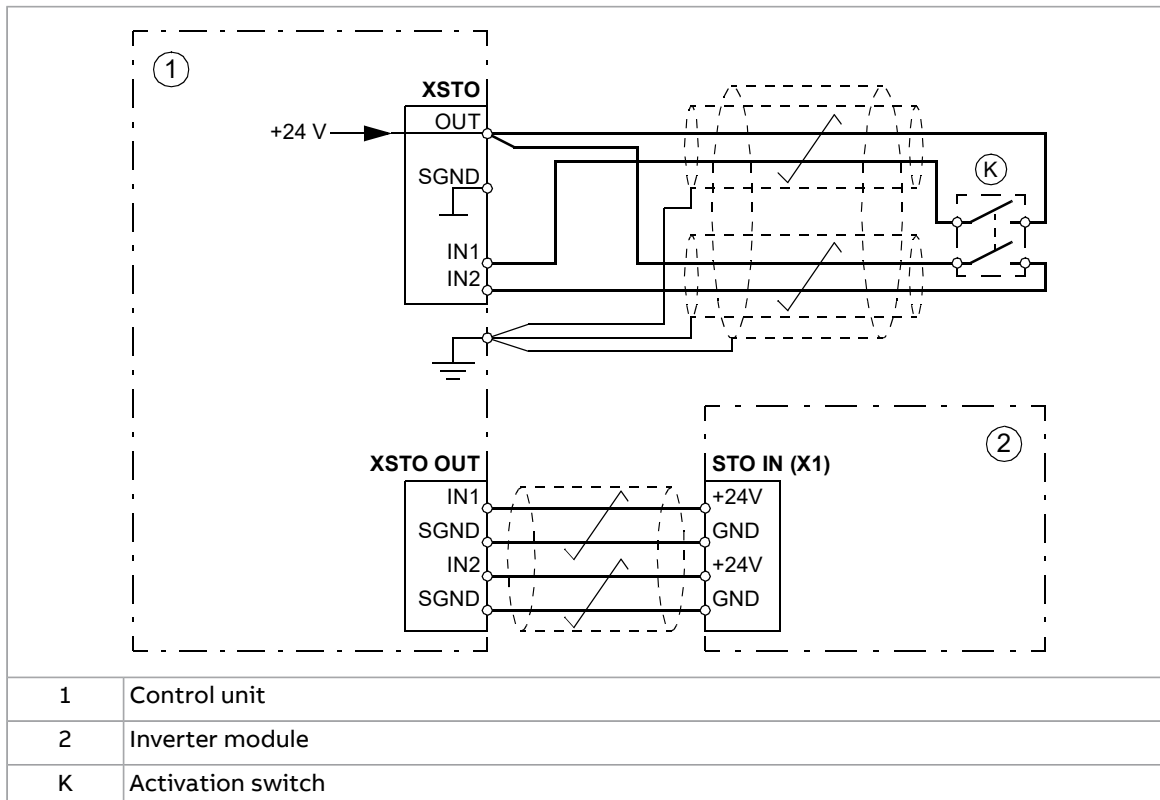

Frame R6i/R7i with option +C249, with UCU-22...24 control unit

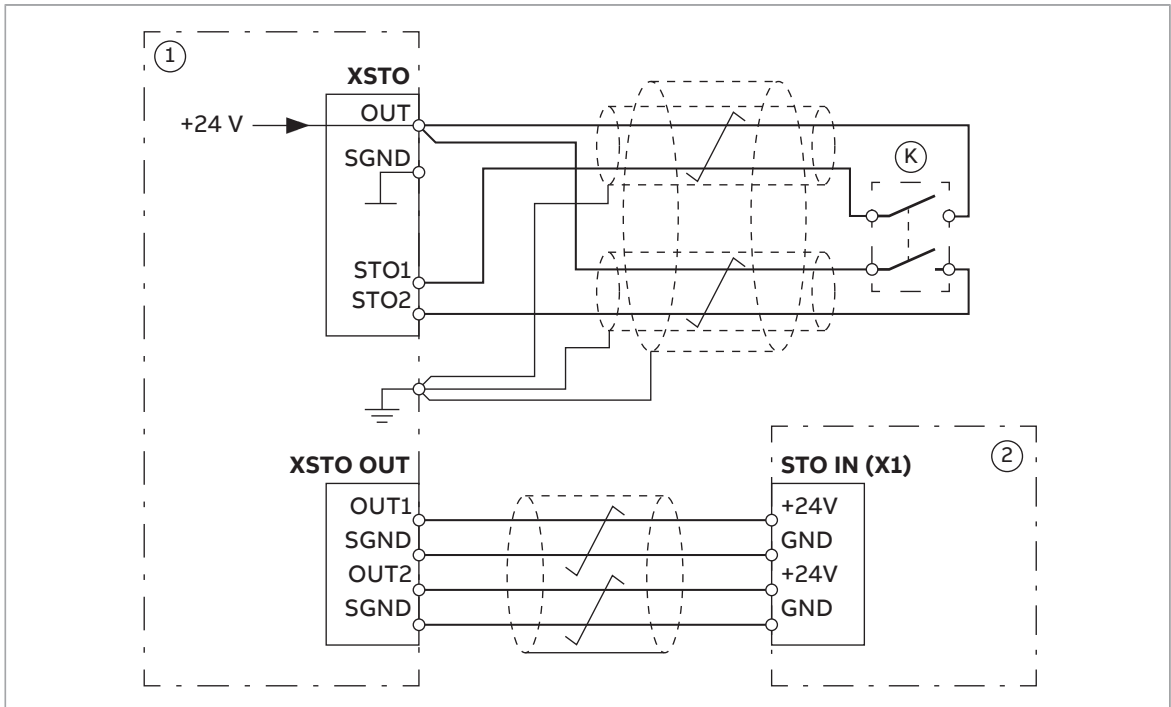

1	Control unit
2	Inverter module
K	Activation switch

Frame R8i and multiples with BCU control unit

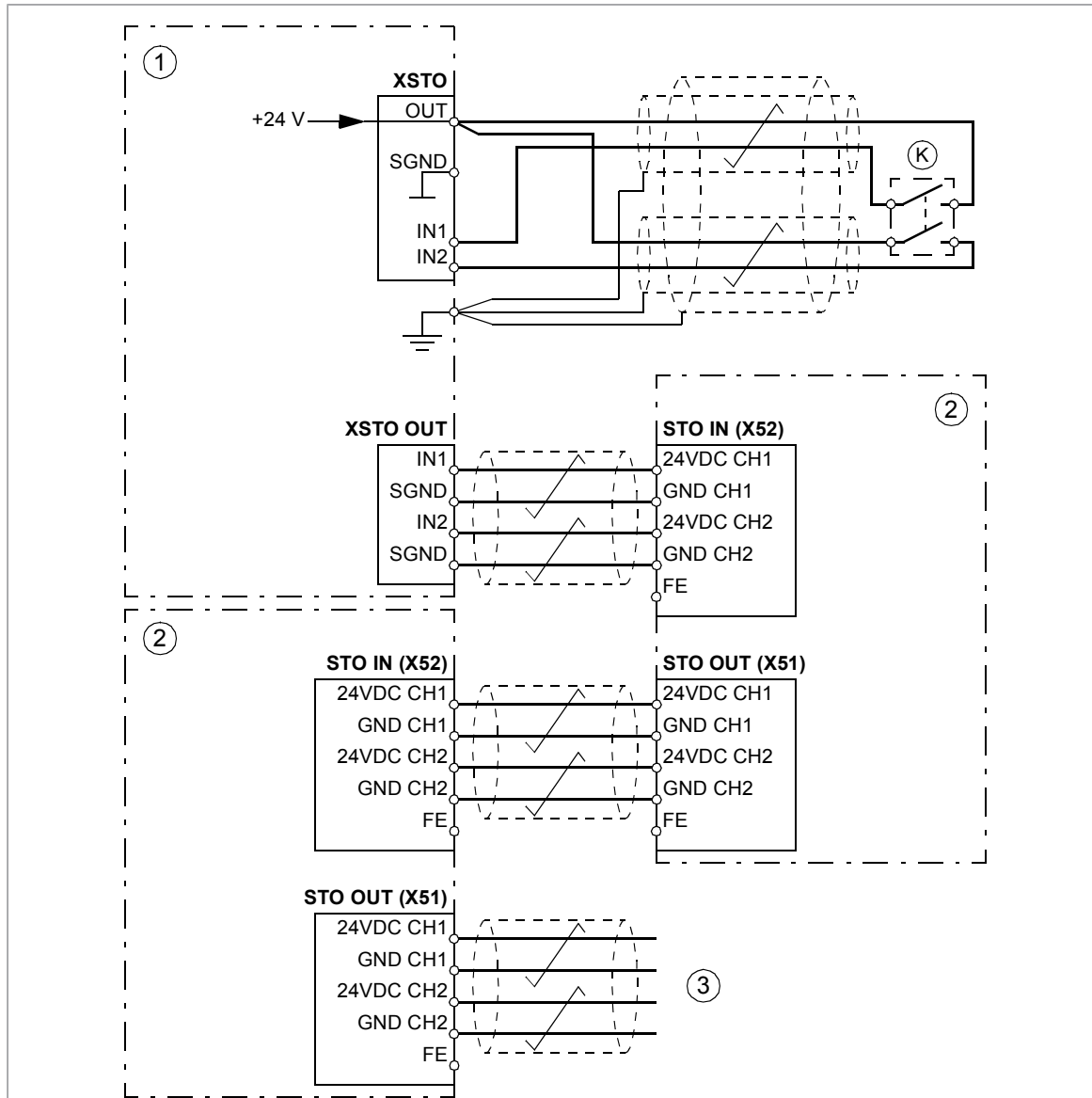

1	Inverter control unit
2	Inverter module(s)
3	To remaining inverter modules
K	Activation switch

Frame R8i and multiples with UCU-22...24 control unit

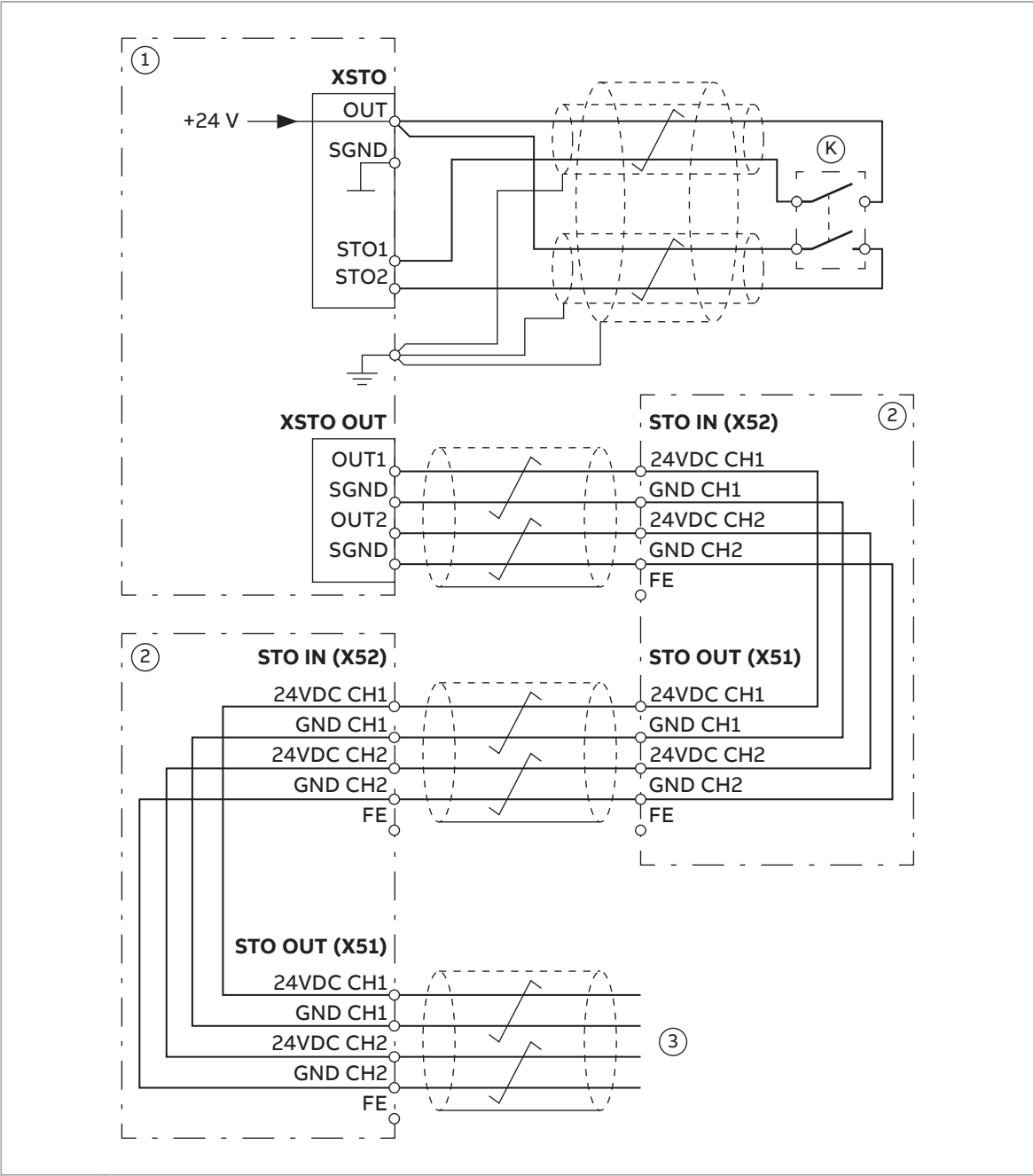

1	Inverter control unit
2	Inverter module(s)
3	To remaining inverter modules
K	Activation switch

■ **Single-channel connection of activation switch, with ZCU-12 control unit**

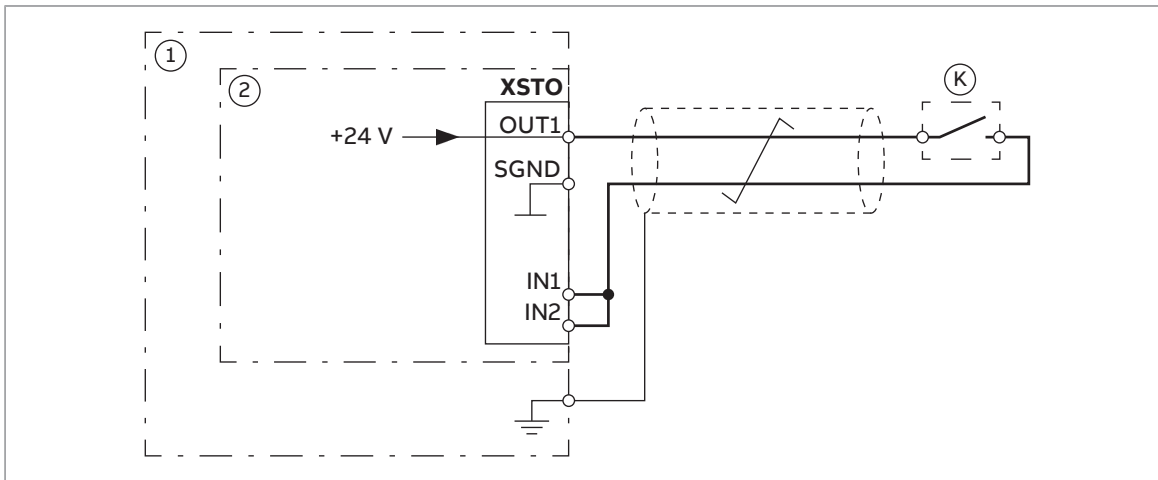

Note:

- Both STO inputs (IN1, IN2) must be connected to the activation switch. Otherwise, no SIL/PL classification is given.
- Pay special attention to avoiding any potential failure modes for the wiring. For example, use shielded cable. For measures for fault exclusion of wiring, see eg. EN ISO 13849-2:2012, table D.4.

1	Inverter unit
2	Control unit
K	Activation switch
	Note: A single-channel activation switch can limit the SIL/PL capability of the safety function to a lower level than the SIL/PL capability of the STO function of the drive.

■ **Single-channel connection of activation switch, with ZCU-14 or BCU control unit**

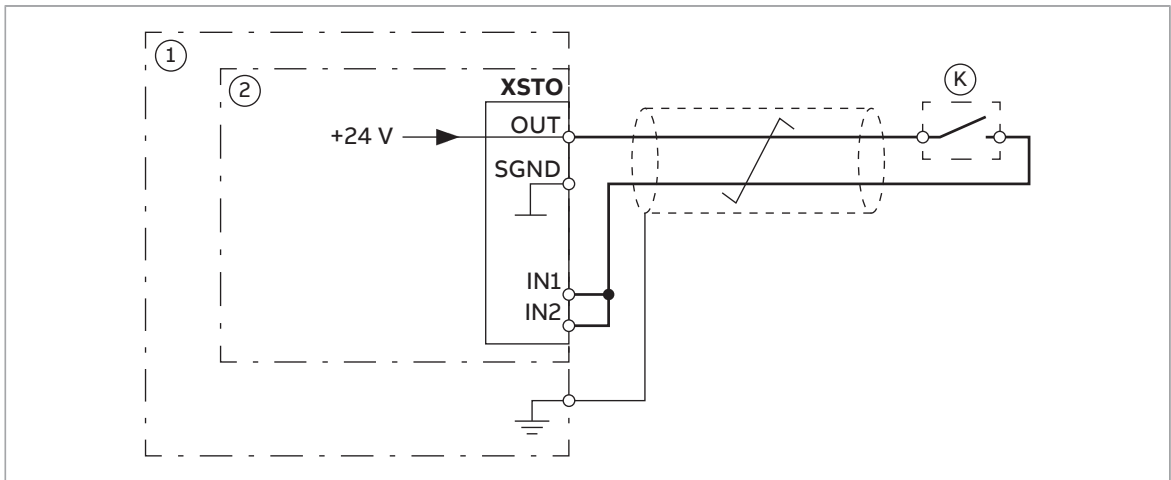

Note:

- Both STO inputs (IN1, IN2) must be connected to the activation switch. Otherwise, no SIL/PL classification is given.
- Pay special attention to avoiding any potential failure modes for the wiring. For example, use shielded cable. For measures for fault exclusion of wiring, see eg. EN ISO 13849-2:2012, table D.4.

1	Inverter unit
2	Control unit
K	Activation switch
	Note: A single-channel activation switch can limit the SIL/PL capability of the safety function to a lower level than the SIL/PL capability of the STO function of the drive.

■ **Single-channel connection of activation switch, with UCU-22...24 control unit**

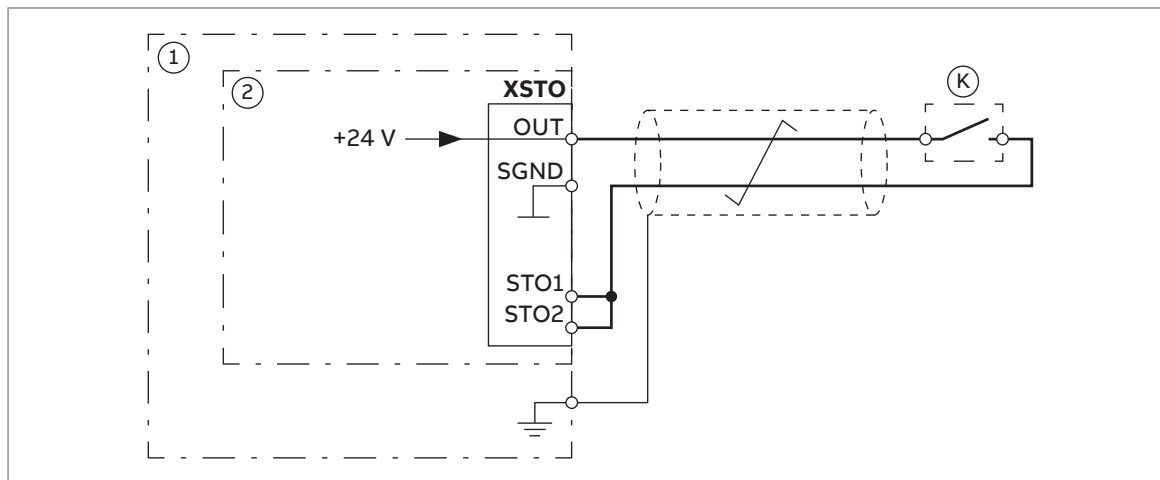

Note:

- Both STO inputs (STO1, STO2) must be connected to the activation switch. Otherwise, no SIL/PL classification is given.
- Pay special attention to avoiding any potential failure modes for the wiring. For example, use shielded cable. For measures for fault exclusion of wiring, see eg. EN ISO 13849-2:2012, table D.4.

1	Inverter unit
2	Control unit
K	Activation switch
	Note: A single-channel activation switch can limit the SIL/PL capability of the safety function to a lower level than the SIL/PL capability of the STO function of the drive.

■ Multiple inverter units

Internal power supply (example, inverter unit with ZCU or BCU control unit)

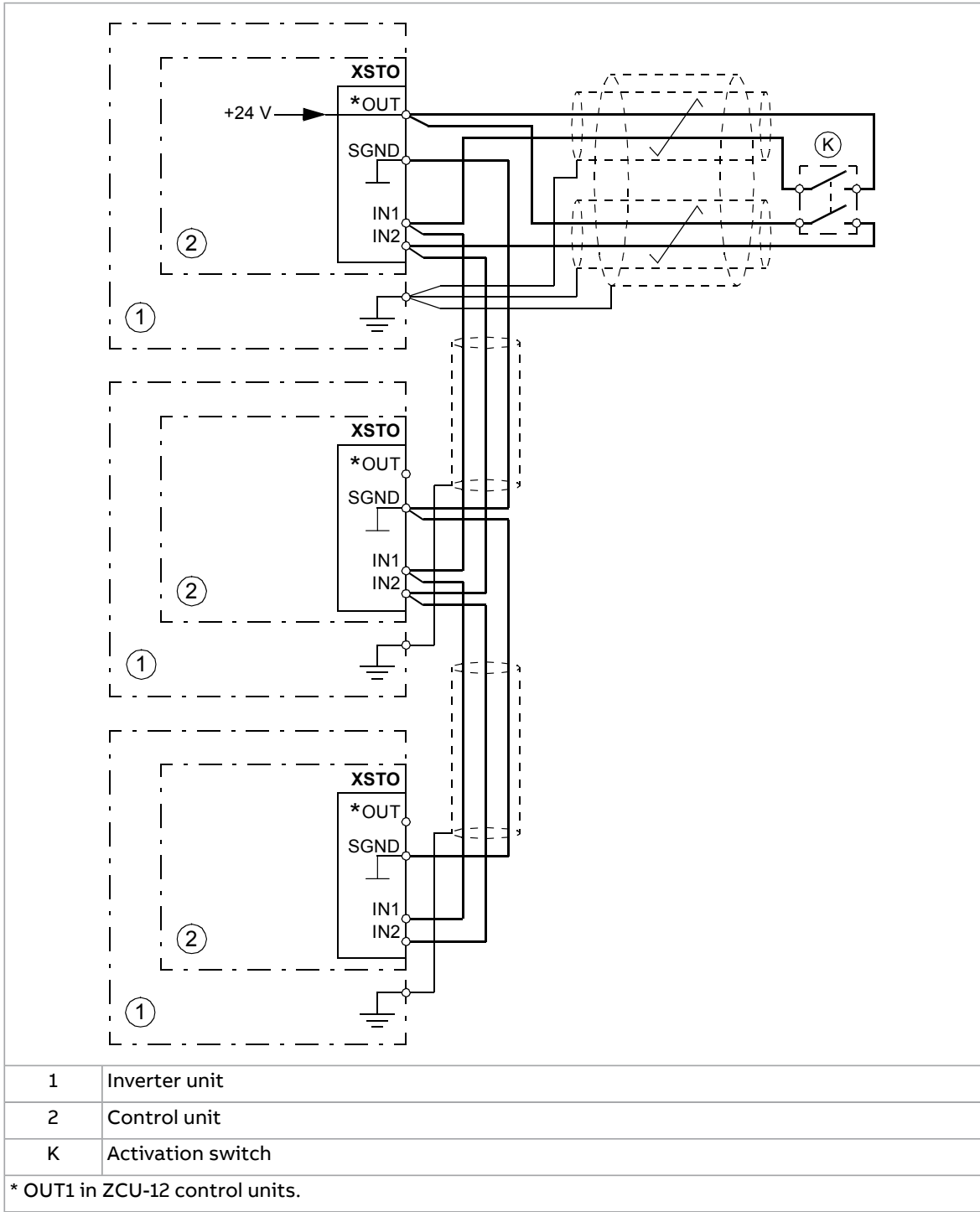

Internal power supply (example, inverter unit with UCU-22...24 control unit)

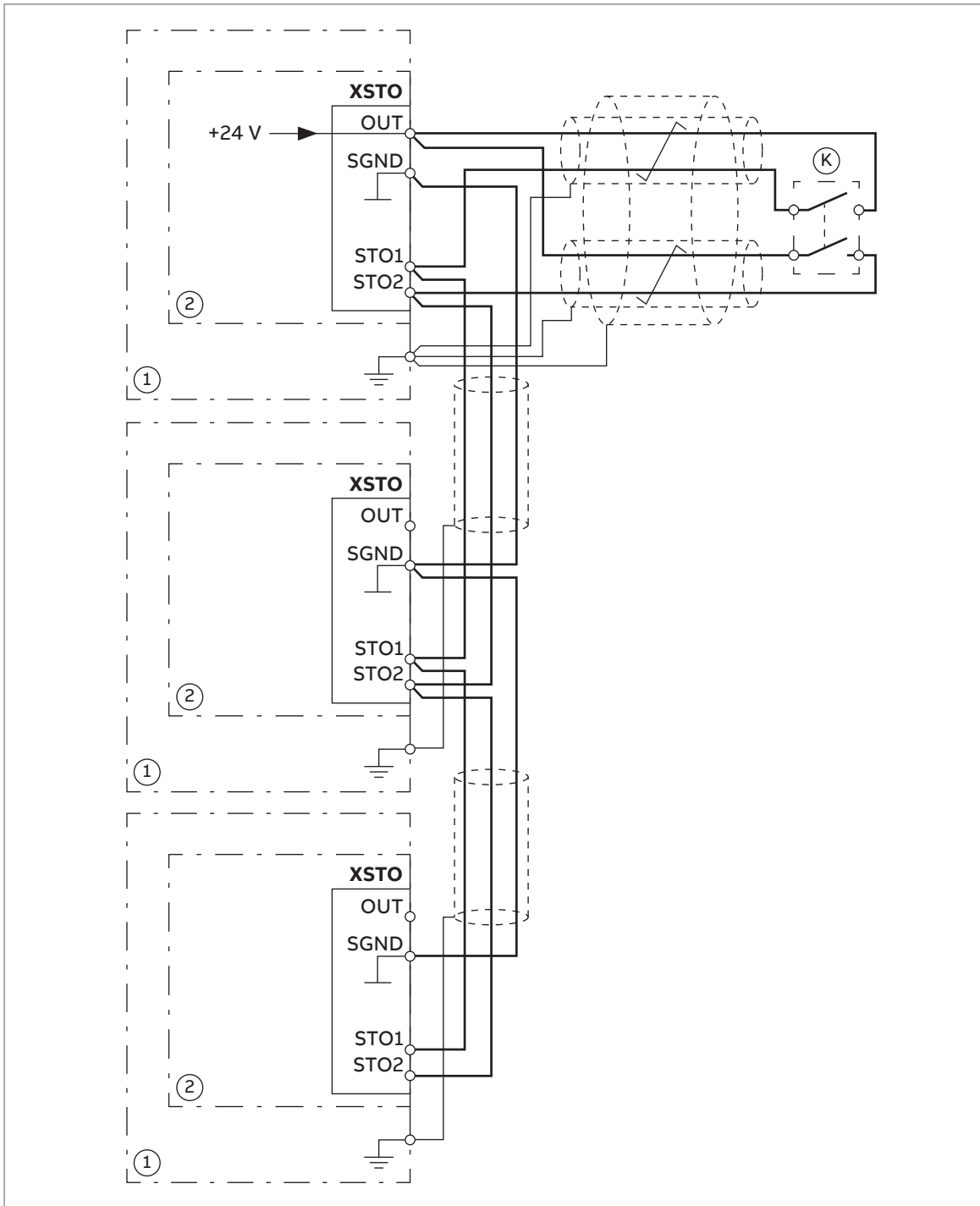

1	Inverter unit
2	Control unit
K	Activation switch

External power supply (example, inverter unit with ZCU or BCU control unit)

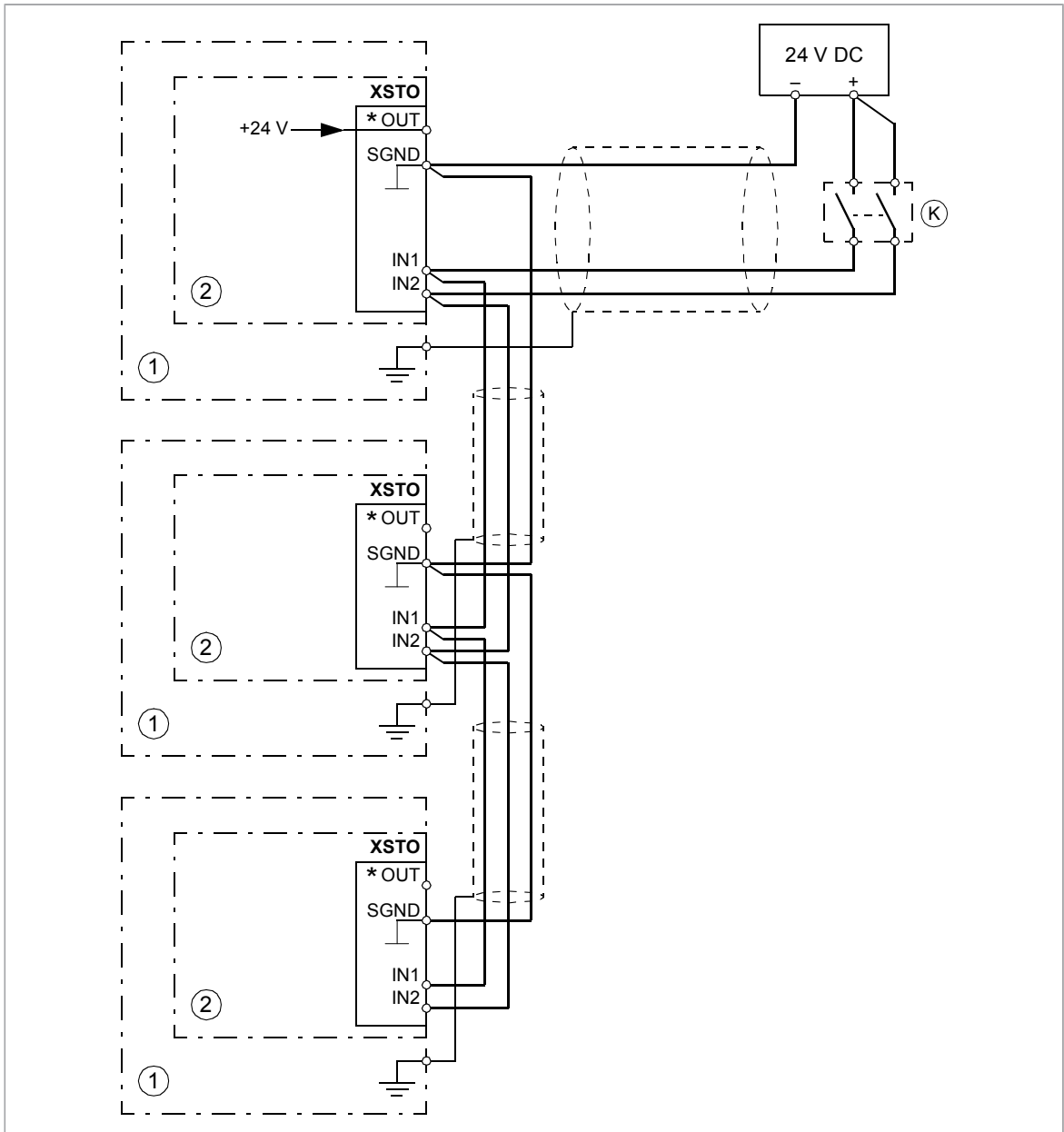

1	Inverter unit
2	Control unit
K	Activation switch
* OUT1 in ZCU-12 control units.	

External power supply (example, inverter unit with UCU-22...24 control unit)

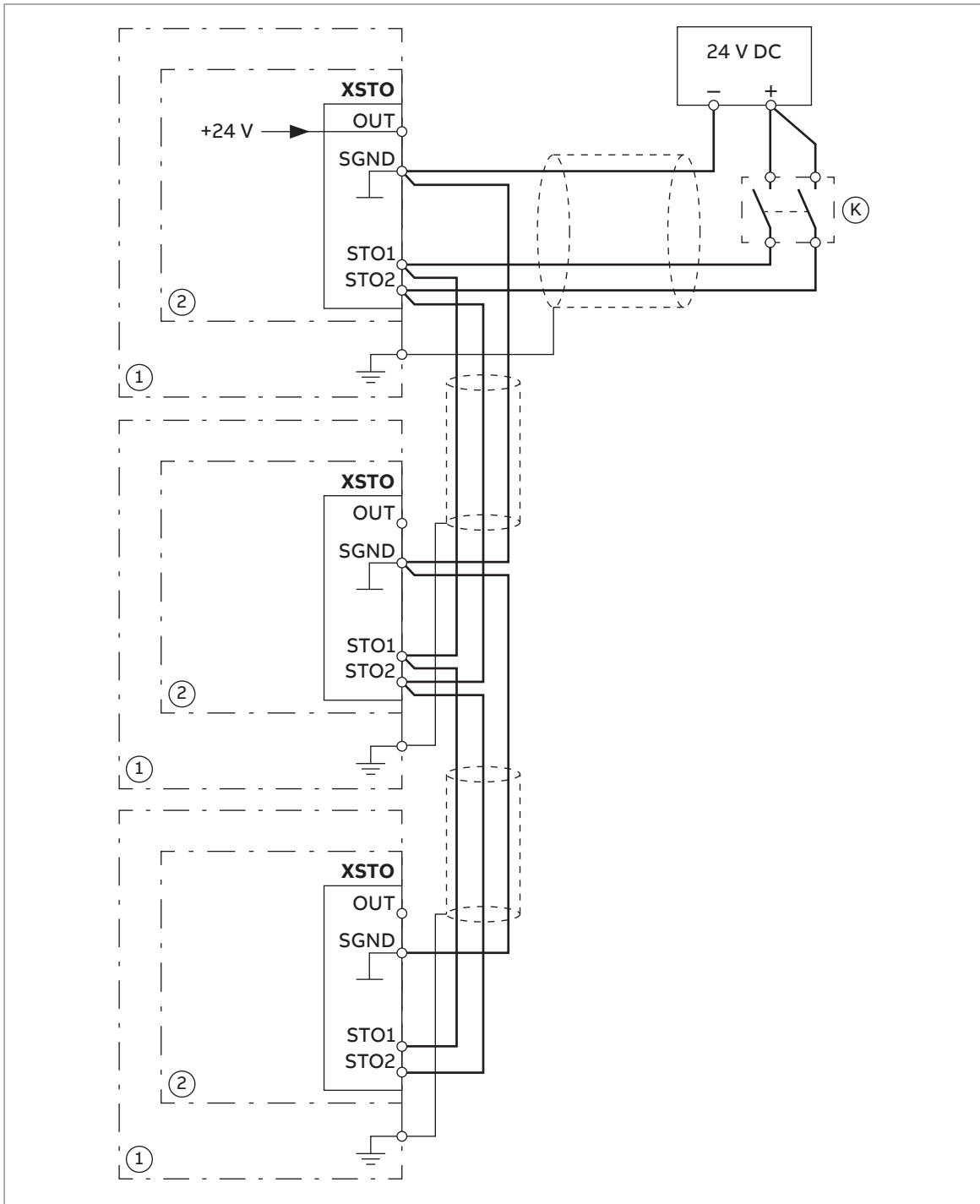

1	Inverter unit
2	Control unit
K	Activation switch

Operation principle

1. The Safe torque off activates (the activation switch is opened, or safety PLC logic output value is 0, or safety relay contacts open).
2. The STO inputs of the drive control unit de-energize.
3. The control unit cuts off the control voltage from the output IGBTs.
4. The control program generates an indication as defined by parameter 31.22 (refer to the firmware manual of the drive).
The parameter selects which indications are given when one or both STO signals are switched off or lost. The indications also depend on whether the drive is running or stopped when this occurs.

Note: This parameter does not affect the operation of the STO function itself. The STO function will operate regardless of the setting of this parameter: a running drive will stop upon removal of one or both STO signals, and will not start until both STO signals are restored and all faults reset.

Note: The loss of only one STO signal always generates a fault as it is interpreted as a malfunction of STO hardware or wiring.

5. The motor coasts to a stop (if running). The drive cannot restart while the activation switch or safety relay contacts are open. After the contacts close, a reset may be needed (depending on the setting of parameter 31.22). A new start command is required to start the drive.
-

Start-up including validation test

To ensure the safe operation of a safety function, validation is required. The final assembler of the machine must validate the function by performing a validation test. The test must be performed

1. at initial start-up of the safety function
2. after any changes related to the safety function (circuit boards, wiring, components, settings, replacement of inverter module, etc.)
3. after any maintenance work related to the safety function
4. after a drive firmware update
5. at the proof test of the safety function.

■ Competence

The validation test of the safety function must be carried out by a competent person with adequate expertise and knowledge of the safety function as well as functional safety, as required by IEC 61508-1 clause 6. The test procedures and report must be documented and signed by this person.

■ Validation test reports

Signed validation test reports must be stored in the logbook of the machine. The report shall include documentation of start-up activities and test results, references to failure reports and resolution of failures. Any new validation tests performed due to changes or maintenance shall be logged into the logbook.

■ Validation test procedure

After wiring the Safe torque off function, validate its operation as follows.

Note: If an FSO safety functions module, FSCS-21, FSPS-21 or FPTC module is installed, refer to its documentation.

Note: All inverter modules of the drive must be powered and connected to the STO circuit during the validation test.

Action	<input checked="" type="checkbox"/>
 ▲WARNING Obey the safety instructions. If you ignore them, injury or death, or damage to the equipment can occur.	<input type="checkbox"/>
Make sure that the motor can be run and stopped freely during start-up.	<input type="checkbox"/>
Stop the drive (if running), switch the input power off and isolate the drive from the power line using a disconnecter.	<input type="checkbox"/>
Check the STO circuit connections against the wiring diagram.	<input type="checkbox"/>
Close the disconnecter and switch the power on.	<input type="checkbox"/>
In case the drive consists of parallel-connected modules, check that the number of modules detected (parameter 95.14) matches the actual number of modules, and that the drive type is correctly set in parameter 95.31.	<input type="checkbox"/>

Action	<input checked="" type="checkbox"/>
<p>Test the operation of the STO function when the motor is stopped.</p> <ul style="list-style-type: none"> • Give a stop command for the drive (if running) and wait until the motor shaft is at a standstill. <p>Make sure that the drive operates as follows:</p> <ul style="list-style-type: none"> • Open the STO circuit. The drive generates an indication if one is defined for the 'stopped' state in parameter 31.22 (refer to the firmware manual). • Give a start command to verify that the STO function blocks the drive's operation. The motor should not start. • Close the STO circuit. • Reset any active faults. Restart the drive and check that the motor runs normally. 	<input type="checkbox"/>
<p>Test the operation of the STO function when the motor is running.</p> <ul style="list-style-type: none"> • Start the drive and make sure the motor is running. • Open the STO circuit. The motor should stop. The drive generates an indication if one is defined for the 'running' state in parameter 31.22 (refer to the firmware manual). • Reset any active faults and try to start the drive. • Make sure that the motor stays at a standstill and the drive operates as described above in testing the operation when the motor is stopped. • Close the STO circuit. • Reset any active faults. Restart the drive and check that the motor runs normally. 	<input type="checkbox"/>
<p>Test the operation of the failure detection of the drive. The motor can be stopped or running.</p> <ul style="list-style-type: none"> • Open the 1st input channel of the STO circuit. If the motor was running, it should coast to a stop. The drive generates an FA81 fault indication (refer to the firmware manual). • Give a start command to verify that the STO function blocks the drive's operation. The motor should not start. • Open the STO circuit (both channels). • Give a reset command. • Close the STO circuit (both channels). • Reset any active faults. Restart the drive and check that the motor runs normally. • Open the 2nd input channel of the STO circuit. If the motor was running, it should coast to a stop. The drive generates an FA82 fault indication (refer to the firmware manual). • Give a start command to verify that the STO function blocks the drive's operation. The motor should not start. • Open the STO circuit (both channels). • Give a reset command. • Close the STO circuit (both channels). • Reset any active faults. Restart the drive and check that the motor runs normally. 	<input type="checkbox"/>
<p>Document and sign the validation test report which verifies that the safety function is safe and accepted for operation.</p>	<input type="checkbox"/>

Use

1. Open the activation switch, or activate the safety functionality that is wired to the STO connection.
2. The STO inputs on the drive control unit de-energize, and the control unit cuts off the control voltage from the output IGBTs.
3. The control program generates an indication as defined by parameter 31.22 (refer to the firmware manual of the drive).
4. The motor coasts to a stop (if running). The drive will not restart while the activation switch or safety relay contacts are open.
5. Deactivate the STO by closing the activation switch, or resetting the safety functionality that is wired to the STO connection.
6. Reset any faults before restarting.



▲WARNING The Safe torque off function does not disconnect the voltage of the main and auxiliary circuits from the drive. Therefore maintenance work on electrical parts of the drive or the motor can only be carried out after isolating the drive from the supply and all other voltage sources.



▲WARNING The Safe torque off functionality is only achieved through the XSTO connector of the inverter control unit (A41). True Safe torque off functionality is not achieved through the XSTO connectors of other control units (such as the supply control unit or the brake control unit).

The Safe torque off function is supported by any ACS880 inverter or drive control program. It is not supported by supply, DC/DC converter or brake firmware.



▲WARNING The drive cannot detect or memorize any changes in the STO circuitry when the drive control unit is not powered or when the main power to the drive is off. If both STO circuits are closed and a level-type start signal is active when the power is restored, it is possible that the drive starts without a fresh start command. Take this into account in the risk assessment of the system.



▲WARNING Permanent magnet or synchronous reluctance [SynRM] motors only:

In case of a multiple IGBT power semiconductor failure, the drive can produce an alignment torque which maximally rotates the motor shaft by $180/p$ degrees (with permanent magnet motors) or $180/2p$ degrees (with synchronous reluctance [SynRM] motors) regardless of the activation of the Safe torque off function. p denotes the number of pole pairs.

Notes:

- If a running drive is stopped by using the Safe torque off function, the drive will cut off the motor supply voltage and the motor will coast to a stop. If this causes

danger or is not otherwise acceptable, stop the drive and machinery using the appropriate stop mode before activating the Safe torque off function.

- The Safe torque off function overrides all other functions of the drive.
 - The Safe torque off function is ineffective against deliberate sabotage or misuse.
 - The Safe torque off function has been designed to reduce the recognized hazardous conditions. In spite of this, it is not always possible to eliminate all potential hazards. The assembler of the machine must inform the final user about the residual risks.
-

Maintenance

After the operation of the circuit is validated at start-up, the STO function shall be maintained by periodic proof testing. In high demand mode of operation, the maximum proof test interval is 20 years. In low demand mode of operation, the maximum proof test interval is 10 years: Refer to [Safety data \(page 411\)](#).

There are two alternative procedures for proof testing:

1. Perfect proof testing. It is assumed that all dangerous failures of the STO circuit are detected during the test. PFD_{avg} values for STO with the perfect proof testing procedure are given in the safety data section.
2. Simplified proof testing. This procedure is faster and simpler than perfect proof testing. Not all dangerous failures of the STO circuit are detected during the test. The PFD_{avg} value for STO with the simplified proof testing procedure is given in the safety data section.

Note: The proof testing procedures are only valid for proof testing (periodic test, item 5 under section [Start-up including validation test](#)) but not for re-validation after changes made in the circuit. Re-validation (items 1...4 under [Start-up including validation test](#)) must be done according to the initial validation procedure.

Note: Refer also to the Recommendation of Use CNB/M/11.050 (published by the European co-ordination of Notified Bodies) concerning dual-channel safety-related systems with electromechanical outputs:

- When the safety integrity requirement for the safety function is SIL 3 or PL e (cat. 3 or 4), the proof test for the function must be performed at least every month.
- When the safety integrity requirement for the safety function is SIL 2 (HFT = 1) or PL d (cat. 3), the proof test for the function must be performed at least every 12 months.

The STO function of the drive does not contain any electromechanical components.

In addition to proof testing, it is a good practice to check the operation of the function when other maintenance procedures are carried out on the machinery.

Include the Safe torque off operation test described above in the routine maintenance program of the machinery that the drive runs.

If any wiring or component change is needed after start-up, or the parameters are restored, do the test given in [Validation test procedure \(page 404\)](#).

Use only spare parts approved by ABB.

Record all maintenance and proof test activities in the machine logbook.

■ Competence

The maintenance and proof test activities of the safety function must be carried out by a competent person with adequate expertise and knowledge of the safety function as well as functional safety, as required by IEC 61508-1 clause 6.

■ Perfect proof test procedure

Action	<input checked="" type="checkbox"/>
 WARNING Obey the safety instructions. If you ignore them, injury or death, or damage to the equipment can occur.	<input type="checkbox"/>
<p>Test the operation of the STO function. If the motor is running, it will stop during the test.</p> <ul style="list-style-type: none"> • Give a stop command for the drive (if running) and wait until the motor shaft is at a standstill. <p>Make sure that the drive operates as follows:</p> <ul style="list-style-type: none"> • Open the STO circuit. The drive generates an indication if one is defined for the 'stopped' state in parameter 31.22 (see the firmware manual). • Close the STO circuit. • Reset any active faults. Restart the drive and check that the motor runs normally. 	<input type="checkbox"/>
<p>Test the operation of the failure detection of the drive. The motor can be stopped or running.</p> <ul style="list-style-type: none"> • Open the 1st input channel of the STO circuit. If the motor was running, it should coast to a stop. The drive generates an FA81 fault indication (see the firmware manual). • Open the STO circuit (both channels). • Give a reset command. • Close the STO circuit (both channels). • Reset any active faults. • Open the 2nd input channel of the STO circuit. If the motor was running, it should coast to a stop. The drive generates an FA82 fault indication (see the firmware manual). • Open the STO circuit (both channels). • Give a reset command. • Close the STO circuit (both channels). • Reset any active faults. Restart the drive and check that the motor runs normally. 	<input type="checkbox"/>
Document and sign the test report to verify that the safety function has been tested according to the procedure.	<input type="checkbox"/>

■ Simplified proof test procedure

Action	<input checked="" type="checkbox"/>
 WARNING Obey the safety instructions. If you ignore them, injury or death, or damage to the equipment can occur.	<input type="checkbox"/>
<p>Test the operation of the STO function. If the motor is running, it will stop during the test.</p> <ul style="list-style-type: none"> • Give a stop command for the drive (if running) and wait until the motor shaft is at a standstill. <p>Make sure that the drive operates as follows:</p> <ul style="list-style-type: none"> • Open the STO circuit. The drive generates an indication if one is defined for the 'stopped' state in parameter 31.22 (see the firmware manual). • Close the STO circuit. • Reset any active faults. Restart the drive and check that the motor runs normally. 	<input type="checkbox"/>
Document and sign the test report to verify that the safety function has been tested according to the procedure.	<input type="checkbox"/>

Fault tracing

The indications given during the normal operation of the Safe torque off function are selected by drive control program parameter 31.22.

The diagnostics of the Safe torque off function cross-compare the status of the two STO channels. In case the channels are not in the same state, a fault reaction function is performed and the drive trips on an FA81 or FA82 fault. An attempt to use the STO in a non-redundant manner, for example activating only one channel, will trigger the same reaction.

Refer to the firmware manual of the drive control program for the indications generated by the drive, and for details on directing fault and warning indications to an output on the control unit for external diagnostics.

Any failures of the Safe torque off function must be reported to ABB.

Safety data

The safety data for the Safe torque off function is given below.

Note: The safety data is calculated for redundant use, and applies only if both STO channels are used.

Frame size	SIL	SC	PL	PFH ($T_1 = 20$ a) (1/h)	PFD _{avg}		DC SFF (%)	Cat.	HFT	CCF	T_M (a)	PFH _{diag} (1/h)	$\lambda_{Diag,s}$ (1/h)	$\lambda_{Diag,d}$ (1/h)
					Perfect proof test $T_1 = 5$ a	Simplified proof test $T_1 = 5$ or 10 a								
R1i														
R2i	3	3	e	4.36E-10	9.56E-06	1.91E-05	3.82E-05	3	1	80	20	6.04E-09	1.34E-07	1.08E-08
R3i														
R4i														
R5i	3	3	e	3.92E-10	8.35E-06	1.68E-05	3.40E-05	3	1	80	20	6.04E-09	1.83E-07	1.08E-08
R6i														
R7i	3	3	e	5.28E-10	1.10E-05	2.22E-05	4.54E-05	3	1	80	20	6.12E-09	2.30E-07	2.27E-07
R8i	3	3	e	5.82E-10	1.25E-05	2.51E-05	5.06E-05	3	1	80	20	5.35E-09	3.32E-07	2.86E-07
2×R8i	3	3	e	5.92E-10	1.27E-05	2.55E-05	5.15E-05	3	1	80	20	6.13E-09	4.50E-07	3.65E-07
3×R8i	3	3	e	6.02E-10	1.29E-05	2.59E-05	5.23E-05	3	1	80	20	6.92E-09	5.67E-07	4.43E-07
4×R8i	3	3	e	6.11E-10	1.31E-05	2.63E-05	5.31E-05	3	1	80	20	7.71E-09	6.85E-07	5.22E-07
5×R8i	3	3	e	6.21E-10	1.33E-05	2.68E-05	5.39E-05	3	1	80	20	8.50E-09	8.02E-07	6.01E-07
6×R8i	3	3	e	6.30E-10	1.35E-05	2.72E-05	5.48E-05	3	1	80	20	9.29E-09	9.19E-07	6.80E-07
7×R8i	3	3	e	6.40E-10	1.37E-05	2.76E-05	5.56E-05	3	1	80	20	1.01E-08	1.04E-06	7.58E-07
8×R8i	3	3	e	6.49E-10	1.39E-05	2.80E-05	5.64E-05	3	1	80	20	1.09E-08	1.15E-06	8.37E-07
9×R8i	3	3	e	6.59E-10	1.42E-05	2.84E-05	5.73E-05	3	1	80	20	1.16E-08	1.27E-06	9.16E-07
10×R8i	3	3	e	6.69E-10	1.44E-05	2.88E-05	5.81E-05	3	1	80	20	1.24E-08	1.39E-06	9.95E-07

3AXD10000041323 L, 3AXD10000078136 K, 3AXD10001716945 D, 3AXD10001916430 D

- The STO is a type A safety component as defined in IEC 61508-2.
- Relevant failure modes:
 - The STO trips spuriously (safe failure)
 - The STO does not activate when requested
 - A fault exclusion on the failure mode “short circuit on printed circuit board” has been made (EN 13849-2, table D.5). The analysis is based on an assumption that one failure occurs at one time. No accumulated failures have been analyzed.
- STO response times:
 - STO reaction time (shortest detectable break): 1 ms
 - STO response time:
 - Frames R1i...R7i: 7 ms (typical), 10 ms (maximum)
 - Frame R8i and multiples: 2 ms (typical), 25 ms (maximum)
 - Fault detection time: Channels in different states for longer than 200 ms
 - Fault reaction time: Fault detection time + 10 ms.
- Indication delays:
 - STO fault indication (parameter 31.22) delay: < 500 ms
 - STO warning indication (parameter 31.22) delay: < 1000 ms.

■ Terms and abbreviations

Term or abbreviation	Reference	Description
Cat.	EN ISO 13849-1	Classification of the safety-related parts of a control system in respect of their resistance to faults and their subsequent behavior in the fault condition, and which is achieved by the structural arrangement of the parts, fault detection and/or by their reliability. The categories are: B, 1, 2, 3 and 4.
CCF	EN ISO 13849-1	Common cause failure (%)
DC	EN ISO 13849-1	Diagnostic coverage (%)
HFT	IEC 61508	Hardware fault tolerance
MTTF _D	EN ISO 13849-1	Mean time to dangerous failure: (Total number of life units) / (Number of dangerous, undetected failures) during a particular measurement interval under stated conditions
PFD _{avg}	IEC 61508	Average probability of dangerous failure on demand, that is, mean unavailability of a safety-related system to perform the specified safety function when a demand occurs
PFH	IEC 61508	Average frequency of dangerous failures per hour, that is, average frequency of a dangerous failure of a safety related system to perform the specified safety function over a given period of time
PFH _{diag}	IEC/EN 62061	Average frequency of dangerous failures per hour for the diagnostic function of STO
PL	EN ISO 13849-1	Performance level. Levels a...e correspond to SIL
Proof test	IEC 61508, IEC 62061	Periodic test performed to detect failures in a safety-related system so that, if necessary, a repair can restore the system to an "as new" condition or as close as practical to this condition
SC	IEC 61508	Systematic capability (1...3)
SFF	IEC 61508	Safe failure fraction (%)
SIL	IEC 61508	Safety integrity level (1...3)
STO	IEC/EN 61800-5-2	Safe torque off

Term or abbreviation	Reference	Description
T_1	IEC 61508-6	Proof test interval. T_1 is a parameter used to define the probabilistic failure rate (PFH or PFD) for the safety function or subsystem. Performing a proof test at a maximum interval of T_1 is required to keep the SIL capability valid. The same interval must be followed to keep the PL capability (EN ISO 13849) valid. Refer also section Maintenance.
T_M	EN ISO 13849-1	Mission time: the period of time covering the intended use of the safety function/device. After the mission time elapses, the safety device must be replaced. Note that any T_M values given cannot be regarded as a guarantee or warranty.
λ_{Diag_d}	IEC 61508-6	Dangerous failure rate (per hour) of the diagnostics function of STO
λ_{Diag_s}	IEC 61508-6	Safe failure rate (per hour) of the diagnostics function of STO

■ TÜV certificate

The TÜV certificate is available on the Internet.



14

Resistor braking using frames R1i...R4i inverter modules

Contents of this chapter

This chapter deals with using the internal brake choppers of frame R1i...R4i inverter modules.

Using R1i...R4i modules for resistor braking

The internal brake choppers of frame R1i...R4i inverter modules can be used for resistor braking of other modules. Brake resistors are available from ABB as add-on kits and must be installed in separate cubicles; contact your local ABB representative for details.

Planning the braking system

- The continuous and maximum braking power ratings of individual inverter modules are listed on [Ratings \(page 421\)](#) .

The total continuous braking power of parallel-connected modules is calculated with the formula

$$P_{brcont} = P_{brcont1} + 0.8 \times (P_{brcont2} + P_{brcont3} + \dots)$$

where $P_{brcont1}$, $P_{brcont2}$, etc. are the P_{brcont} values of the connected modules from largest to smallest.

The total maximum braking power of parallel-connected modules is calculated with the formula

$$P_{brmax} = P_{brmax1} + 0.7 \times (P_{brmax2} + P_{brmax3} + \dots)$$

where P_{brmax1} , P_{brmax2} , etc. are the P_{brmax} values of the connected modules from largest to smallest.

- The resistance of the resistor must not be lower than R_{min} . The energy transferred by any inverter module to its resistor must not exceed the heat dissipation capacity (E_R) of the resistor.

■ Restrictions

- Internal brake choppers are only available for frame R1i...R4i, ACS880-104-xxxxx-3 and ACS880-104-xxxxx-5 inverter module types.
- The maximum number of modules doing the braking is 12 frame R1i...R2i modules or 6 frame R3i...R4i modules, ie. the number of modules that can be mounted into a 800 mm wide Rittal TS 8 cubicle.
- Each inverter module must have its own resistor(s).
- In case the braking power of the modules is not sufficient, a separate brake chopper must be used. It is not allowed to use the internal brake choppers simultaneously with a separate brake chopper.
- The cubicle with the braking modules must be next in the line-up to the inverter that needs to be braked.
- The internal brake choppers cannot be used if the system has an IGBT (regenerative) supply unit.

■ Selecting the brake resistor

[Ratings \(page 421\)](#) lists an example brake resistor for each inverter type. These resistors are available from ABB.

When sourcing a resistor from a third party, make sure that:

1. The resistance of the custom resistor is greater or equal than the minimum allowed resistance:

$$R \geq R_{min}$$

where

R Resistance of the custom resistor.



▲ WARNING Never use a brake resistor with a resistance smaller than R_{min} . The inverter module and the chopper are not able to handle the overcurrent caused by the low resistance.

R_{min} Minimum allowed resistance of the brake resistor. See section Ratings.

2. The load capacity of the custom resistor is higher than the instantaneous maximum power consumption of the resistor when it is connected to the DC link voltage by the chopper:

$$P_r > \frac{U_{DC}^2}{R}$$

where

P_r Load capacity of the custom resistor

U_{DC}	Drive DC link voltage. 1.35 · 1.25 · 415 V DC (when supply voltage is 380 to 415 V AC) or 1.35 · 1.25 · 500 V DC (when supply voltage is 440 to 500 V AC)
R	Resistance of the custom resistor

■ Selecting and routing the brake resistor cables

Use the same cable type for resistor as for inverter input cabling to ensure that the inverter DC fuses also protect the resistor cable.

Minimizing electromagnetic interference

Make sure that the installation complies with the EMC requirements. Obey these rules to minimize electromagnetic interference caused by the rapid voltage and current changes in the resistor cables:

- Shield the brake resistor cable. Use shielded cable or a metallic enclosure. If you use unshielded single-core cables, route them inside a cabinet that efficiently suppresses the radiated emissions.
- Install the cables away from other cable routes.
- Avoid long parallel runs with other cables. The minimum parallel cabling separation distance is 0.3 meters (1 ft).
- Cross the other cables at 90° angles.
- Keep the cable as short as possible to minimize the radiated emissions and stress on the brake chopper. A longer cable produces more radiated emissions, inductive load, and voltage peaks over the IGBT semiconductors of the brake chopper.

Maximum cable length

The maximum cable length of the resistor cable is 10 m (33 ft).

■ Selecting the installation location for the brake resistors

Protect the open (IP00) brake resistors against contact. Install the brake resistor in a place where it cools effectively. Arrange the cooling of the resistor so that:

- no danger of overheating is caused to the resistor or nearby materials, and
- the temperature of the space that the resistor is in does not go above the allowed maximum value.



▲WARNING The materials near the brake resistor must be non-flammable. The surface temperature of the resistor is high. Air flowing from the resistor is of hundreds of degrees Celsius. If the exhaust vents are connected to a ventilation system, make sure that the material withstands high temperatures. Protect the resistor against contact.

■ Protecting the system against thermal overload

The inverter module protects itself and the resistor cable against thermal overload when the cable is correctly dimensioned. The inverter control program includes a resistor and resistor cable thermal protection function which can be tuned by the user. See the firmware manual.

Equipping the drive system with a main contactor or breaker is highly recommended for safety reasons. Wire the contactor or breaker so that it opens in case the resistor overheats. This is essential for safety since the inverter module may not be able to break the current if the chopper remains conductive in a fault situation. An example wiring diagram is shown below. ABB resistors are equipped with a thermal switch (5) inside the resistor assembly as standard. The switch indicates overtemperature and overload.

We recommend that you also wire the thermal switch to a digital input of the inverter module.

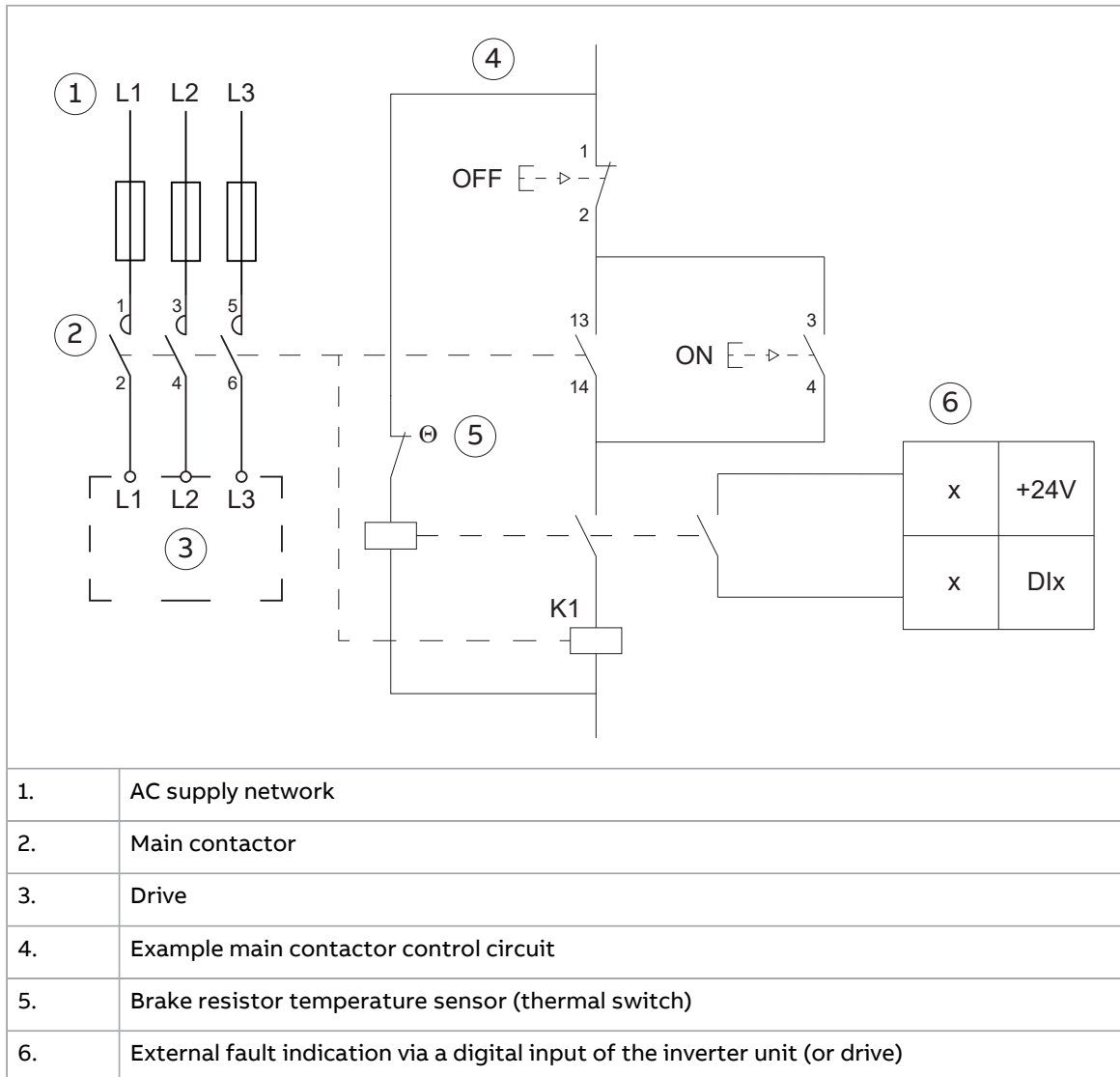

■ Protecting the resistor cable against short circuit

The DC fuses of the inverter module will also protect the resistor cable if the cable is identical with the inverter input cable.

Mechanical installation

All brake resistors must be installed outside the drive. Follow the resistor manufacturer's instructions.

Electrical installation

■ Checking the insulation of the brake resistor assembly

Check the insulation of each brake resistor assembly as follows:

1. Check that the resistor cable is connected to the resistor, and disconnected from the inverter module terminals R+ and R-.
2. At the inverter end, connect the R+ and R- conductors of the resistor cable together. Measure the insulation resistance between the combined conductors and the Protective Earth (PE) conductor by using a measuring voltage of 1000 V DC. The insulation resistance must be higher than 1 Mohm.

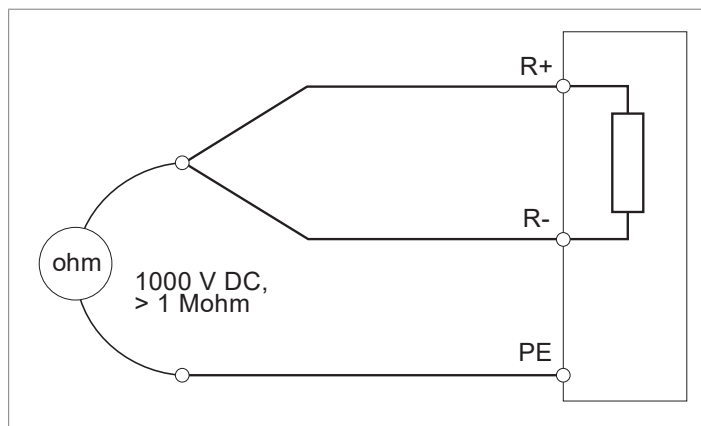

■ Connection procedure

1. Connect the resistor cable to the R+ and R- terminals in the same way as the other power cables. Use the same cable type as with the DC input cable. If a shielded threeconductor cable is used, cut the third conductor, insulate it, and ground the twisted shield of the cable (protective earth conductor of the resistor assembly) at both ends.
2. Connect the thermal switch of the brake resistor as described above under [Protecting the system against thermal overload](#).

Start-up

Note: New brake resistors may be coated with storage grease. As the brake chopper operates for the first time, the grease burns off and may produce some smoke. Make sure there is proper ventilation.

Set the following inverter control program parameters (ACS880 primary control program) in each braking inverter:

- Disable the overvoltage control (parameter 30.30).
- Set parameter 31.01 to point to the digital input to which the thermal switch of the brake resistor is wired.
- Set parameter 31.02 so that the event generates a fault.
- Enable the brake chopper by parameter 43.06 Brake chopper enable. If you select Enabled with thermal model, also set the brake resistor overload protection parameters 43.08 and 43.09 according to the application.
- Check the value of parameter 43.10 Brake resistance.
- Adjust other brake-related settings as necessary in parameter group 43. Match the brake chopper operating limits of all braking inverters. You will need to enter a service-level pass code into parameter 96.02 to access the limit parameters. To obtain the pass code, contact your local ABB representative.
 - Stop all inverters of the drive system (even those not used for braking) if any are running.
 - Monitor the DC voltage (parameter 01.11) on each braking inverter for a period of time. Calculate the average of the readings separately for each inverter.
 - Select one braking inverter as reference. On this inverter, enter the nominal AC supply voltage into parameter 95.37. Multiply this value by the number shown in the table below to get the value of 95.36.

Supply voltage range [V AC] (see parameter 95.01)				
	208...240	380...415	440...480	500
[95.36] = [95.37] ×	0.867	0.916	0.917	1.000

For example, with a 380...415 V inverter, the value of 95.36 should be 0.916 times the value of 95.37.

- For each of the remaining braking inverters, divide the average DC voltage value of the inverter by that of the reference inverter. Multiply the result with the nominal supply voltage, and enter the result into parameter 95.37. Further multiply the value of 95.37 by the factor shown in the above table to get the value of 95.36.
- On all braking inverters, enable custom supply voltage limits using parameter 95.35.

With these parameter settings, a resistor overtemperature situation will trip the inverter which will then coast to a stop.



▲ WARNING Connect the brake resistor to the inverter module before enabling the brake chopper. On the other hand, if the chopper is disabled, the resistor must be disconnected.

For settings with other control programs, see the appropriate firmware manual.

Technical data

■ Ratings

ACS880-104-....	Output ratings			Brake resistor example			
	P_{brcont}	P_{brmax}	R_{min}	Type	R	P_n	E_R
	kW	kW	ohm		ohm	W	kJ
$U_n = 400\text{ V}$							
004A8-3	1.8	3.3	120	JBR-01 (Danotherm CAR 155 D T 414 120R)	120	105	22
006A0-3	1.9	3.3	120				
008A0-3	1.9	3.3	120				
0011A-3	2.8	50	80	JBR-03 (Danotherm CAR 200 D T 415 80R)	80	135	40
0014A-3	5.7	10.0	40	JBR-04 (Danotherm CBR-V 210 D T 415 40R)	40	360	73
0018A-3	5.7	10.00	40				
0025A-3	11.4	20.0	20	JBR-05 (Danotherm CBR-V 330 D T 415 20R)	20	570	77
0035A-3	11.4	20.0	20				
0044A-3	17.5	30.8	13	JBR-06 (Danotherm CBR-V 460 D HT 415 13R)	13	790	132
0050A-3	17.5	30.8	13				
0061A-3	17.5	30.8	13				
0078A-3	17.5	30.8	13				
0094A-3	17.5	30.8	13				
0100A-3	17.5	30.8	13				
$U_n = 500\text{ V}$							
003A6-5	1.3	5.5	120	JBR-01 (Danotherm CAR 155 D T 414 120R)	120	105	22
004A8-5	1.8	5.5	120				
006A0-5	1.9	5.5	120				
008A0-5	1.9	5.5	120				
0011A-5	2.8	7.9	80	JBR-03 (Danotherm CAR 200 D T 415 80R)	80	135	40
0014A-5	5.7	14.6	40	JBR-04 (Danotherm CBR-V 210 D T 415 40R)	40	360	73
0018A-5	5.7	14.6	40				
0025A-5	11.4	30.7	20	JBR-05 (Danotherm CBR-V 330 D T 415 20R)	20	570	77
0030A-5	11.4	30.7	20				
0035A-5	11.4	30.7	20				
0050A-5	17.5	43.9	13	JBR-06 (Danotherm CBR-V 460 D HT 415 13R)	13	790	132
0061A-5	17.5	43.9	13				
0078A-5	17.5	43.9	13				
0094A-5	17.5	43.9	13				

Definitions

P_{brcont}	Maximum continuous braking power. The braking is considered continuous if the braking time exceeds 30 seconds.
P_{brmax}	Maximum braking power of the inverter module and its internal brake chopper. The inverter and chopper will withstand this braking power for 1 second within every 10 seconds. Note: The listed resistors will withstand this braking power for 1 second within every 120 seconds.
R_{min}	Minimum allowed resistance of the brake resistor.
R	Resistance of the listed resistor.
P_n	Continuous power (heat) dissipation of the listed resistor when placed correctly.
E_R	Short energy pulse that the listed resistor will withstand every 400 seconds.

The ratings apply at an ambient temperature of 40 °C (104 °F).

The listed brake resistors are protected to IP20. Refer to [Resistor dimensions \(page 423\)](#) for dimensions, wire sizes and tightening torques for the resistors.

■ Resistor dimensions

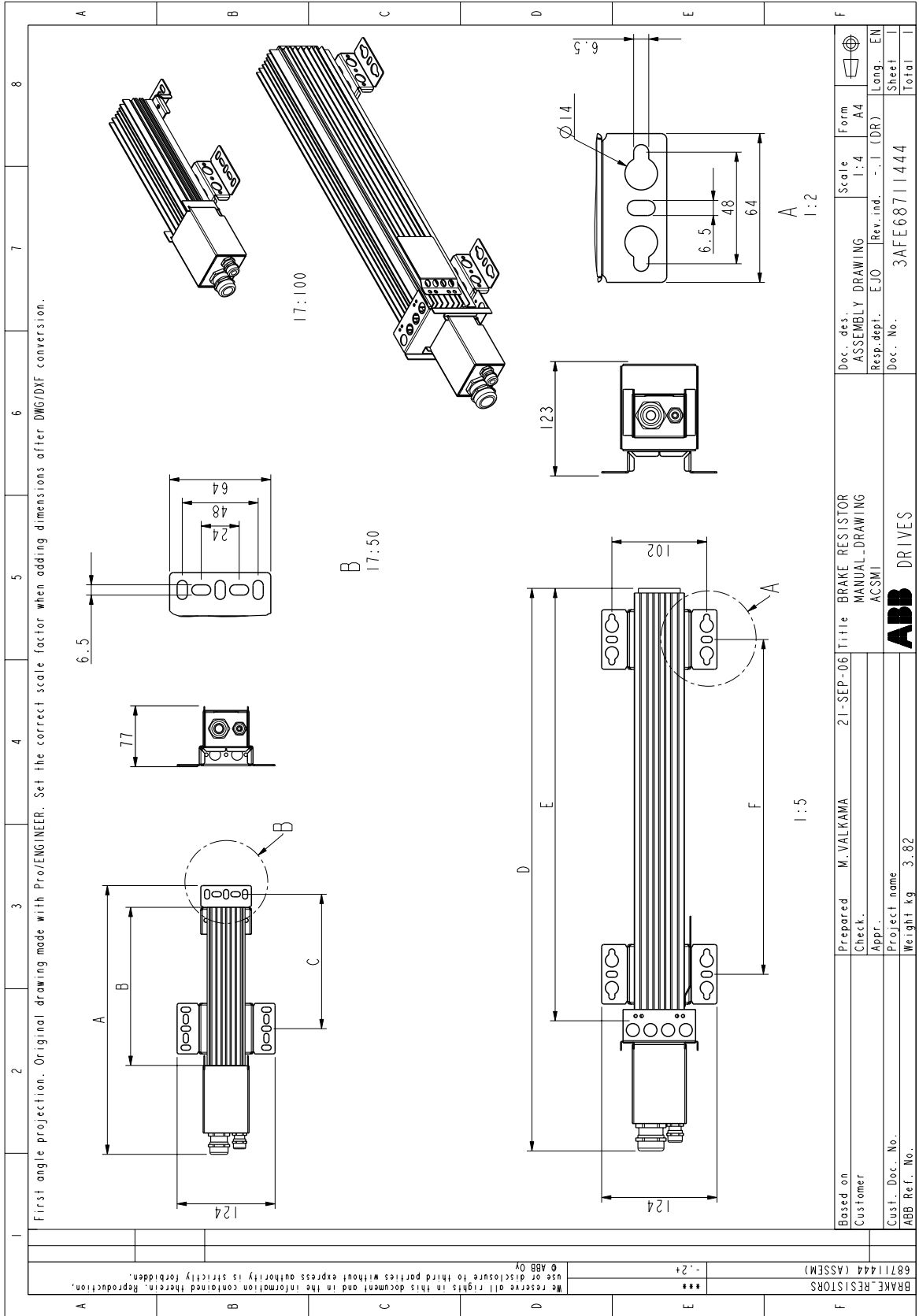

424 Resistor braking using frames R1i...R4i inverter modules

Dimension	Resistor type				
	JBR-01	JBR-03	JBR-04	JBR-05	JBR-06
A mm (in)	295 (11.61)	340 (13.39)	–	–	–
B mm (in)	155 (6.10)	200 (7.87)	–	–	–
C mm (in)	125 (4.92)	170 (6.69)	–	–	–
D mm (in)	–	–	345 (13.58)	465 (18.31)	595 (23.43)
E mm (in)	–	–	210 (8.27)	330 (12.99)	460 (18.11)
F mm (in)	–	–	110 (4.33)	230 (9.06)	360 (14.17)
Weight kg (lbs)	0.75 (1.7)	0.8 (1.8)	1.8 (4.0)	3.0 (6.6)	3.9 (8.6)
Max. wire size – Main terminals	10 mm ² (AWG6)				
Tightening torque – Main terminals	1.5 ... 1.8 N·m (13 ... 16 lbf·in)				
Max. wire size – Thermal switch terminals	4 mm ² (AWG12)				
Tightening torque – Thermal switch terminals	0.6 ... 0.8 N·m (5.3 ... 7.1 lbf·in)				

■ Resistor connectors on inverter modules

R+ and R- terminals	<p><u>Frame R1i</u> U2, V2, W2: 0.25...4 mm², 0.5 ... 0.6 N·m (4.4 ...5.3 lbf·in) Ground: 1.5 N·m (13 lbf·in)</p> <p><u>Frame R2i</u> U2, V2, W2: 0.5 ... 6 mm², 1.2 ... 1.5 N·m (10.6 ... 13.3 lbf·in) Ground: 1.5 N·m (13 lbf·in)</p> <p><u>Frames R3i and R4i</u> U2, V2, W2: 6...70 mm². Allen screw torque 15 N·m (11 lbf·ft), connection post torque 4 N·m (30 lbf·in). Other conductor sizes can be used by replacing the original lug with a suitable crimp ring terminal. Ground: Screw size M5, torque 3 N·m (25 lbf·in) Connector cover screws: Torque 3 N·m (25 lbf·in)</p>
---------------------	--

15

Dimension drawings

Contents of this chapter

This chapter contains dimension drawings of the ACS880-104 inverter modules as well as auxiliary components. Dimensional drawings of most installation accessories are available from ABB on request.

Frame R1i

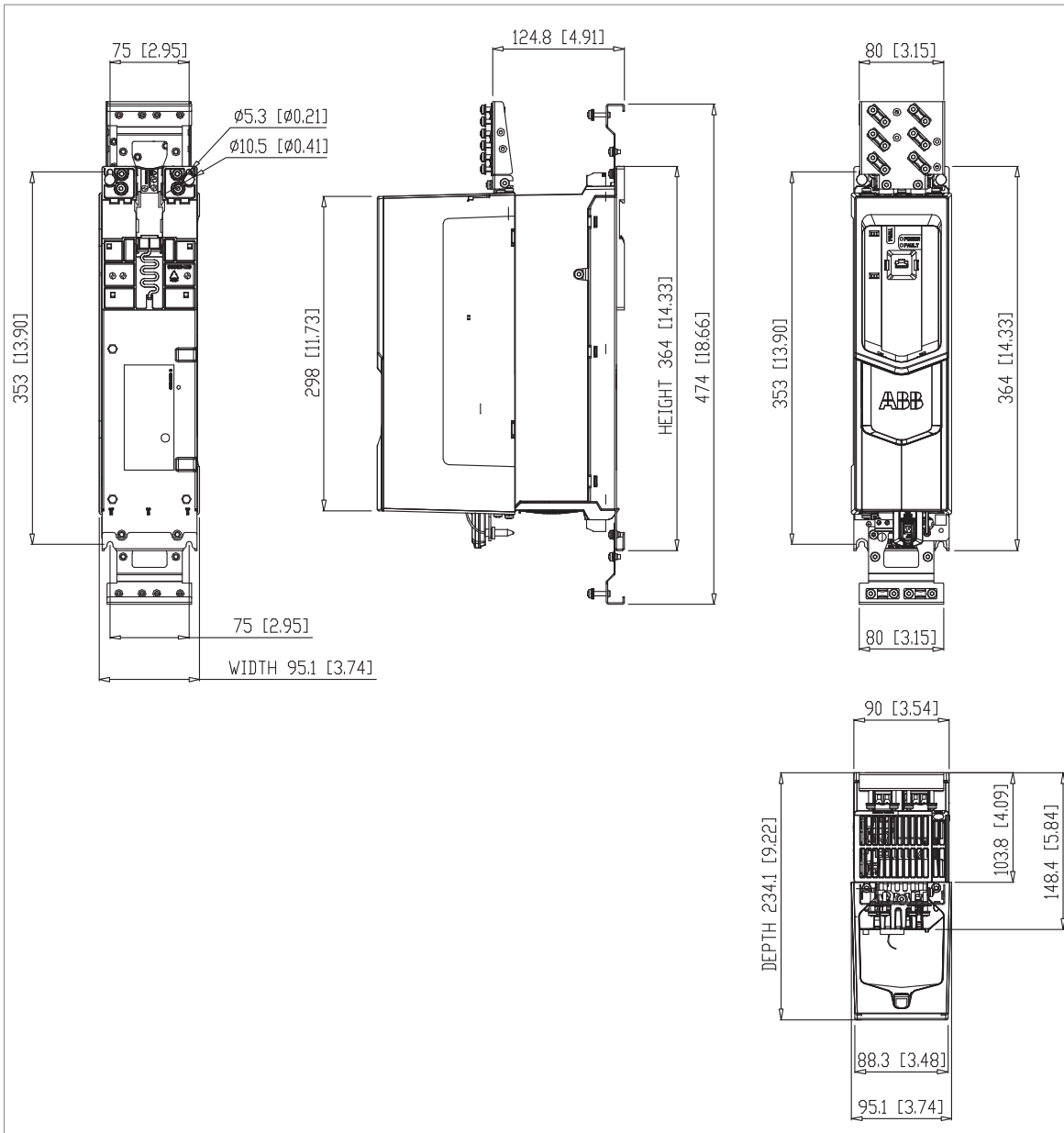

Frame R2i

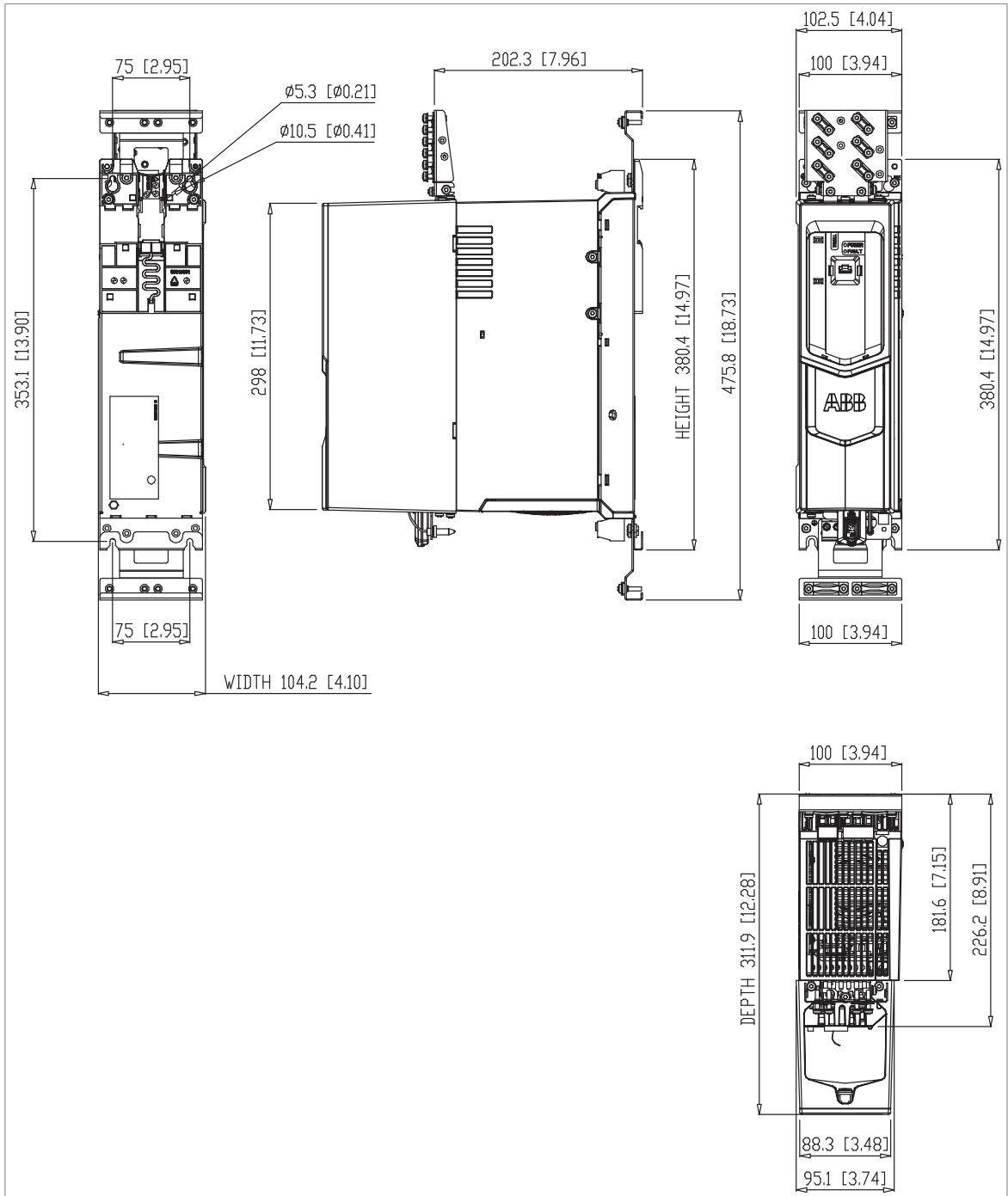

Frame R3i

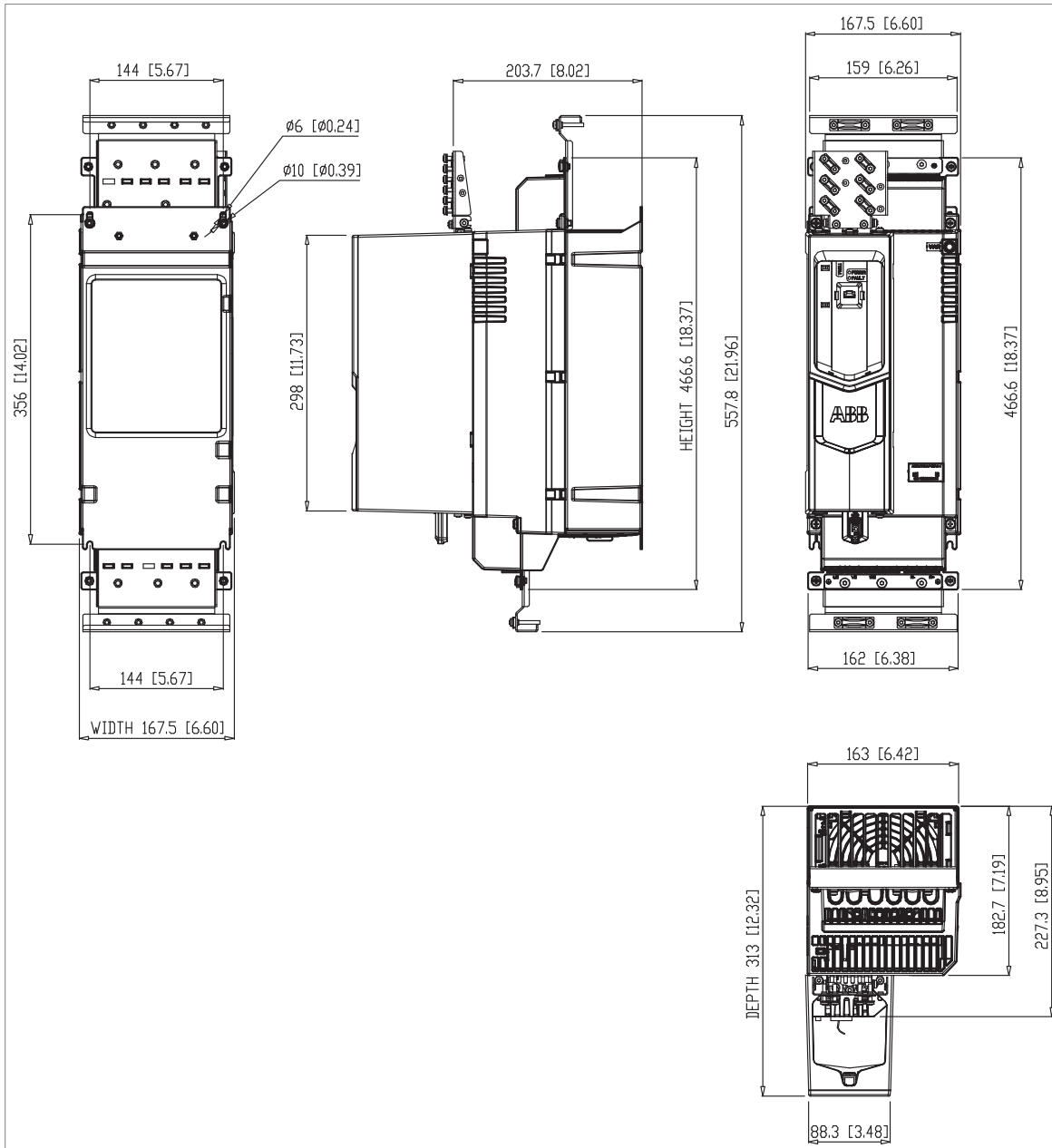

Frame R4i

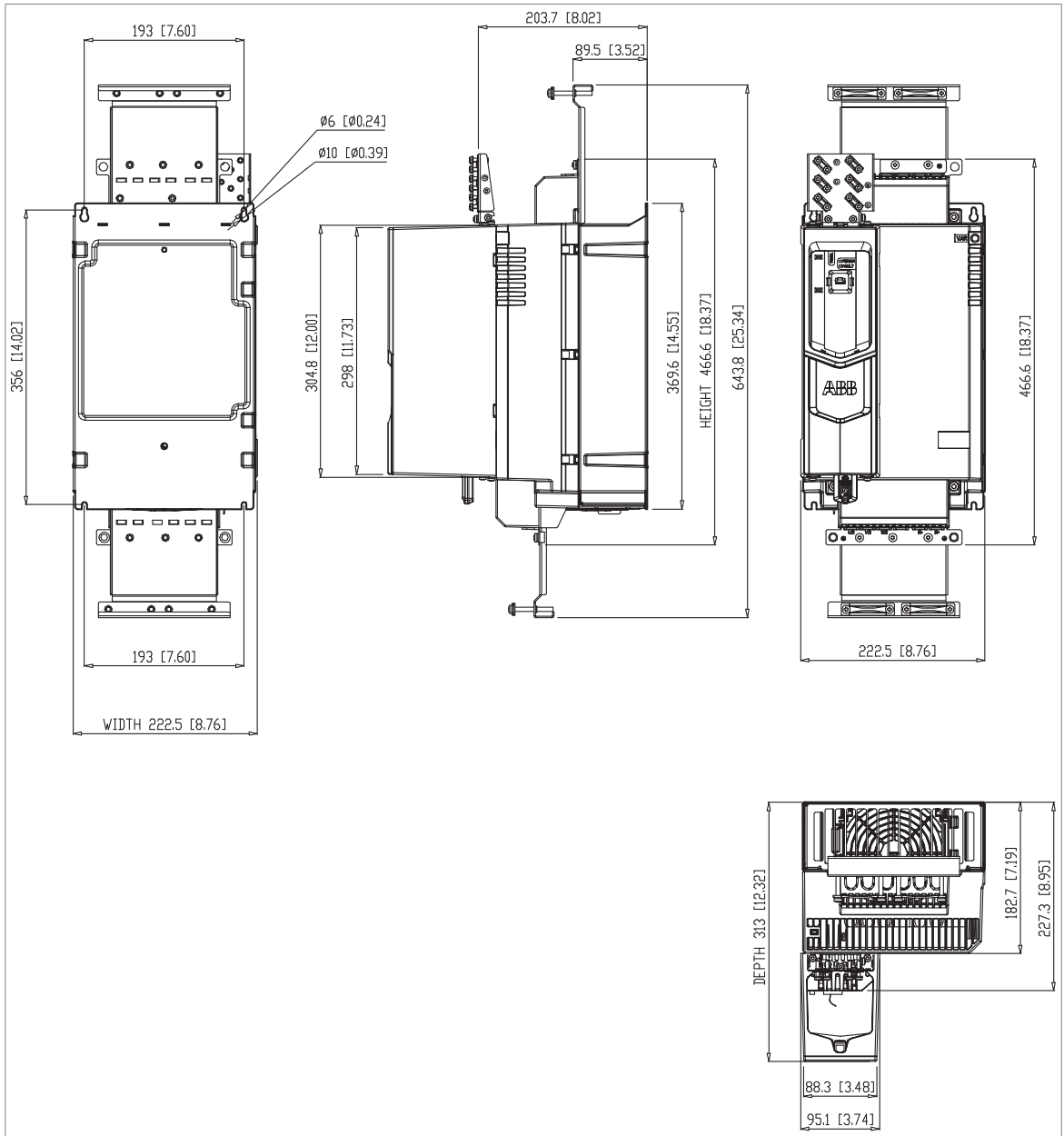

Frame R5i

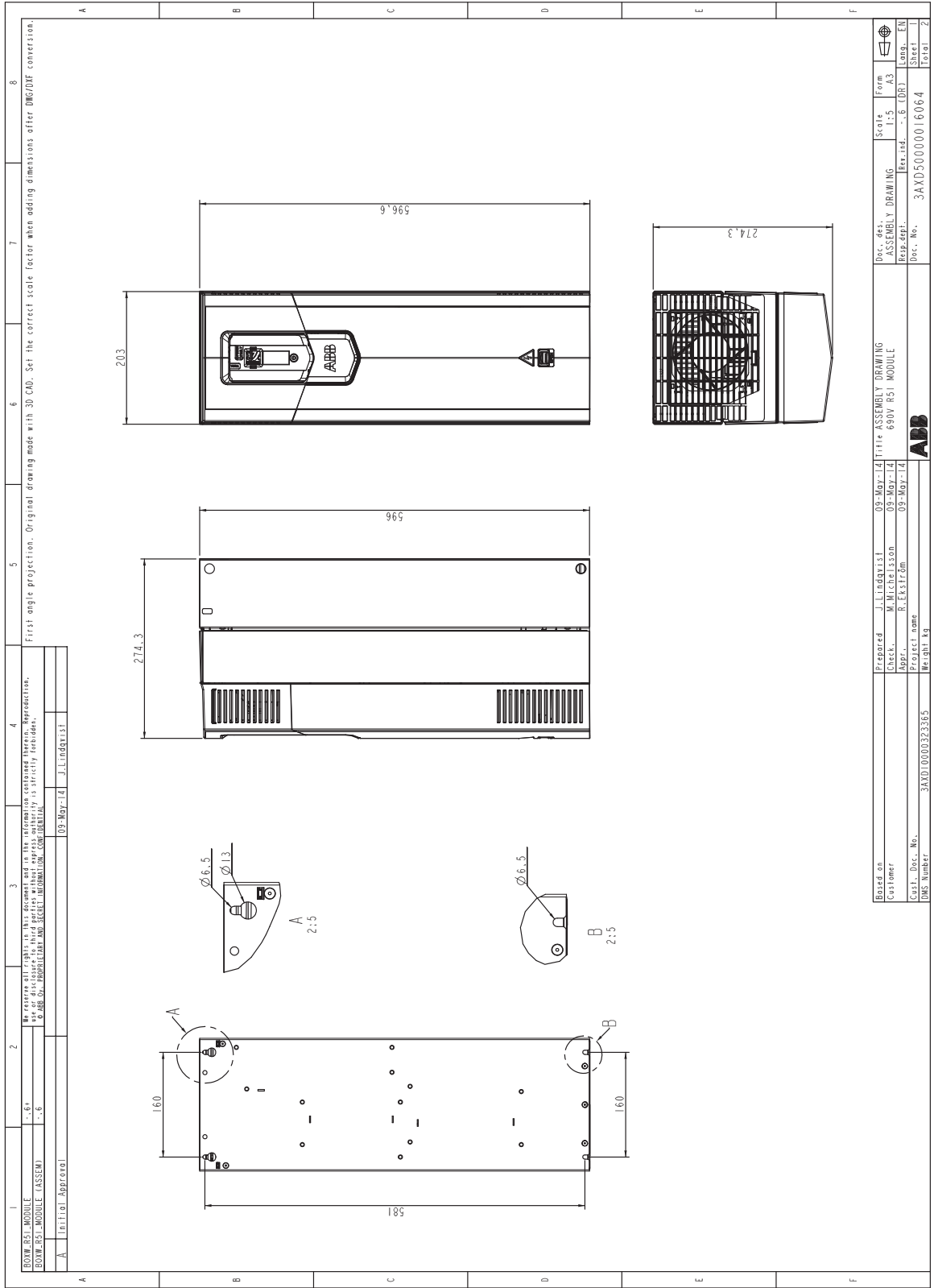

Doc. no.:	ASSEMBLY DRAWING	Scale:	1:5	Form:	AS
Rev. no.:	1	Rev. no.:	1	Rev. no.:	1
Doc. no.:	3AXD5000016064	Doc. no.:	3AXD5000016064	Doc. no.:	3AXD5000016064
Weight:	kg	Weight:	kg	Weight:	kg

Frame R6i

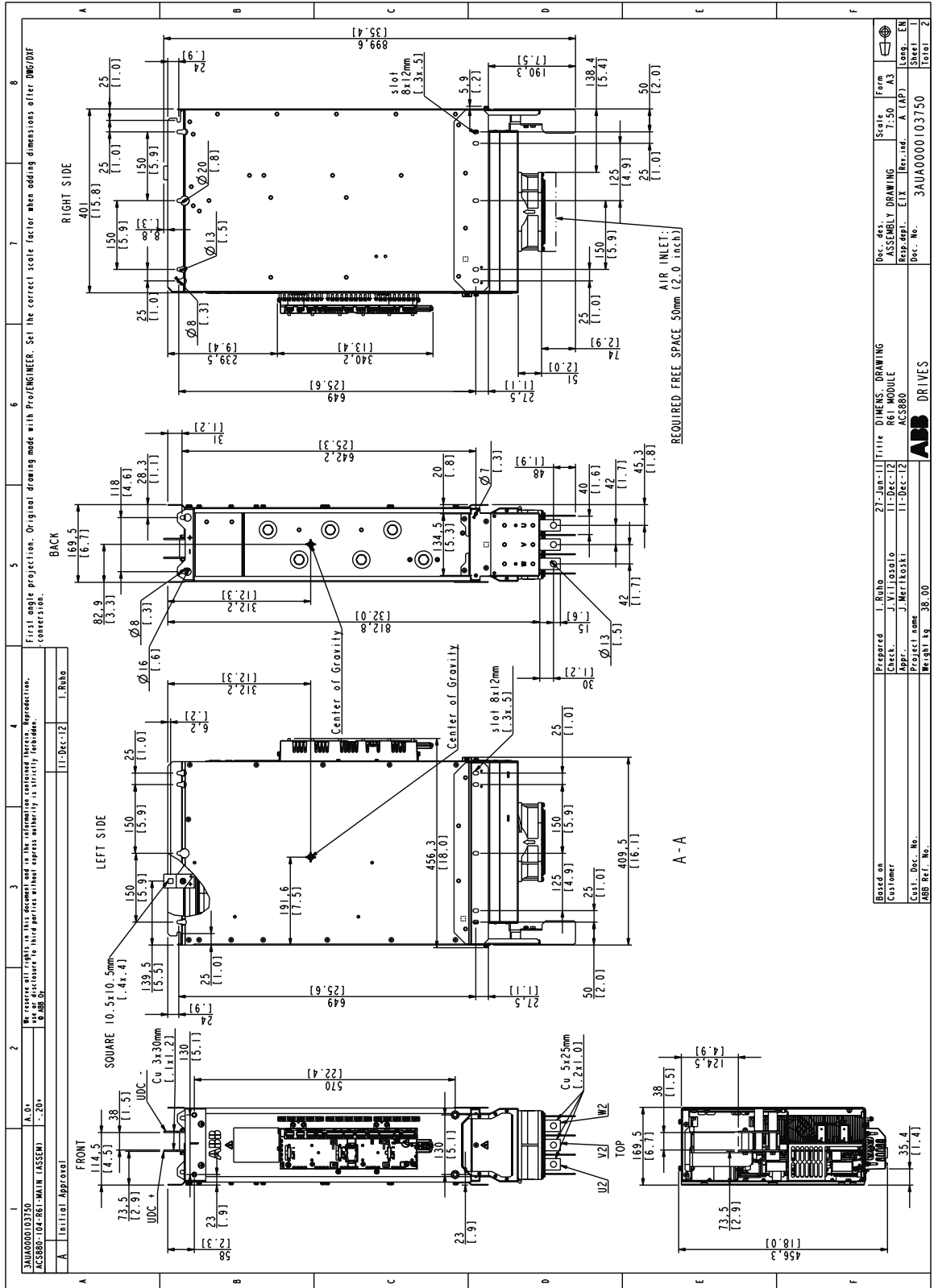

3AU0000103750	A. D.	11-Dec-12	I. Raho
ACS880-04-R6-MAN (ASSEMB)	7-20		
Initial Approval			

First angle projection. Original drawing made with Pro/ENGINEER. Set the correct scale factor when adding dimensions after DIM/DF conversion.

Based on: I. Raho 27-Jun-11 Title: DIMENS. DRAWING

Customer: J. V. Ilosalo 11-Dec-12 R6 MODULE

Appr.: J. Merikoski 11-Dec-12 ACS880

Project name: Project name

Weight kg: 38.00

Dec. des.: ASSEMBLY DRAWING

Scale: 7:50

Form: A3

Responsible: E.T.K. Rev. no.: A (AP)

Lang.: EN

Dec. No.: 3AU0000103750

Sheet: 2

Total: 2

3AU0000103750	A. D.	11-Dec-12	I. Raho
ACS880-04-R6-MAN (ASSEMB)	7-20		
Initial Approval			

Frame R8i

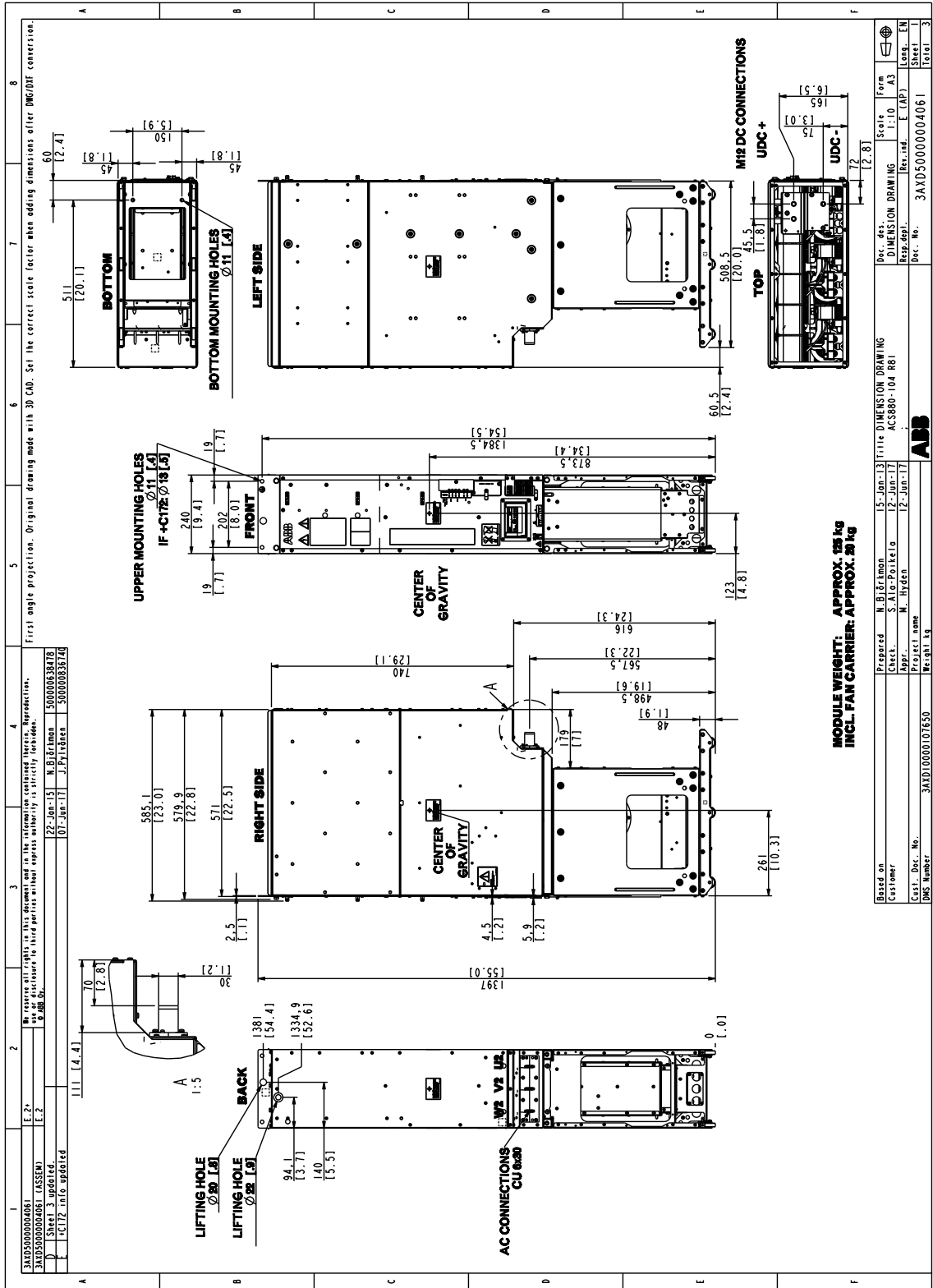

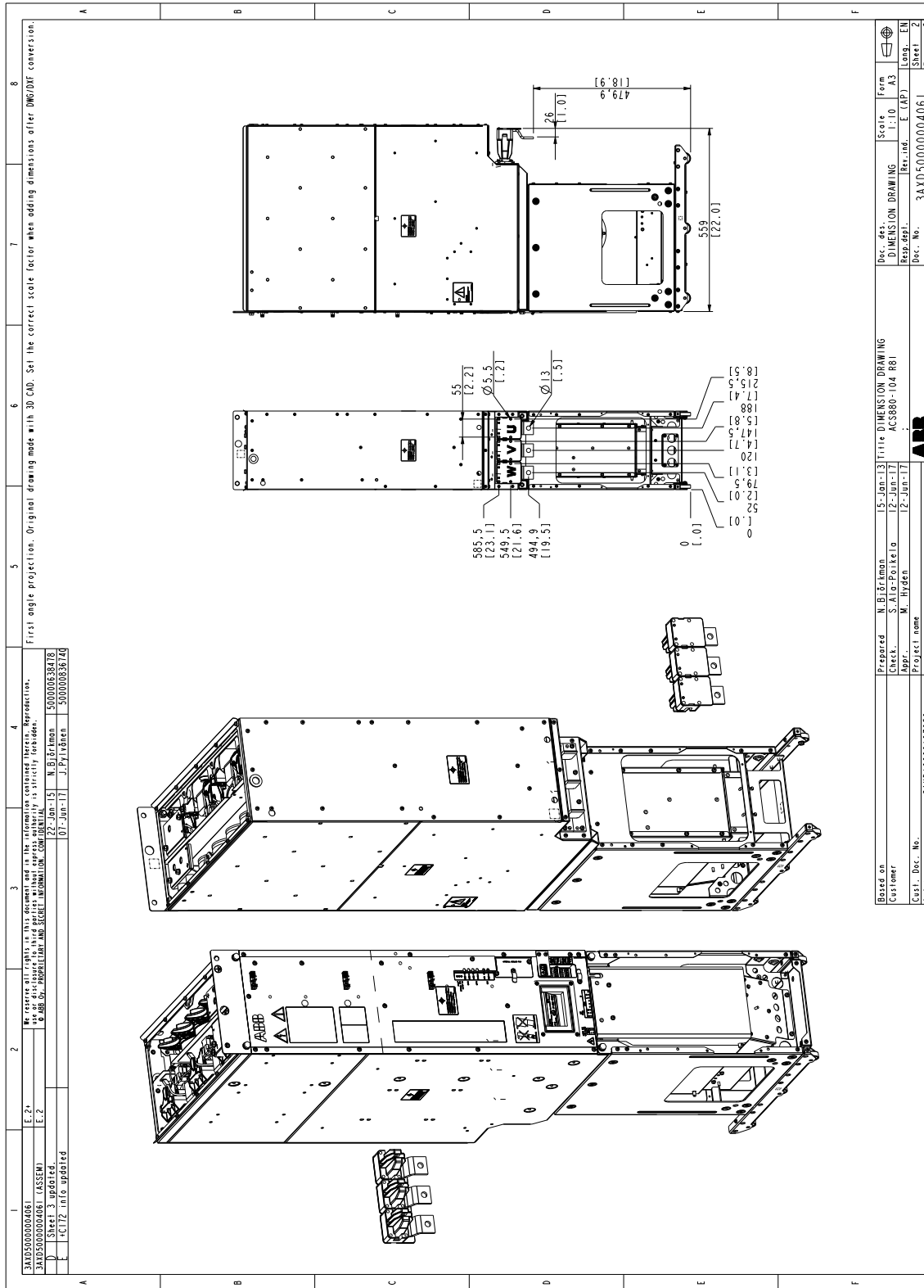

1 3AXD5000004061
 2 Sheet 3, updated
 3 436112 info updated
 4 We reserve all rights in this document and in the information contained therein. Reproduction, use or disclosure to third parties without express authority is strictly forbidden.
 5 07-Jun-17 J.P. Viikari 500000036740
 6
 7
 8

First angle projection. Original drawing made with 3D CAD. Set the correct scale factor when adding dimensions after DWG/DXF conversion.

Frame R8i with option +P942

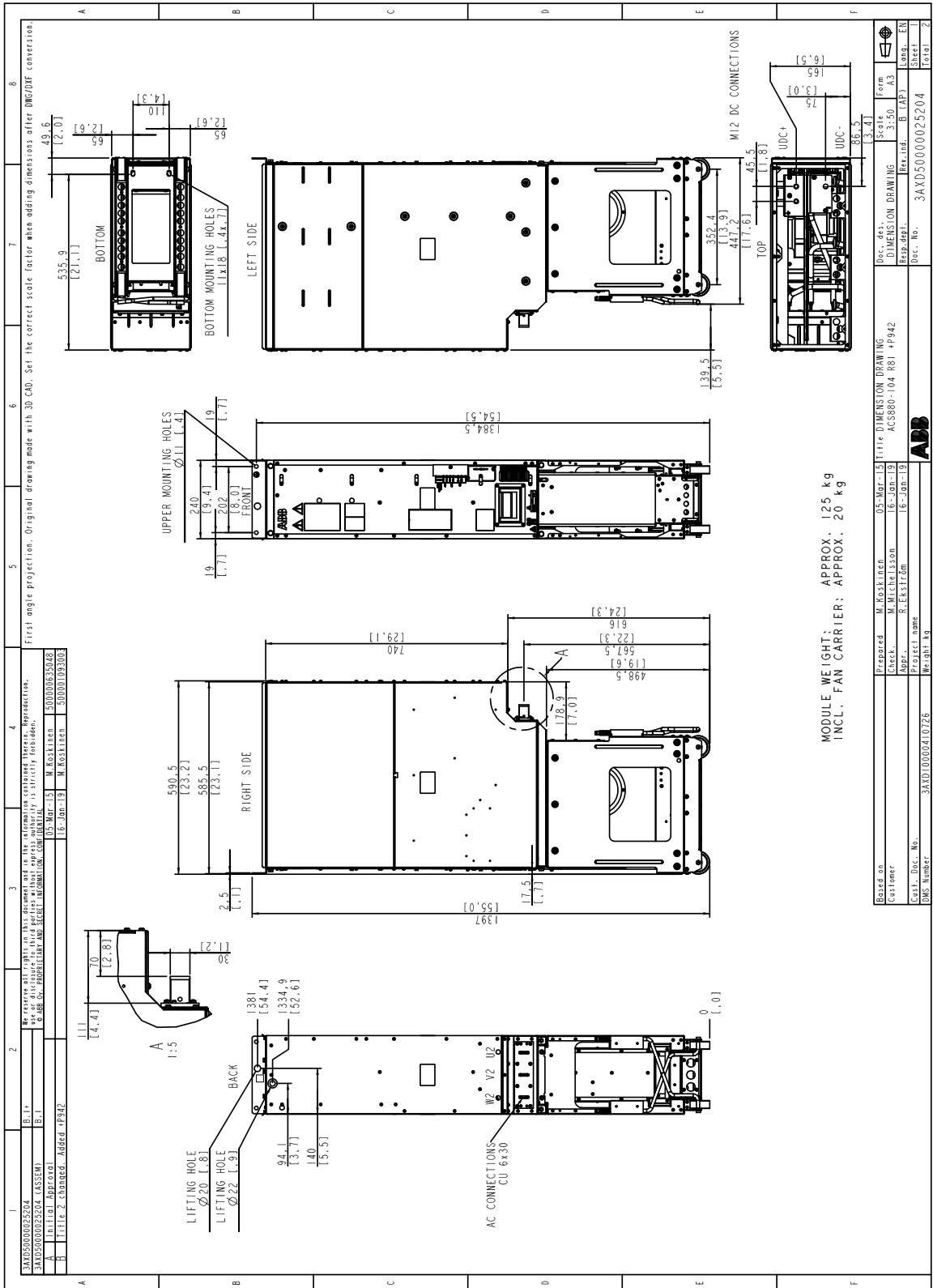

MODULE WEIGHT: APPROX. 125 kg
INCL. FAN CARRIER: APPROX. 20 kg

Doc. No.	3AXD50000025204	Doc. No.	3AXD50000025204
Doc. Name	3AXD10000410726	Doc. Name	3AXD50000025204
Doc. Title	3AXD10000410726	Doc. Title	3AXD50000025204
Doc. Author	M. Koskinen	Doc. Author	M. Koskinen
Doc. Check	M. Koskinen	Doc. Check	M. Koskinen
Doc. Date	18-Jan-19	Doc. Date	18-Jan-19
Doc. Rev.	18-Jan-19	Doc. Rev.	18-Jan-19
Doc. Scale	3:50	Doc. Scale	3:50
Doc. Form	A3	Doc. Form	A3
Doc. Title	3AXD10000410726	Doc. Title	3AXD50000025204
Doc. Title	3AXD10000410726	Doc. Title	3AXD50000025204



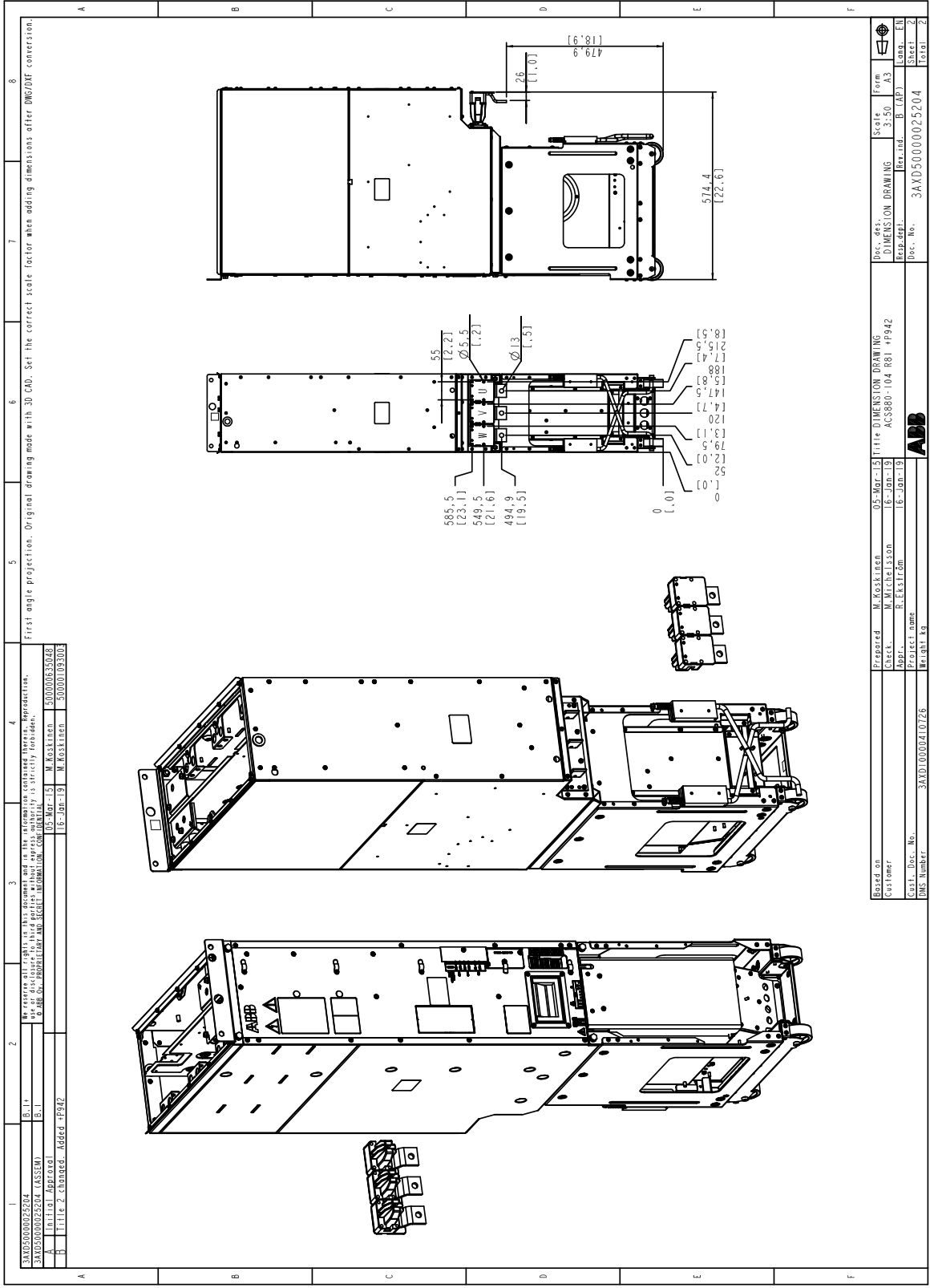

First angle projection. Original drawing made with 3D CAD. Set the correct scale factor when adding dimensions after DWG/DAF conversion.

1	3AXD5000025204	B.1*	15-Jan-19	M. Koskinen	500000635048
2	ABB Switchgear Assembly	B.1	15-Jan-19	M. Koskinen	500000635048
3	ABB Switchgear Assembly	B.1	15-Jan-19	M. Koskinen	500000635048
4	ABB Switchgear Assembly	B.1	15-Jan-19	M. Koskinen	500000635048
5	ABB Switchgear Assembly	B.1	15-Jan-19	M. Koskinen	500000635048
6	ABB Switchgear Assembly	B.1	15-Jan-19	M. Koskinen	500000635048
7	ABB Switchgear Assembly	B.1	15-Jan-19	M. Koskinen	500000635048
8	ABB Switchgear Assembly	B.1	15-Jan-19	M. Koskinen	500000635048

Doc. des.:	DIMENSION DRAWING	Scale:	3:50	Form:	A3
Doc. No.:	3AXD5000025204	Rev. No.:	B (VAP)	Conv.:	EU
Prepared:	M. Koskinen	05-Mar-15	Title:	DIMENSION DRAWING	
Checked:	M. Mitchellsson	15-Jan-19	Customer:	ACS880-104 R81 #P942	
Approved:	R. Ekström	15-Jan-19	Project name:	ABB	
Drawn:	M. Koskinen	15-Jan-19	Drawn by:	ABB	
Checked:	M. Mitchellsson	15-Jan-19	Checked by:	ABB	
Approved:	R. Ekström	15-Jan-19	Approved by:	ABB	
Doc. No.:	3AXD5000025204	Rev. No.:	B (VAP)	Conv.:	EU
Form:	A3	Scale:	3:50	Doc. des.:	DIMENSION DRAWING

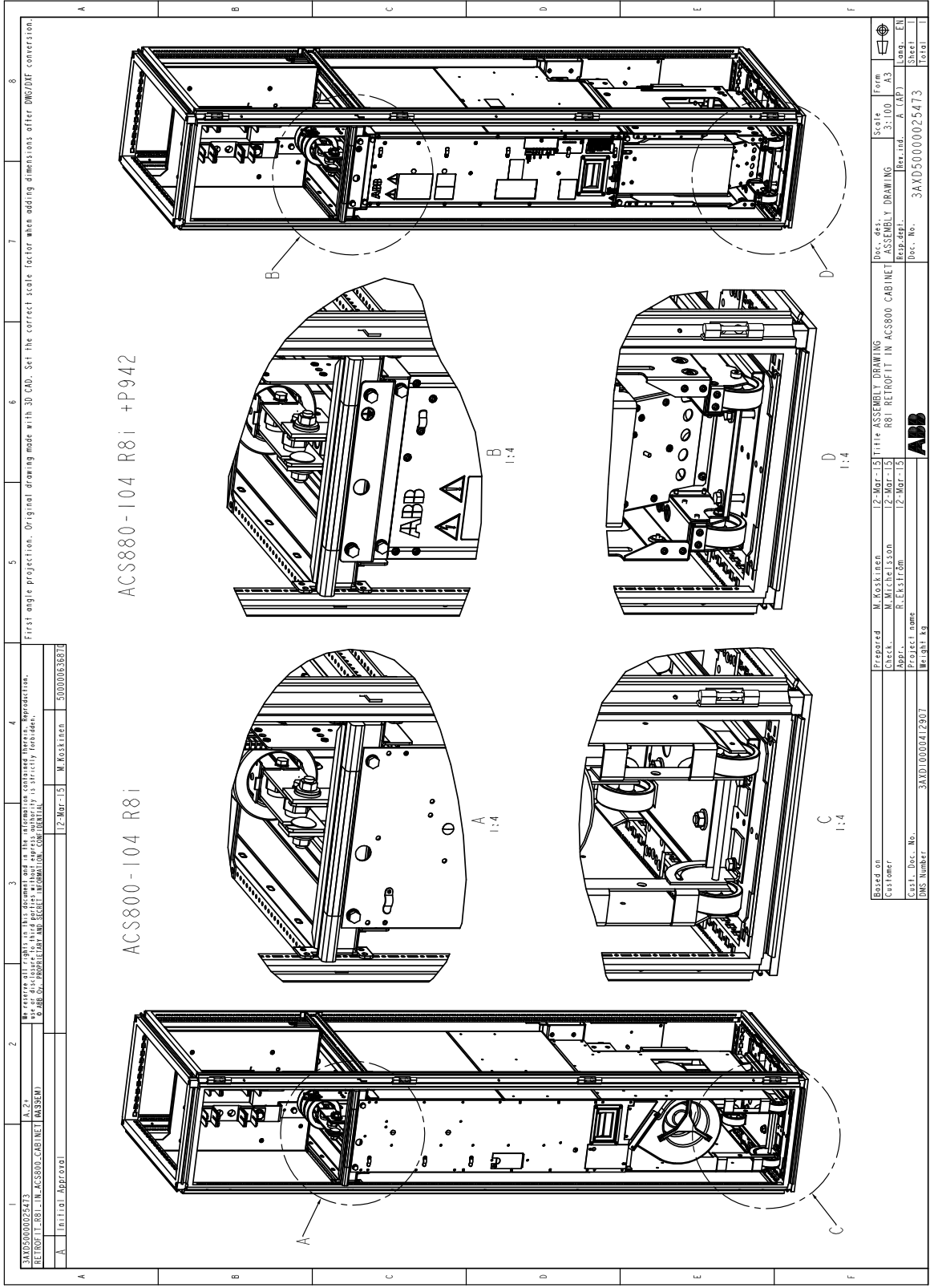

1
2
3
4
5
6
7
8

First angle projection. Original drawing made with 3D CAD. Set the correct scale factor when adding dimensions after DWG/DXF conversion.

3AXD5000025473	A.21	12-Mar-15	M. Koskinen	5000003687
RETROFIT R8i IN ACS800 CABINET ASSEMBLY				
Initial Approval				

ACS800-104 R8i

ACS880-104 R8i + P942

A 1:4

B 1:4

C 1:4

D 1:4

Based on	M. Koskinen	12-Mar-15	Filter ASSEMBLY DRAWING	Dec. dets.	ASSEMBLY DRAWING	Scale	3:100	Form	A3
Customer	M. Michelsson	12-Mar-15	R8i RETROFIT IN ACS800 CABINET	Prep.dets.					
Proj. name	R. Ekström	12-Mar-15		Bar.ind.	A. APJ				
Proj. No.	3AXD10000472907			Dec. No.	3AXD5000025473				
DWG Number				Weight	kg				
ABB									
Total									

Control electronics

■ ZCU control unit

Note: The control cable grounding plate can be attached to either top or bottom edge of the control unit.

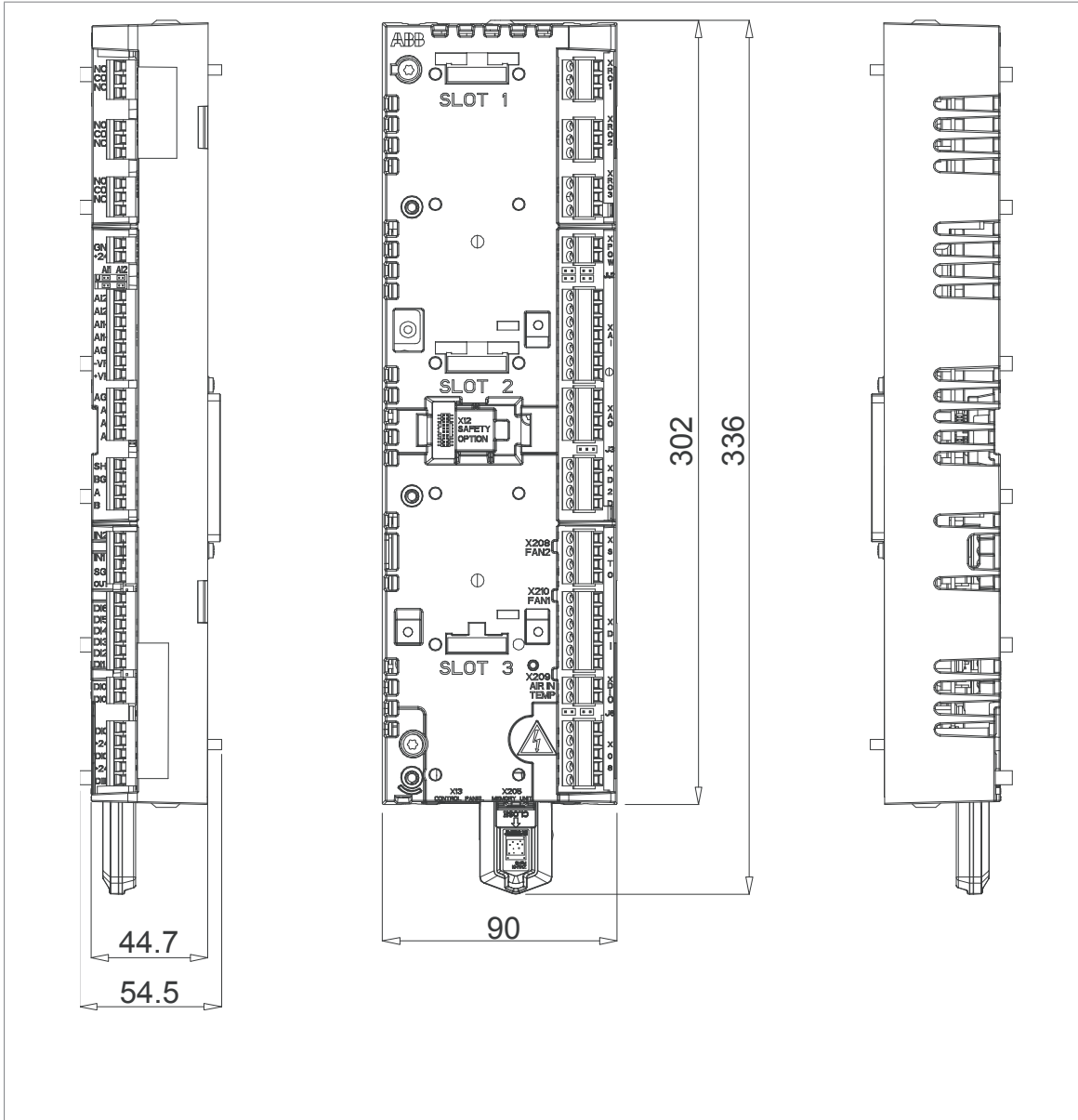

■ UCU-22 control unit

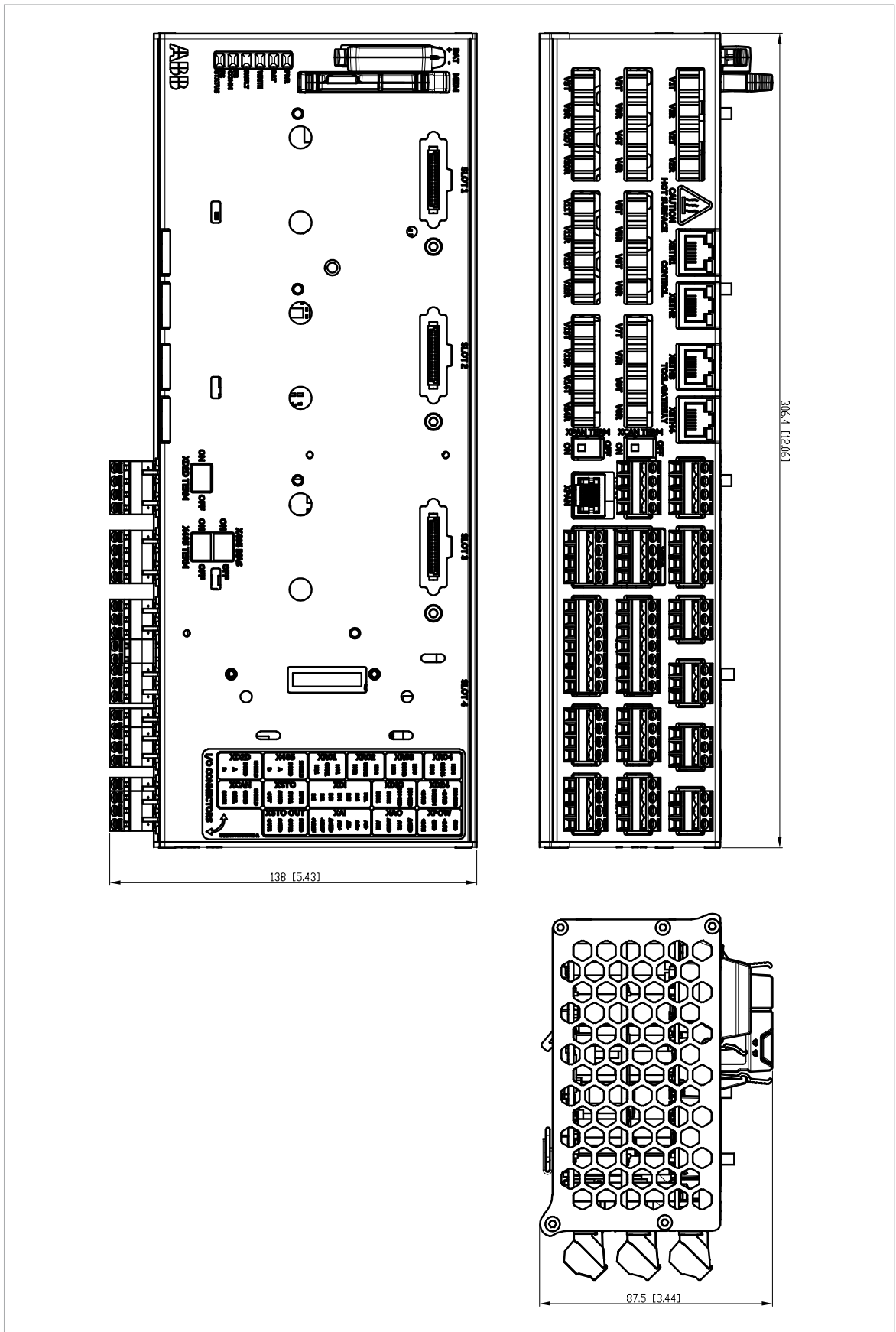

■ BCU control unit

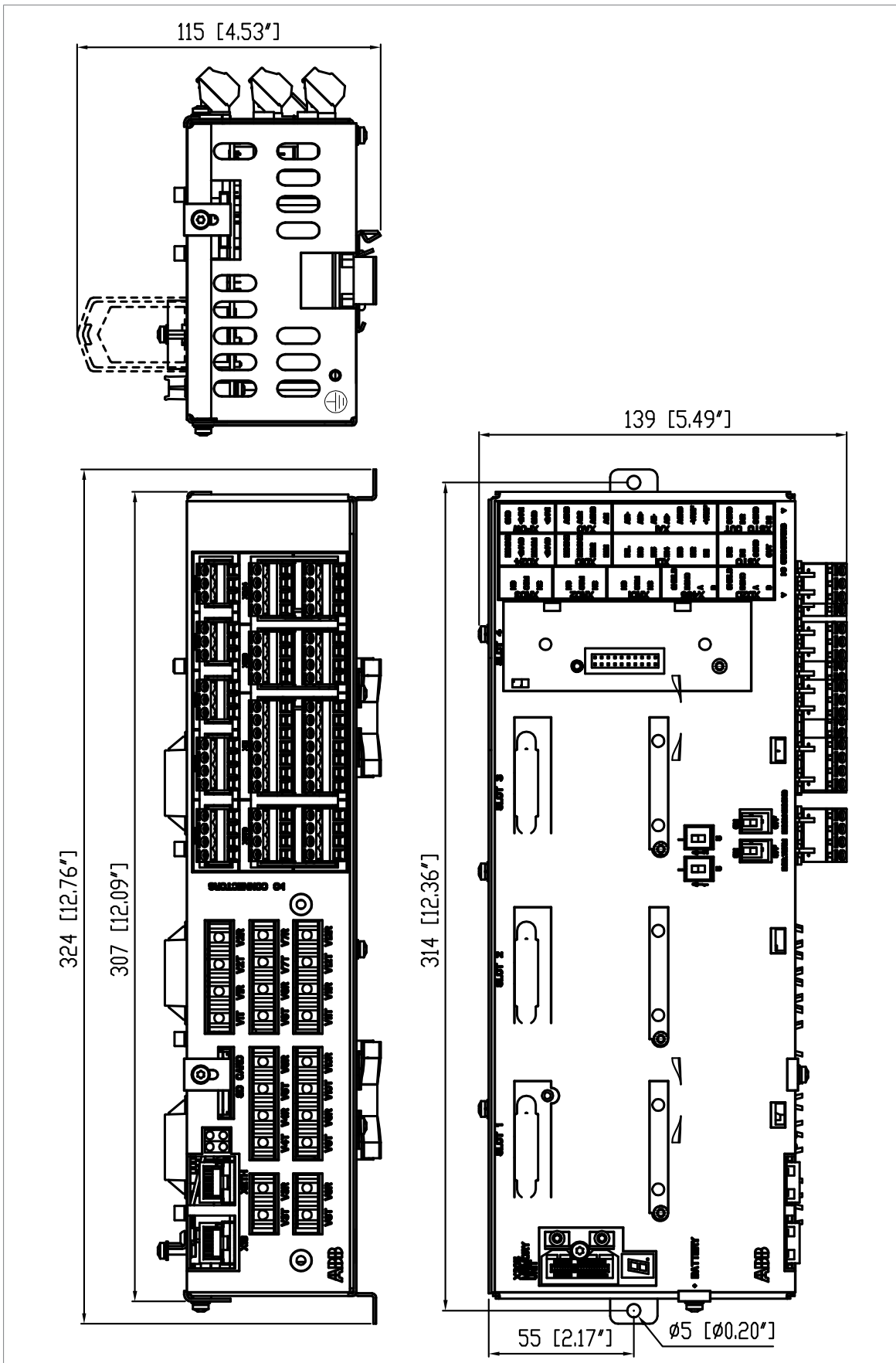

■ DPMP-01 door mounting kit

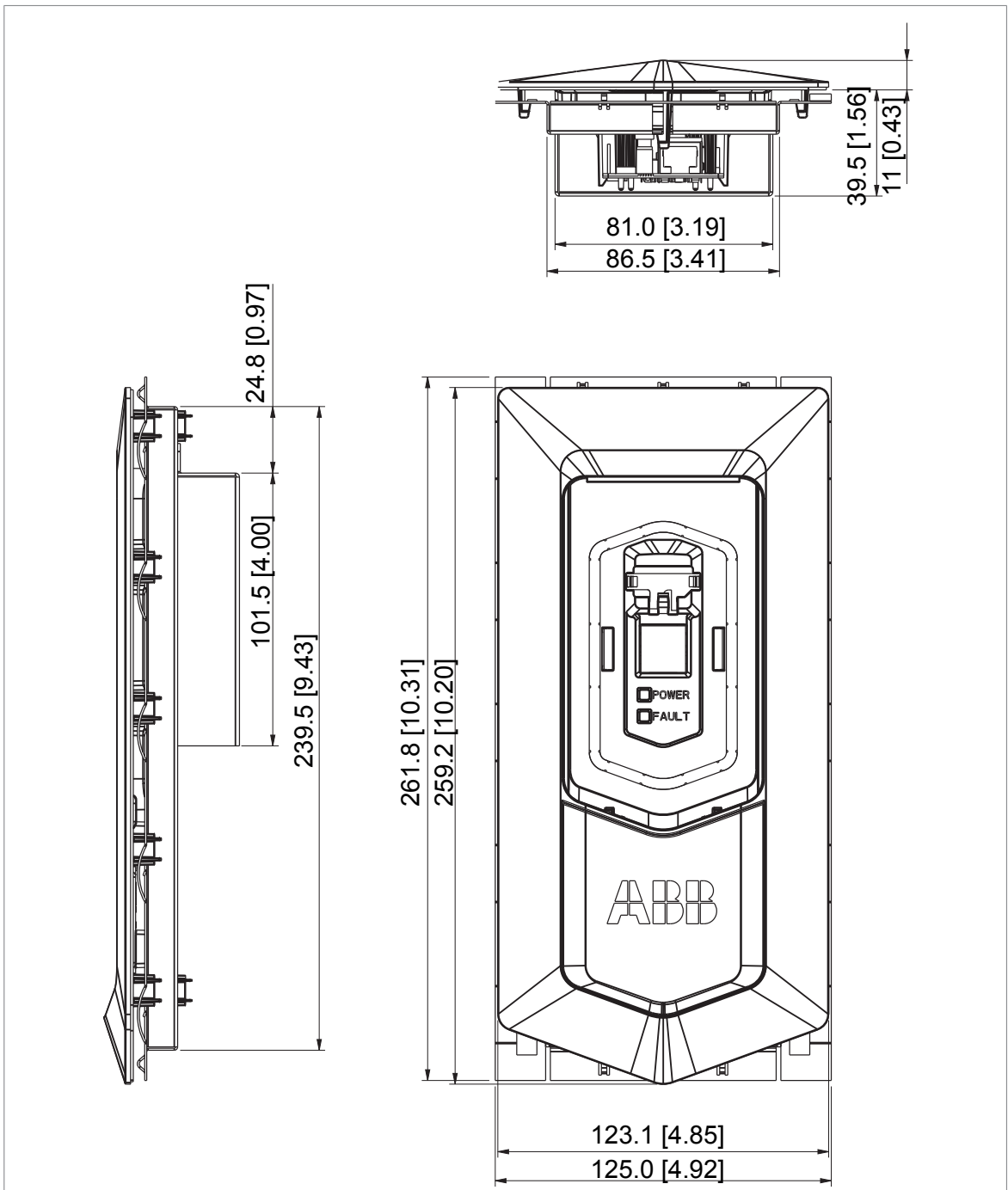

Cutting in the cabinet door: 109 mm × 223 mm (4.29 in. × 8.78 in.)

Plate thickness: 1.5 ... 2.5 mm (0.06 ... 0.10 in.)

DC fuses and fuse bases

■ Fuse, 14 × 51 mm

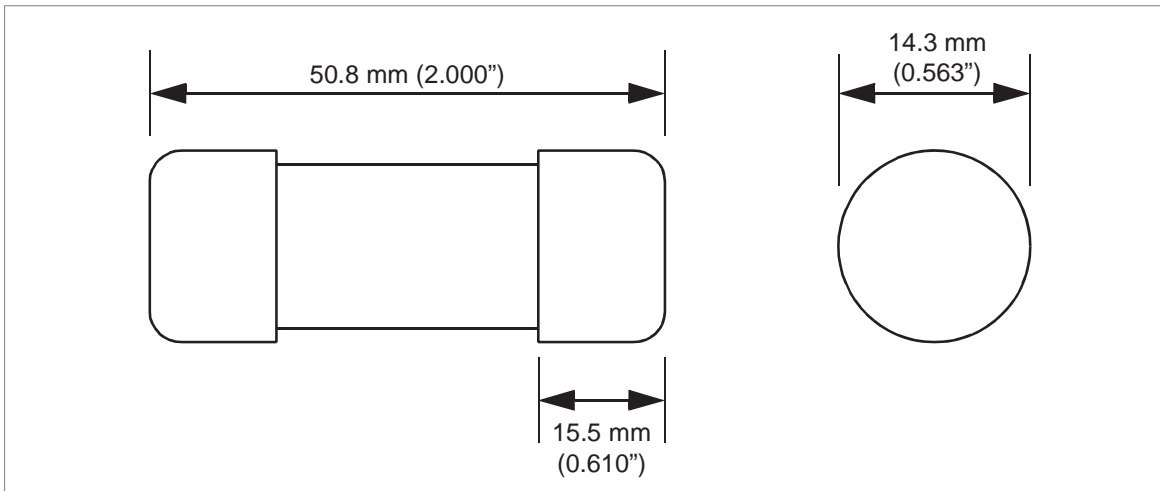

■ Mersen US141 (Z331153F) fuse disconnecter (for 14 × 51 mm fuses)

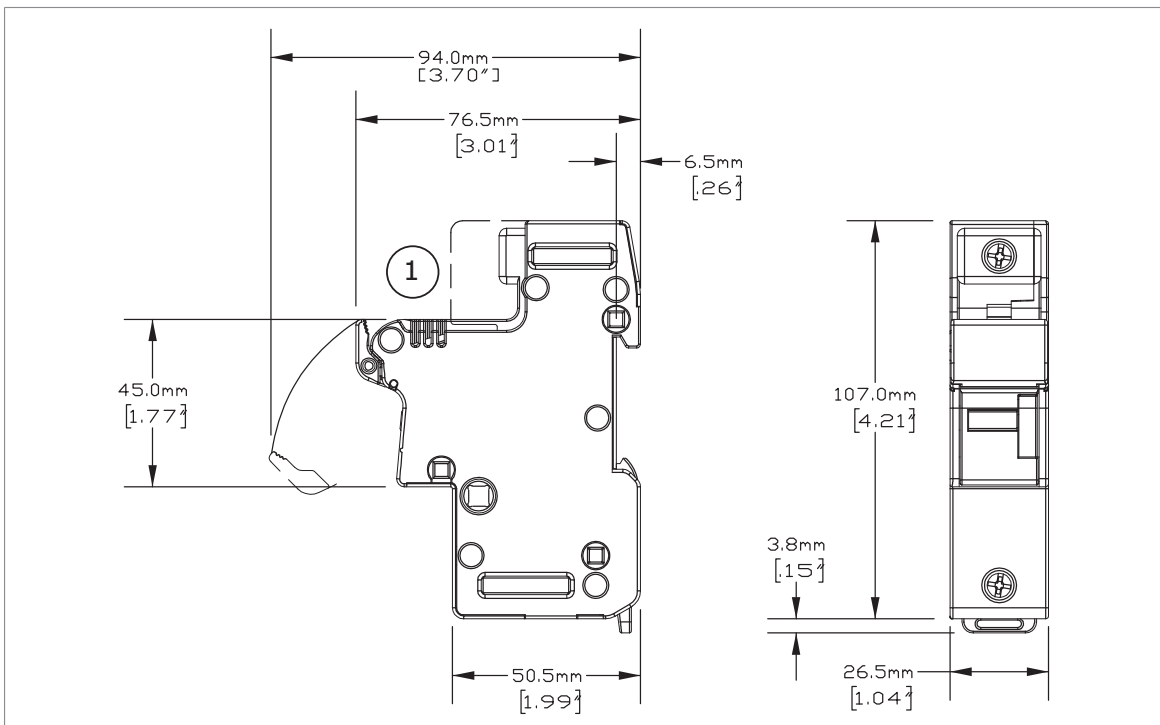

1. **Note:** On microswitch versions only

■ Fuse, 27 × 60 mm

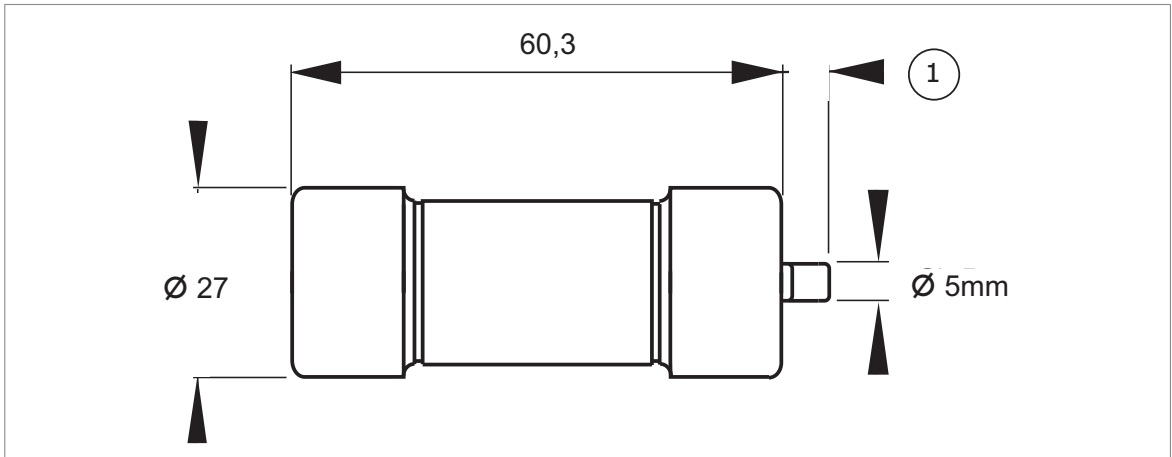

1. 7 mm indicator travel

■ Mersen US271MI (R227600C) fuse disconnecter (for 27 × 60 mm fuses)

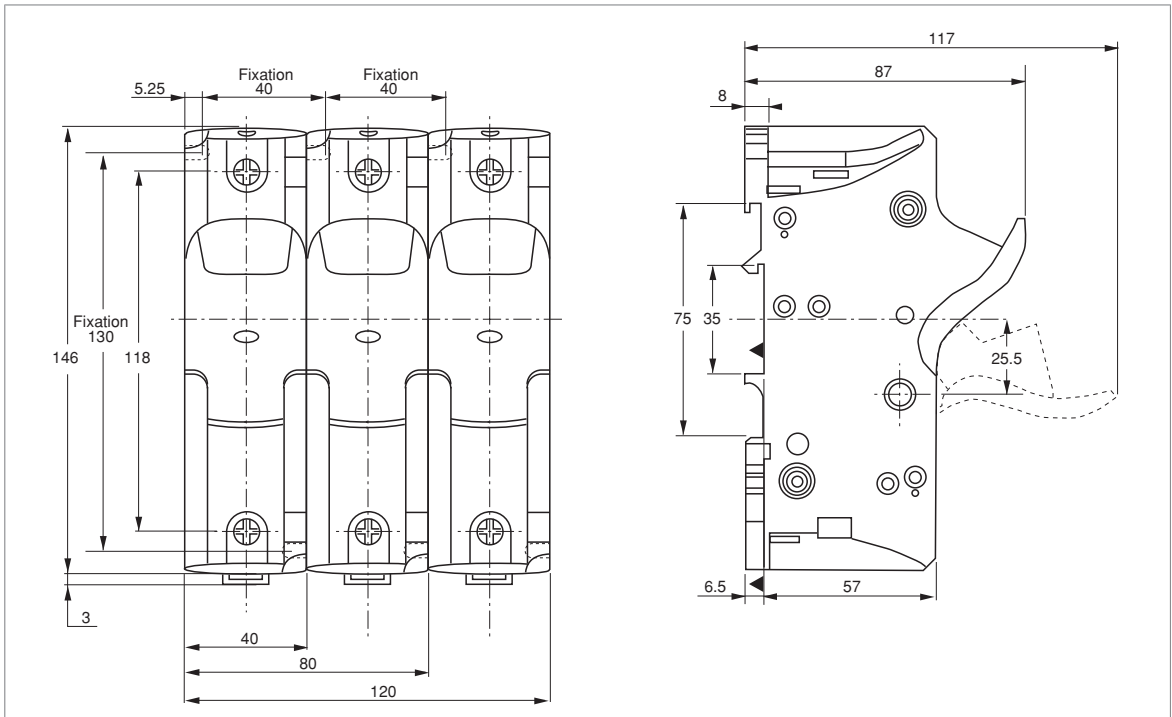

■ Mersen PS272PREMCPS (N220076) fuse disconnector (for R5i, 27 × 60 mm fuses)

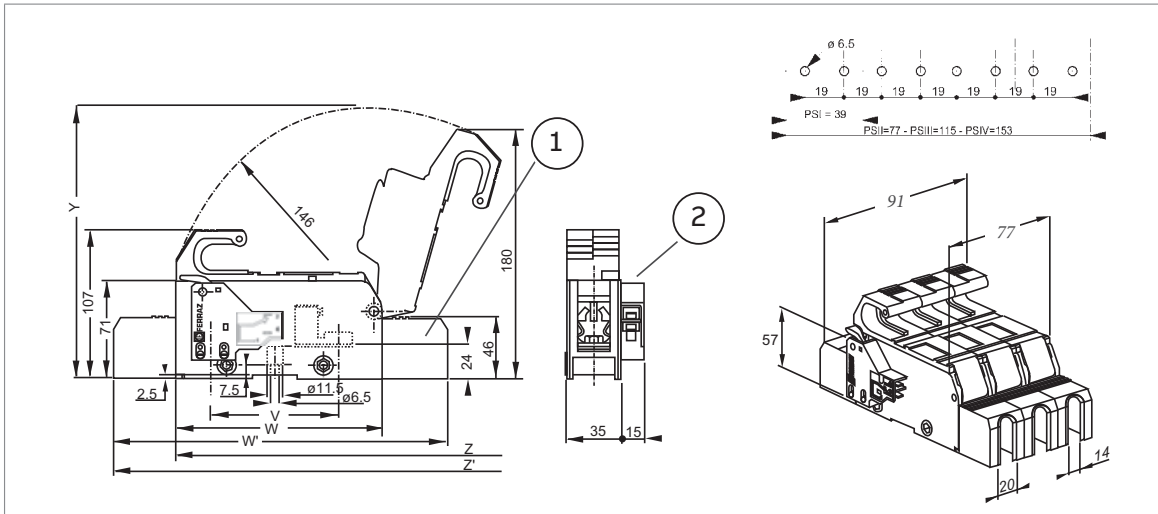

1	Twin terminal covers PS 27 Part #: A 220087 Weight: 30 g Packaging: 3 twins
2	MC PS
V	93 Connecting distance between centers
W	150 Without terminals cover length
W'	240 With terminals cover length
Y	196 Space factor with a 90° fuse carrier position
Z	284 Without terminal cover, space factor with a 180° fuse carrier position
Z'	279 With terminal cover, space factor with a 180° fuse carrier position

■ DC fuse blocks (Bussmann)

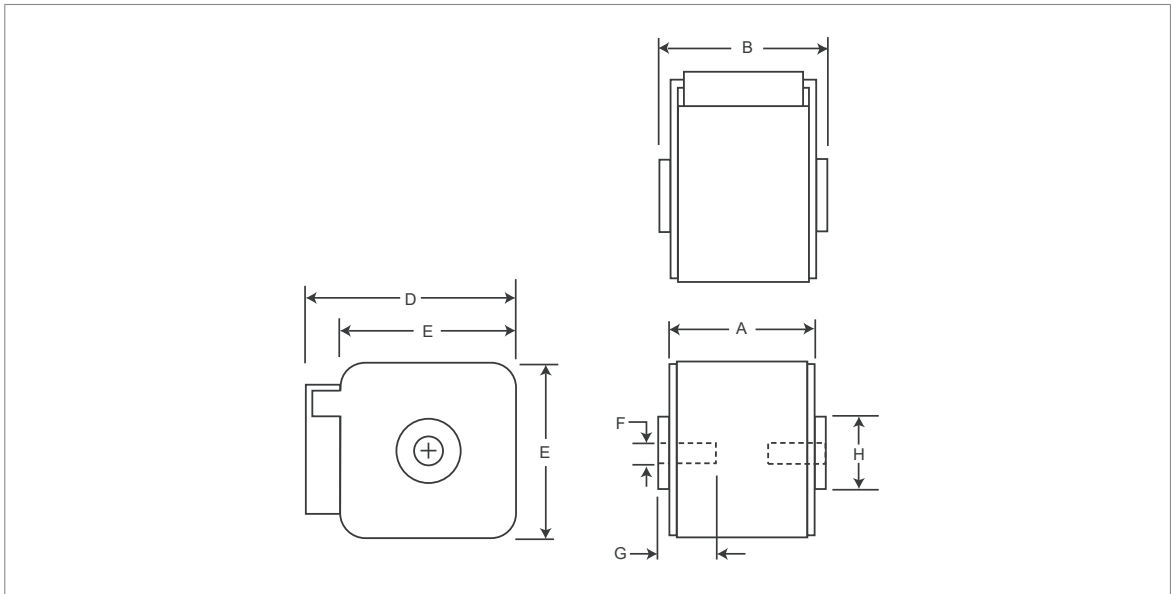

690 V fuses (as used with 400 and 500 V units)

Size	A mm (inch)	B mm (inch)	D mm (inch)	E mm (inch)	F	G mm (inch)	H mm (inch)
1	50 (1.97)	51 (2.01)	69 (2.72)	53 (2.09)	M8	8 (0.31)	20 (0.79)
3	51 (2.01)	53 (2.09)	92 (3.62)	76 (2.99)	M12	10 (0.39)	30 (1.18)
3*	51 (2.01)	65 (2.56)	92 (3.62)	76 (2.99)	M12	10 (0.39)	30 (1.18)

1000...1250 V fuses (as used with 690 V units)

Size	A mm (inch)	B mm (inch)	D mm (inch)	E mm (inch)	F	G mm (inch)	H mm (inch)
1*	74 (2.91)	75 (2.95)	59 (2.32)	45 (1.77)	M8	5 (0.20)	17 (0.67)
1	74 (2.91)	75 (2.95)	69 (2.72)	53 (2.09)	M8	8 (0.31)	20 (0.79)
3	81 (3.19)	83 (3.27)	92 (3.62)	76 (2.99)	M12	10 (0.39)	30 (1.18)

Switchgear and charging components

■ OS_switch fuses

OS100GJ04FP

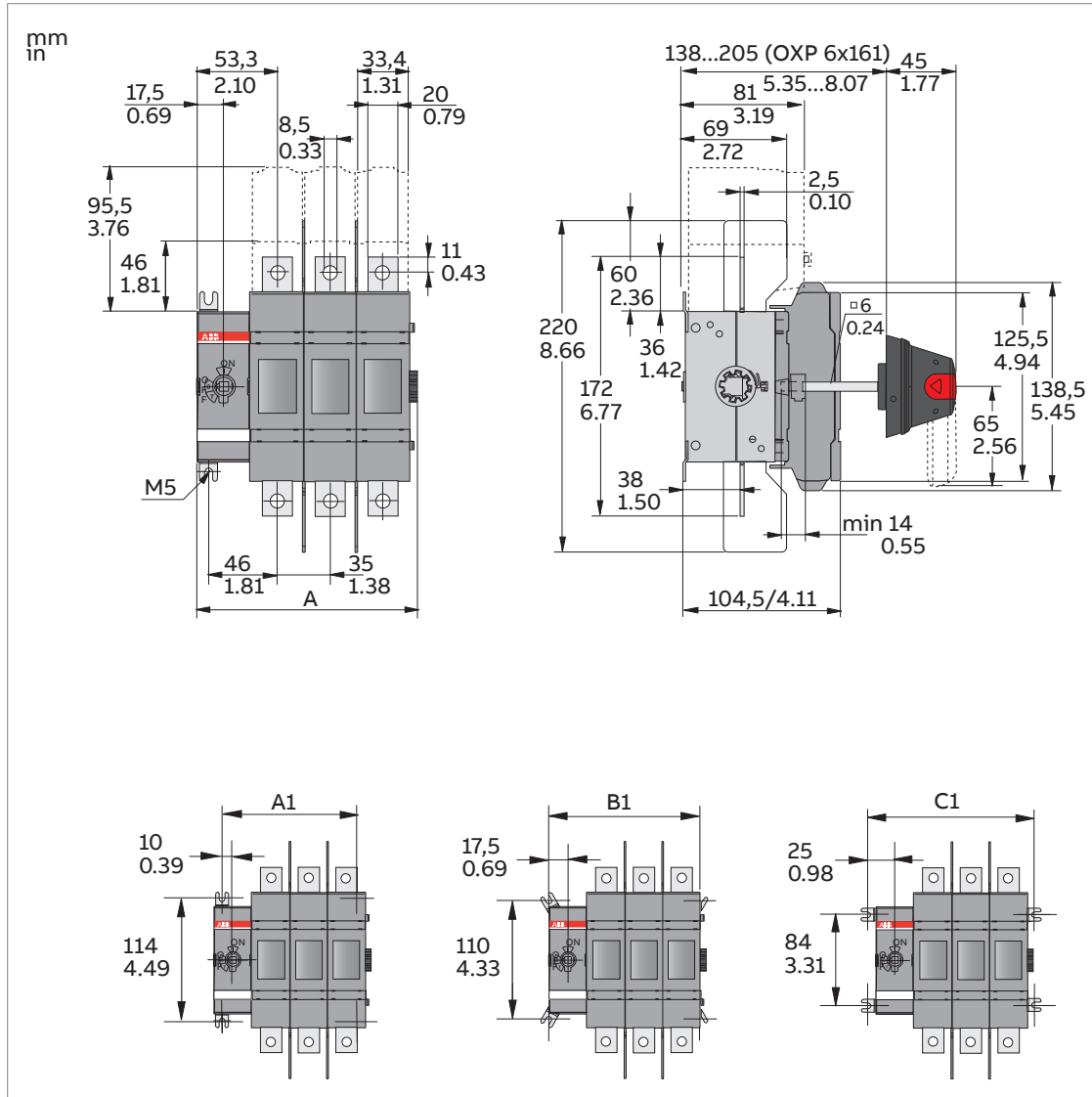

	mm (in)
A	181.5 (7.15)
A1	160 (6.30)
B1	175 (6.89)
C1	190 (7.48)

OS160GD04F

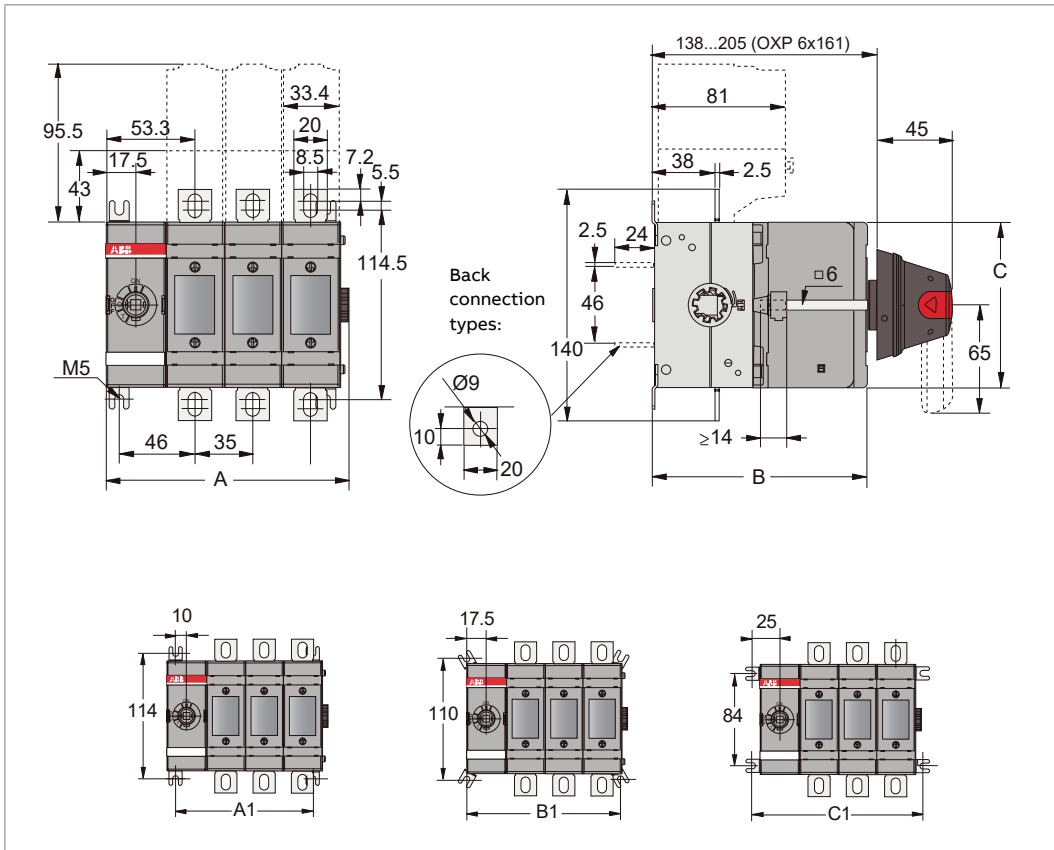

	mm (in)
A	181.5 (7.15)
B	130 (5.12)
C	100 (3.94)
A1	160 (6.30)
B1	175 (6.89)
C1	190 (7.48)

■ OT_switch/disconnectors

OT200E11

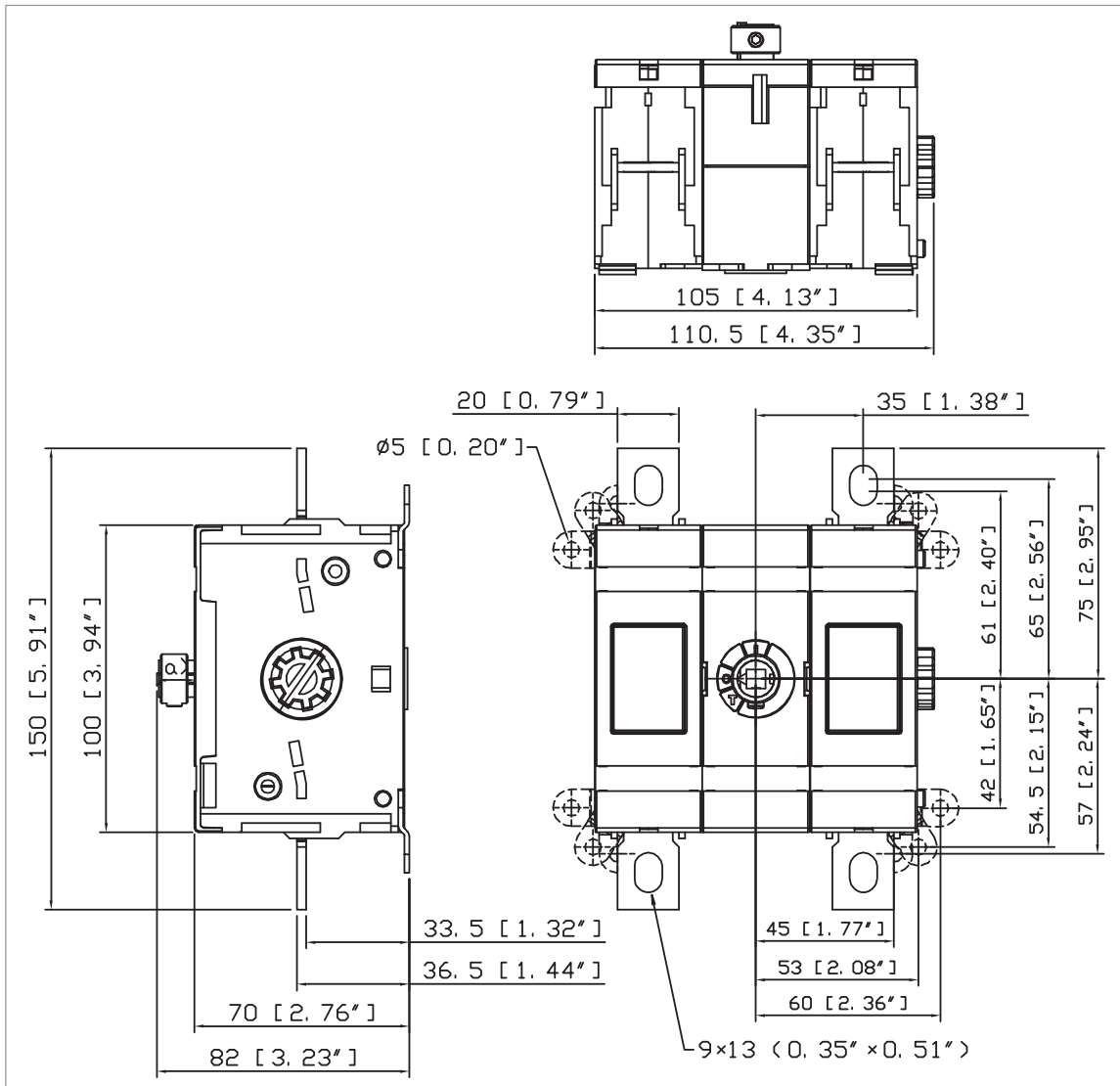

a) The shaft must extend into switch at least 14 mm (0.55").

OT200U11

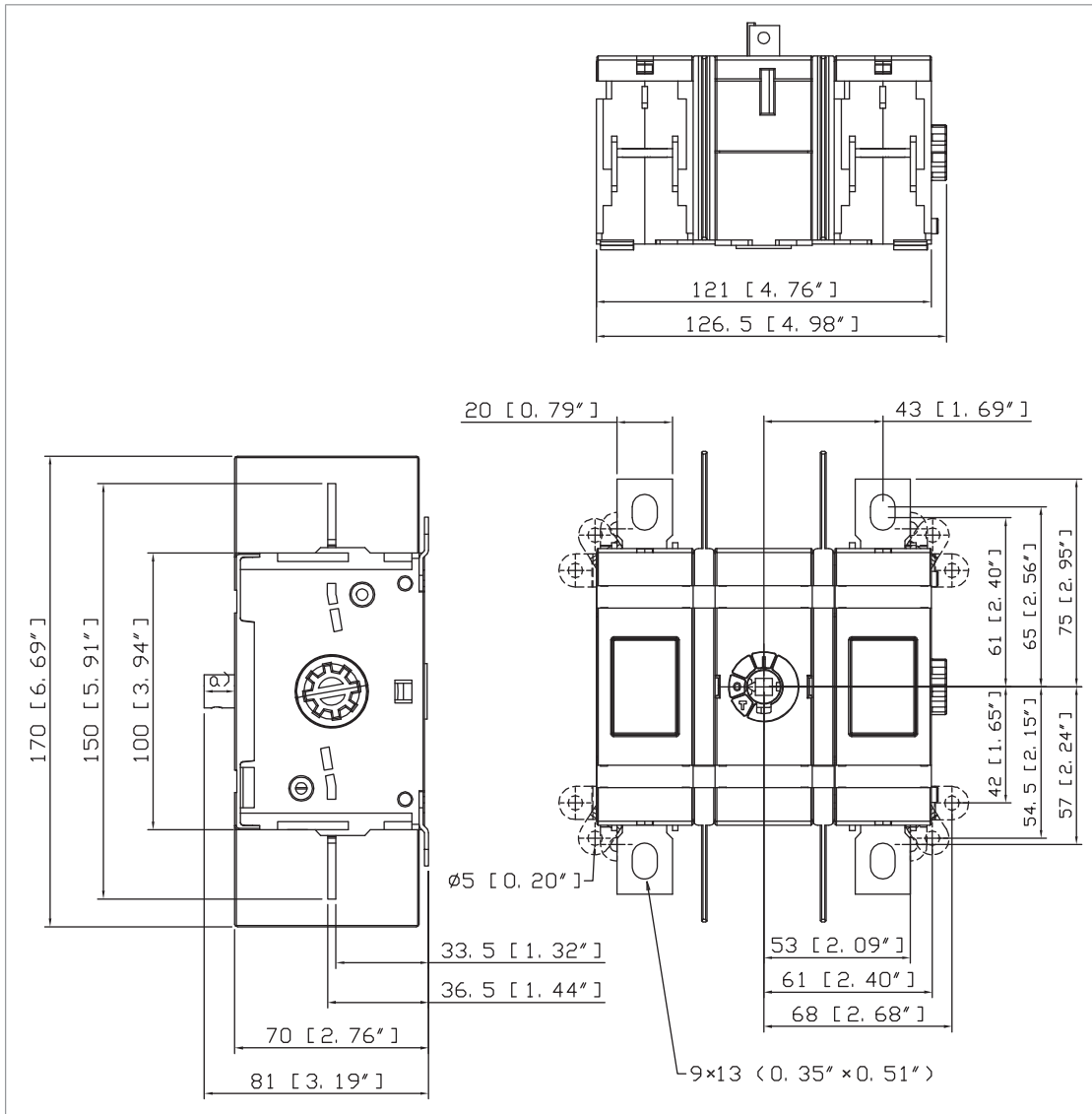

a) The shaft must extend into switch at least 14 mm (0.55").

OT400E11

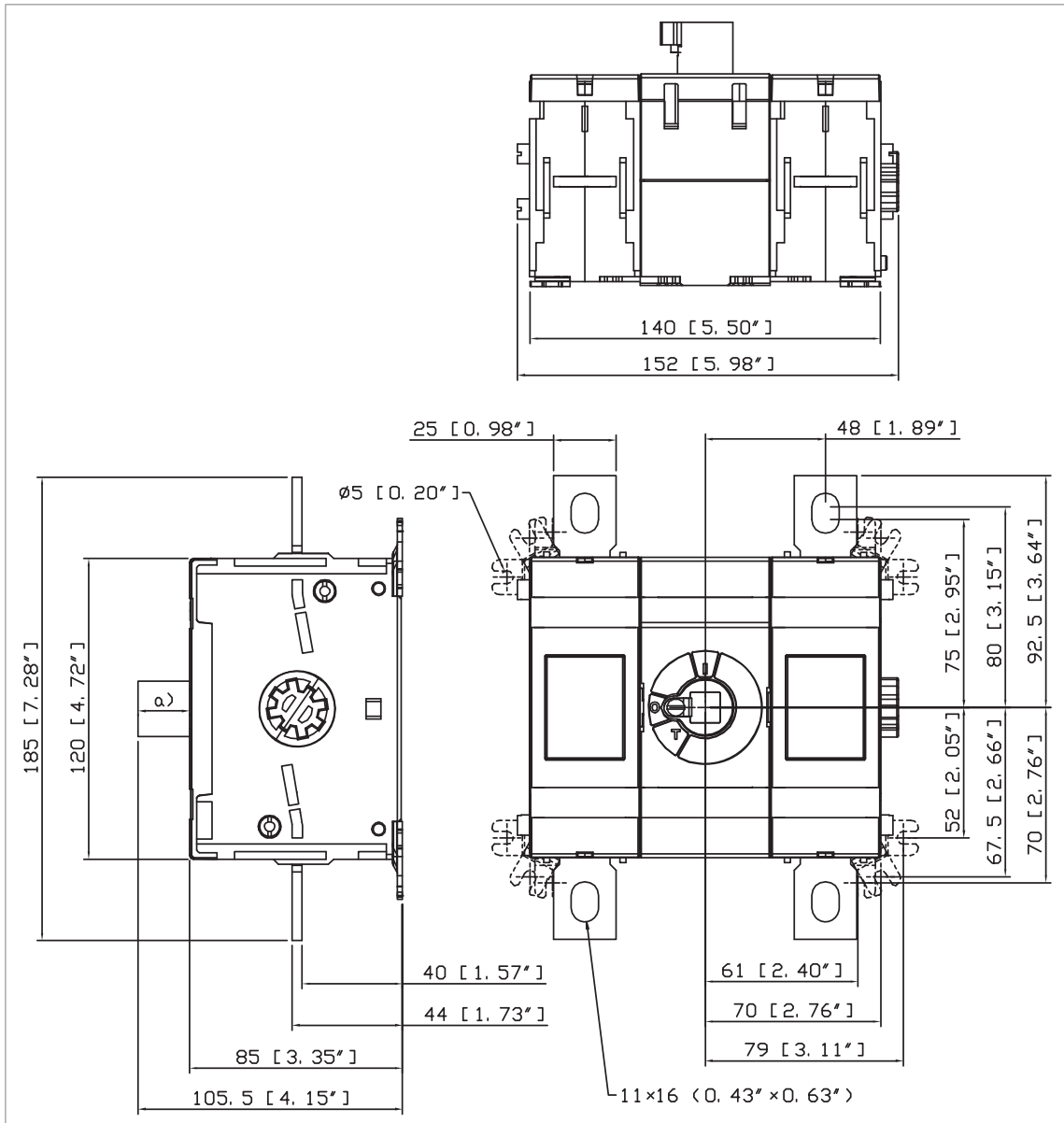

a) The shaft must extend into the switch at least 20 mm (0.79").

OT400E22

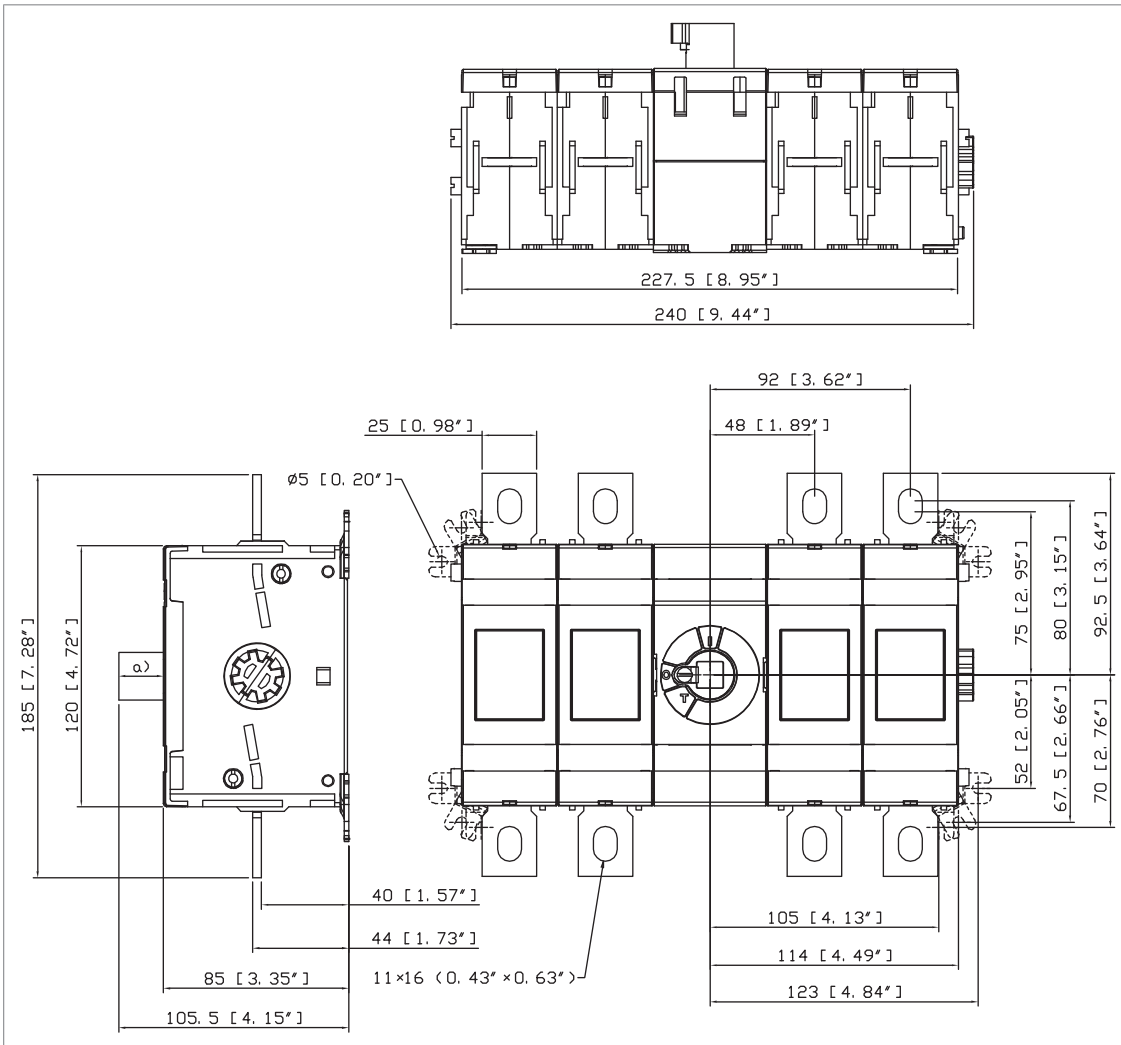

a) The shaft must extend into the switch at least 20 mm (0.79").

OT400U11

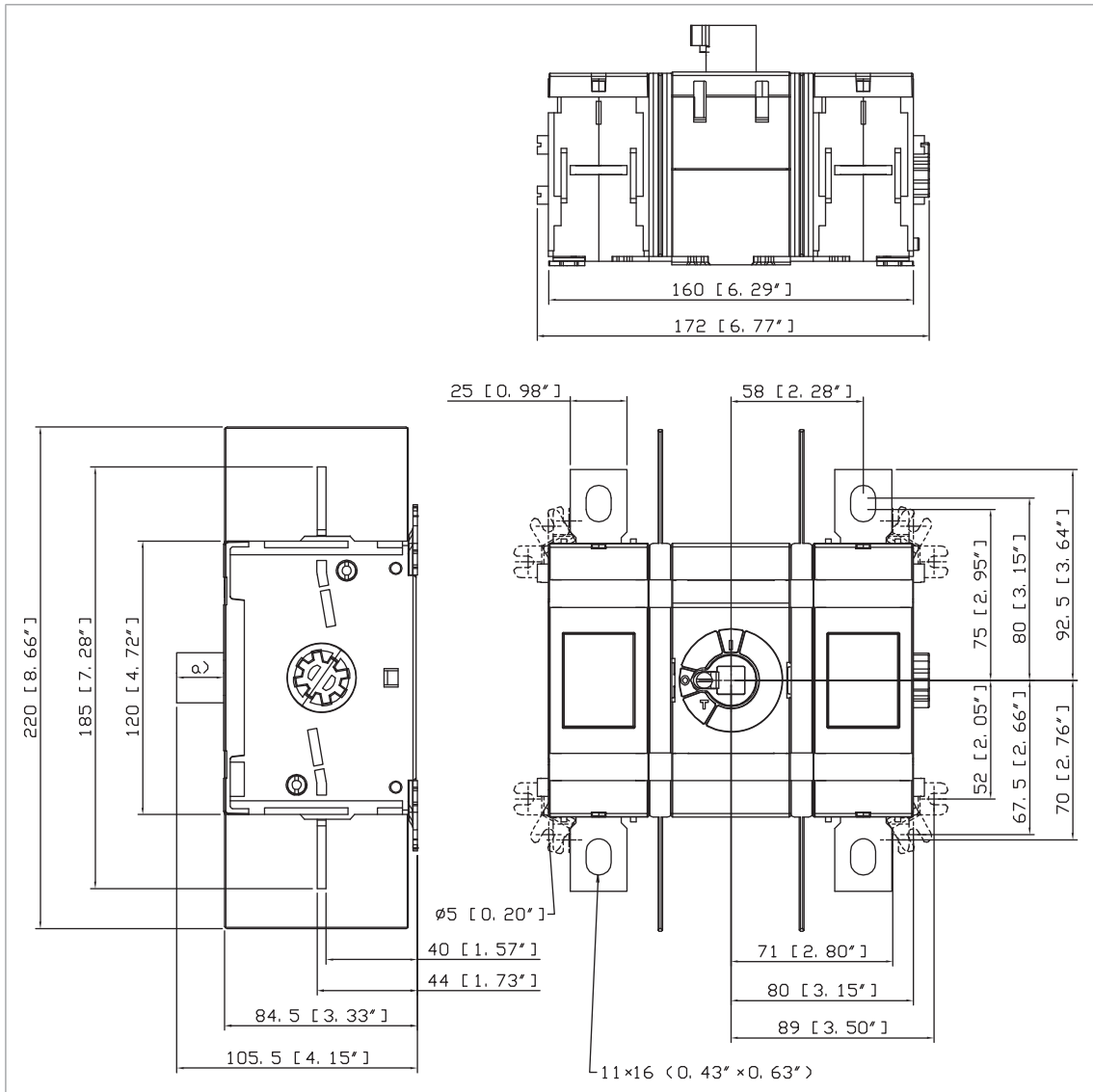

a) The shaft must extend into the switch at least 20 mm (0.79").

OT400U22

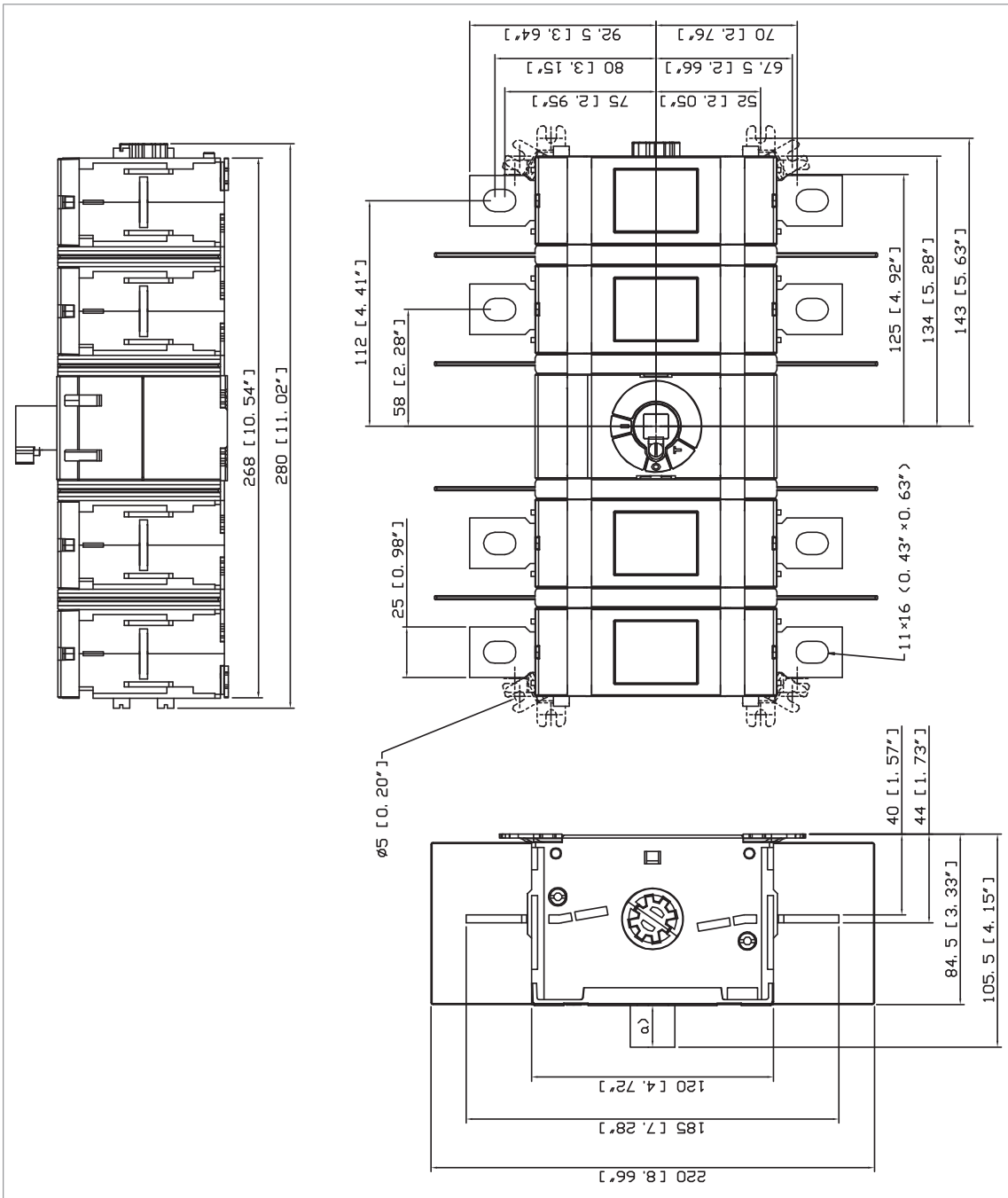

a) The shaft must extend into the switch at least 20 mm (0.79").

OT600U11, OT630E11

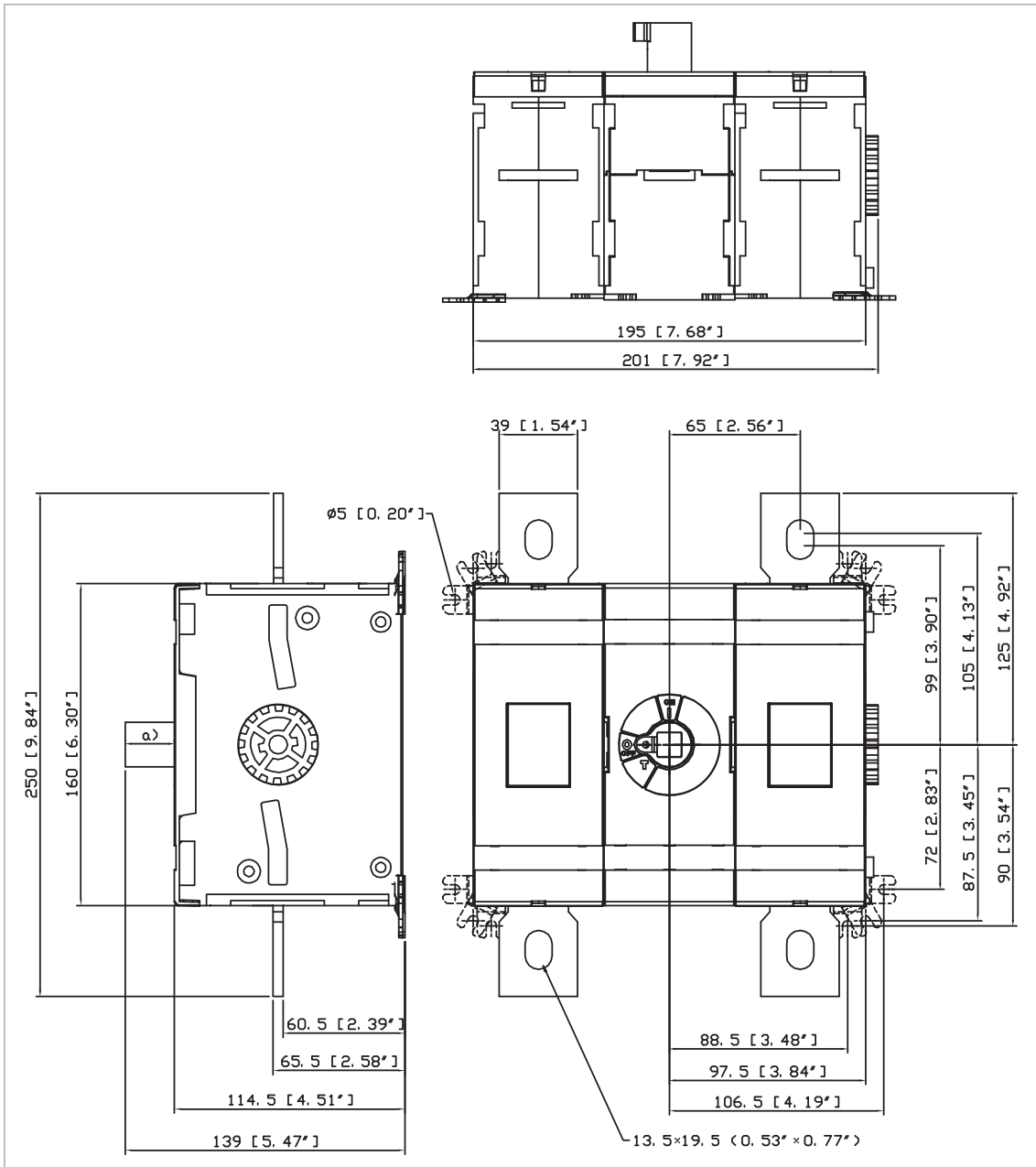

a) The shaft must extend into the switch at least 20 mm (0.79").

OT1200U_, OT1600E_

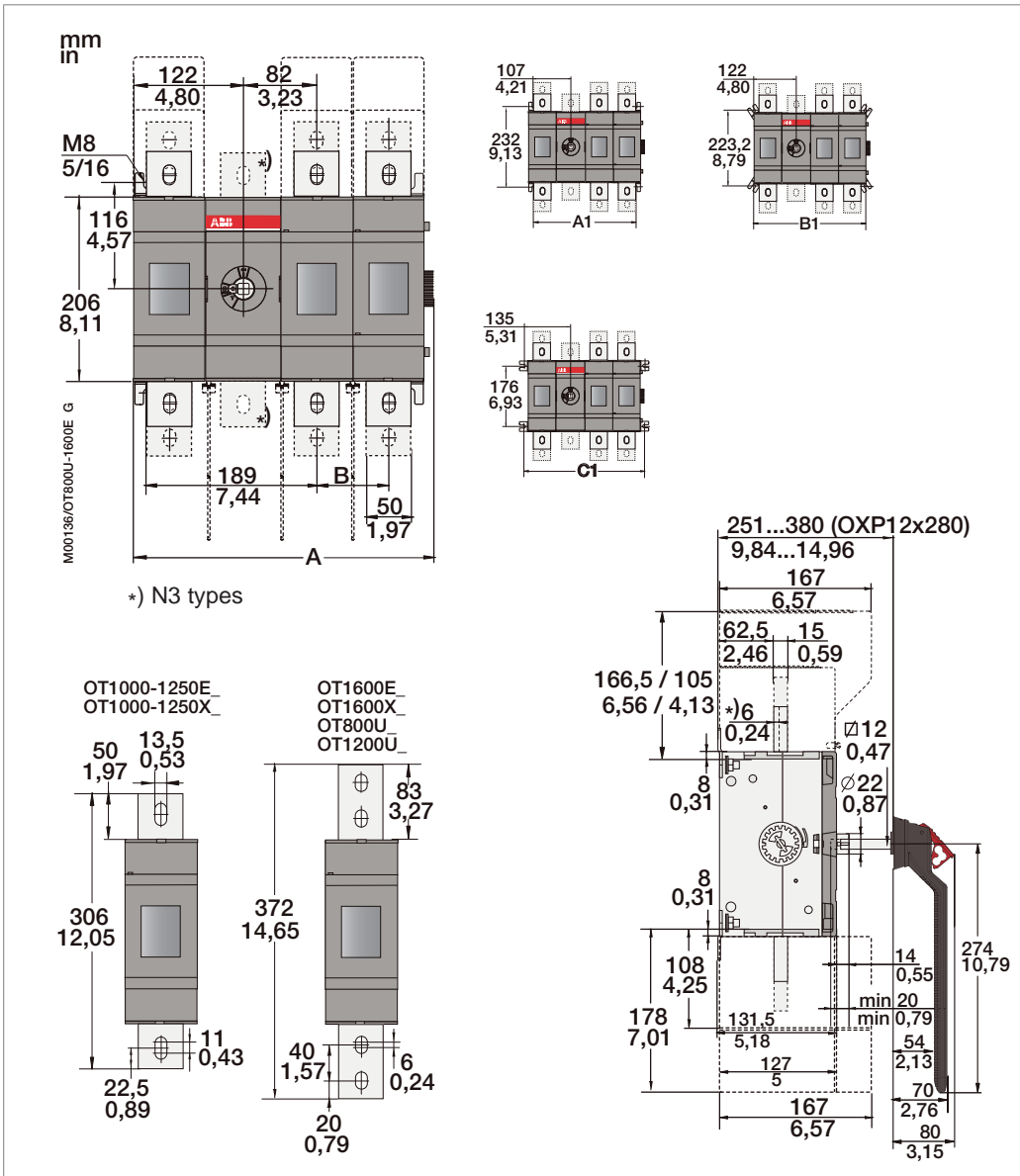

	_11 mm (in)	_22 mm (in)
A	254.50 (10.02)	414.50 (16.32)
B	-	80 (3.15)
A1	214 (8.43)	374 (14.72)
B1	244 (9.61)	404 (15.91)
C1	270 (10.63)	430 (16.93)

OT2500E22

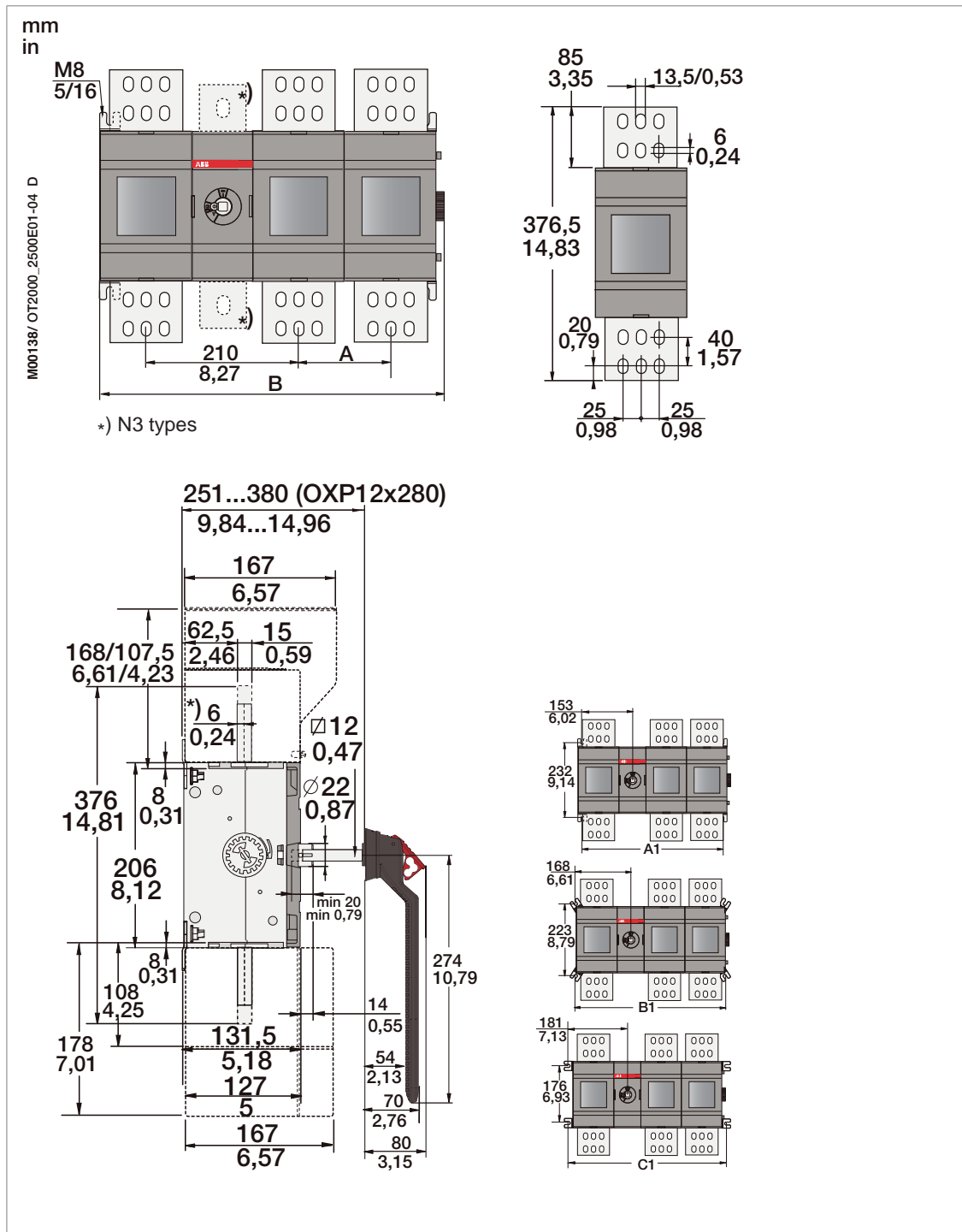

	mm (in)
A	126 (4.96)
B	598.5 (23.56)
A1	558 (21.97)
B1	588 (23.15)
C1	614 (24.17)

■ **OHB_ switch handles**

Note: The drawings are not to scale.

OHB65J6, OHB125J12, OHB145J12

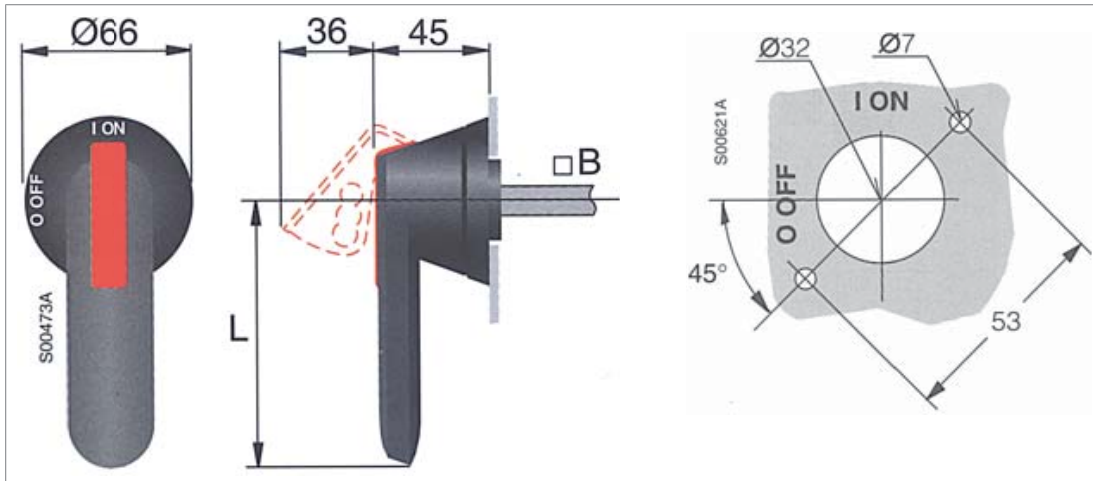

Handle type	L mm (in)	B mm (in)	Notes
OHB65J6	65 (2.56)	6 × 6 (0.24 × 0.24)	Used with OS_, OT200_
OHB125J12	125 (4.92)	12 × 12 (0.47 × 0.47)	Used with OT400_
OHB145J12	145 (5.71)	12 × 12 (0.47 × 0.47)	Used with OT600_ and OT630_

OHB150J12P

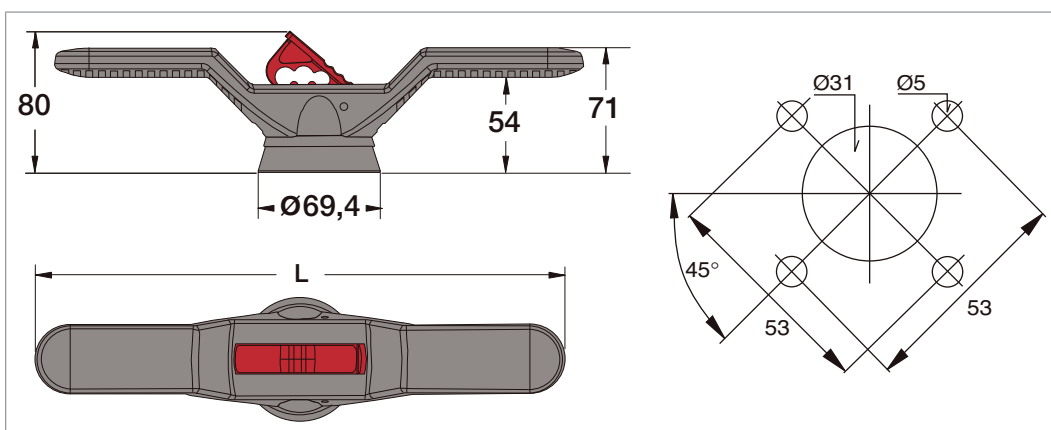

Handle type	L mm (in)	Shaft mm (in)	Notes
OHB150J12P	300 (11.81)	12 × 12 (0.47 × 0.47)	Used with OT1200U11 and OT1600E11

OHB274J12

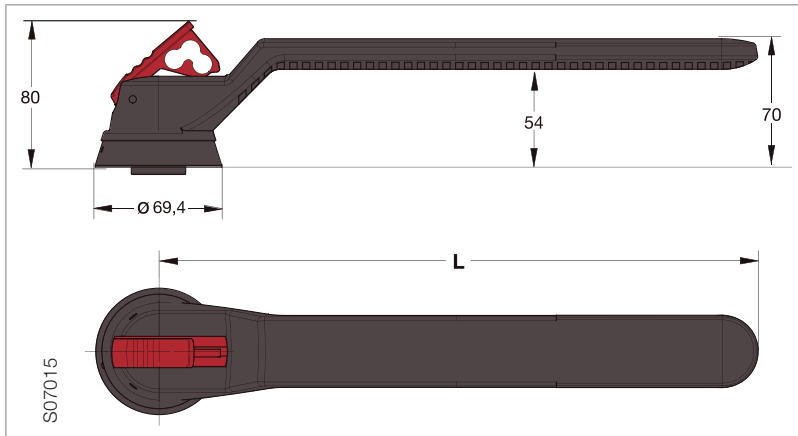

The drilling pattern is the same as OHB65/125/145.

Handle type	L mm (in)	Shaft mm (in)	Note
OHB274J12	274 (10.79)	12 × 12 (0.47 × 0.47)	Used with OT1200U22, OT1600E22 and OT2500E22

■ **OA1G10/OA3G01 auxiliary contact blocks**

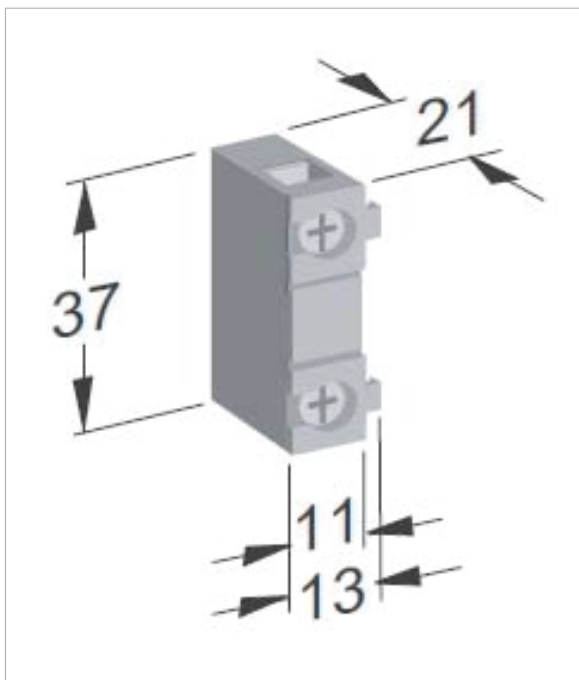

2×0.75...2.5 mm² (2×18...14 AWG)

0.8 N·m (7 lbf·in)

Pozidriv M3.5 Form 2

■ AF190-30-00-13 contactor

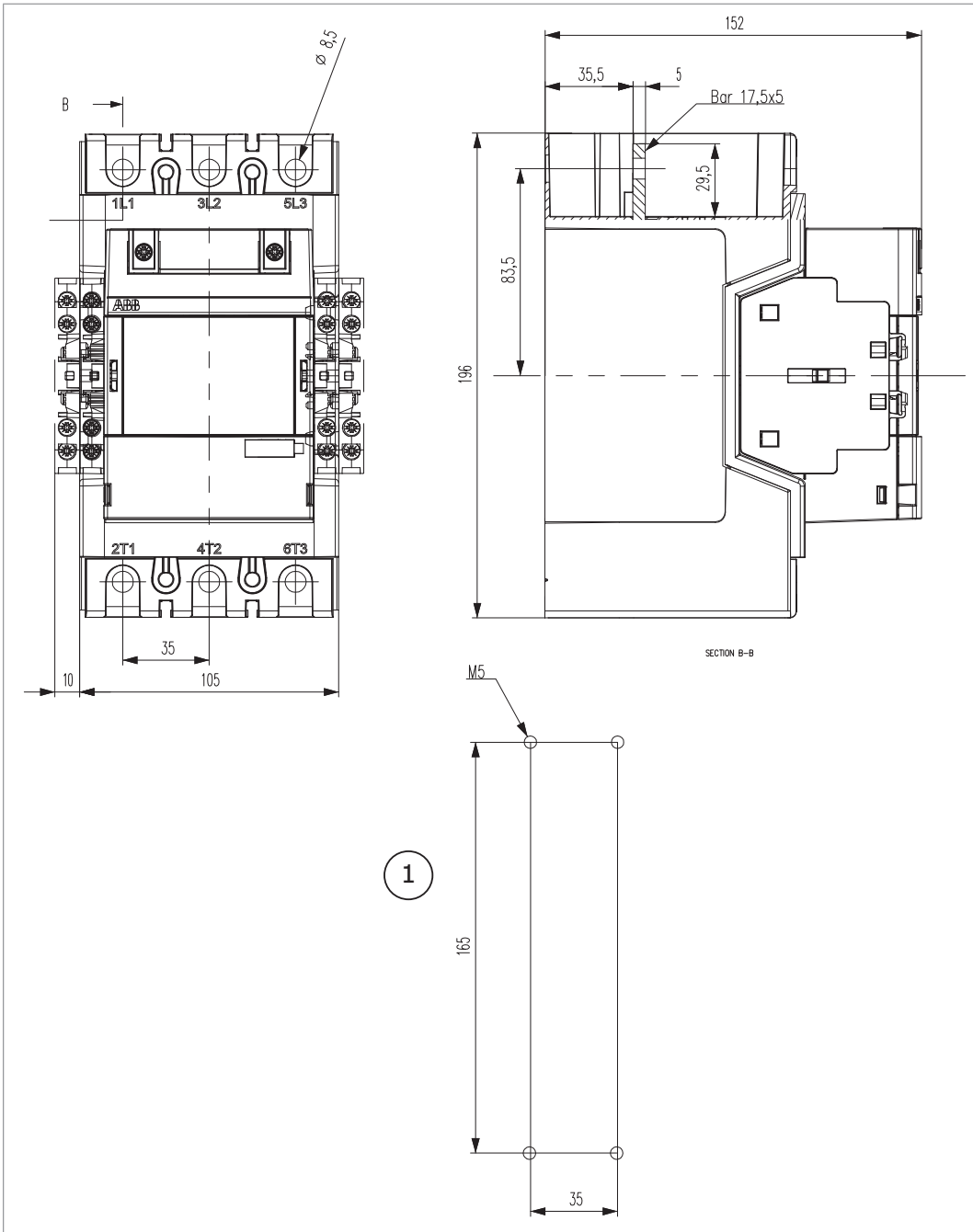

1. Drilling pattern

■ Charging controller

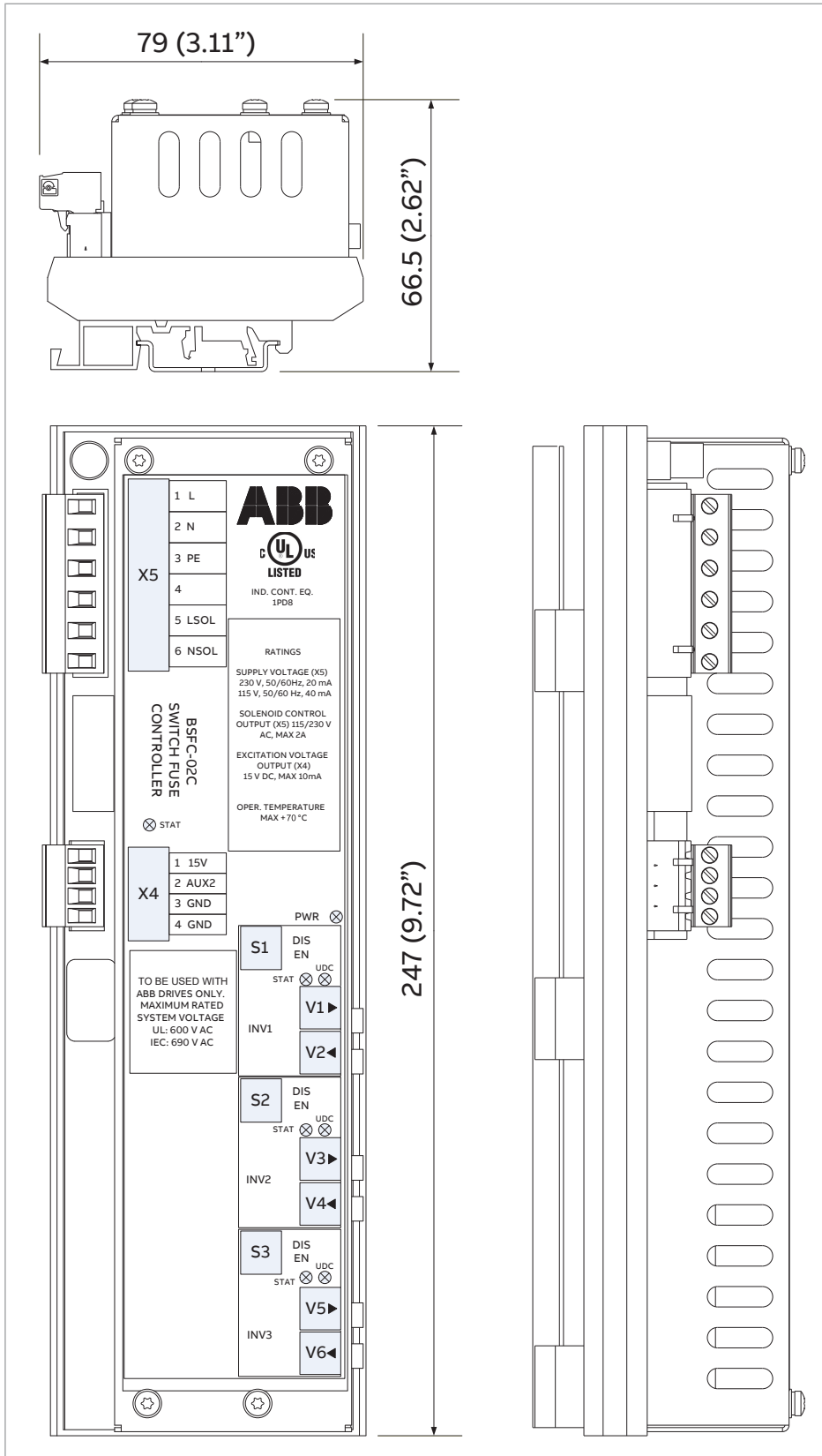

■ **Charging resistor (frame R7i)**

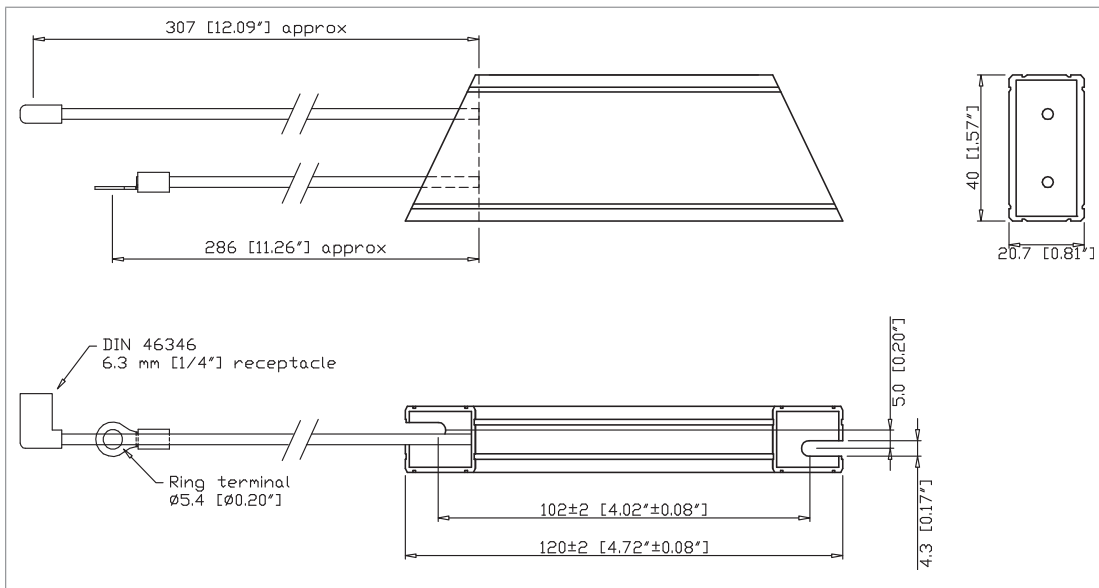

■ **Charging resistor (frame R8i)**

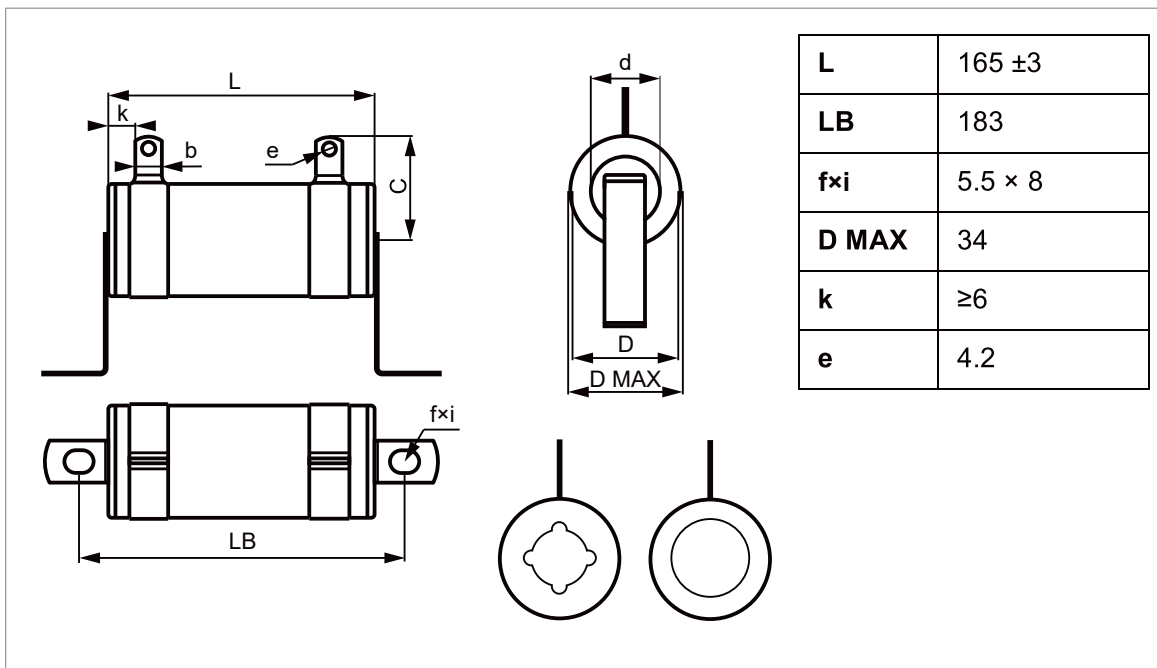

Miscellaneous components

■ Cooling fan 3AXD500000592

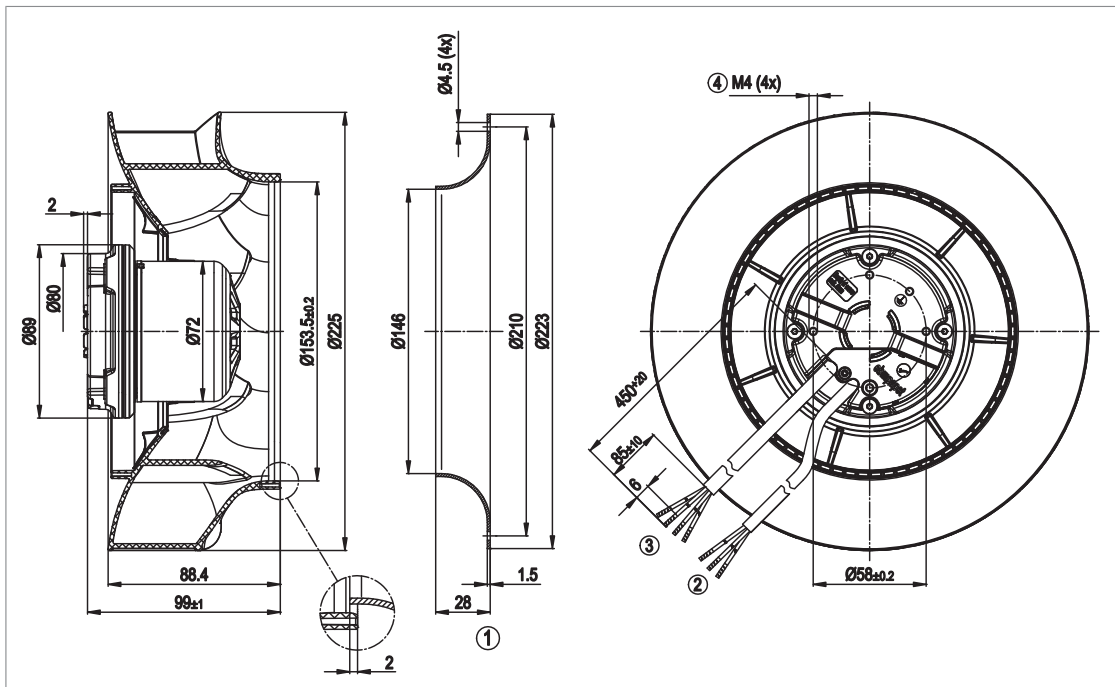

■ Cooling fan 3AXD5000006111

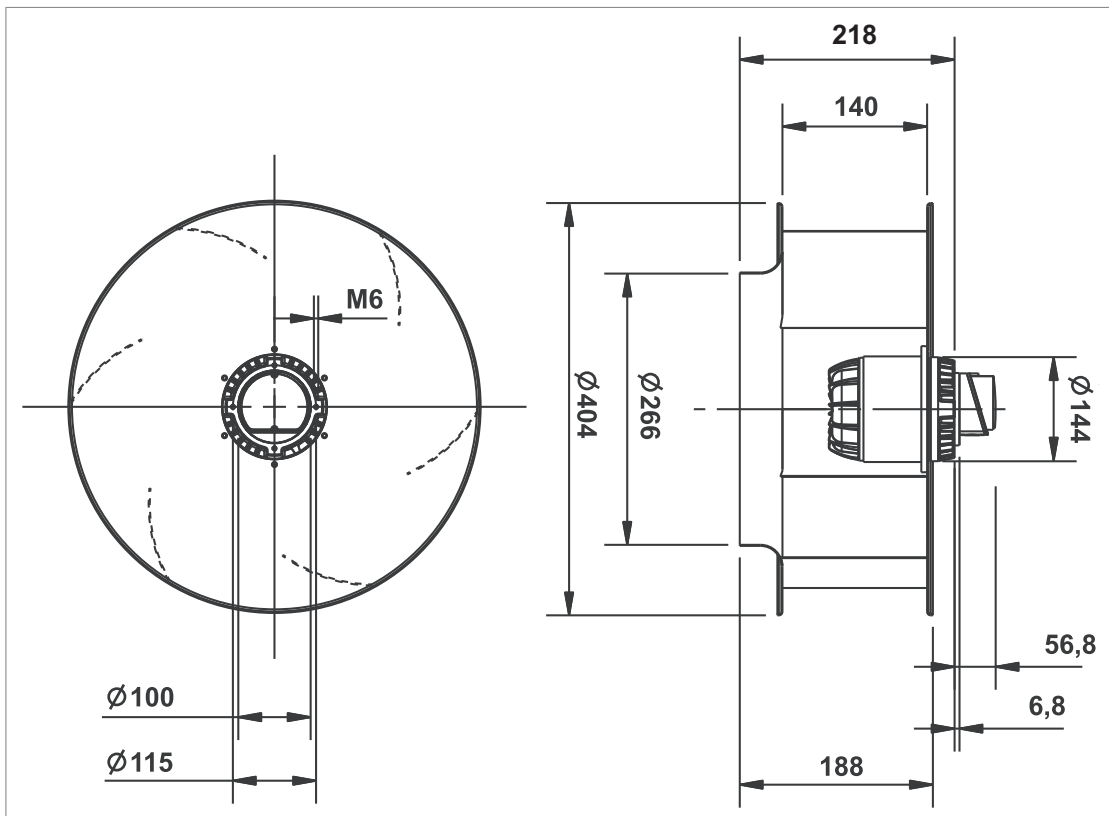

■ Output (du/dt) filters for frames R1i...R5i

L2	mm (inch)						① ② ∅	kg /1	⑤	① ② Nm	③ ④	Nm
	A	B	C	D	E	H	mm (inch)	kg (lb)		N-m (lbf-in)	mm ²	N-m (lbf-in)
NOCH0016-60	140 (5.51)	195 (7.68)	120 (4.72)	85 (3.35)	115 (4.53)	83 (3.279)	-	2.4 (5.29)	M5	4 (35.40)	0.2...10	1.5 (13.28)
NOCH0030-60	165 (6.50)	215 (8.46)	145 (5.71)	108 (4.25)	130 (5.12)	95 (3.74)	-	4.7 (10.36)	M5	4 (35.40)	0.5...16	1.5 (13.28)
NOCH0070-60	180 (7.09)	261 (10.28)	170 (6.69)	125 (4.92)	150 (5.91)	120 (4.72)	-	9.5 (20.94)	M6	6 (53.10)	10...35	2.5 (22.13)
NOCH0120-60	154 (6.06)	106 (4.17)	100 (3.94)	75 (2.95)	200 (7.87)	160 (6.30)	9 (0.35)	7 (15.43)	M8	20 (177.02)	-	-
NOCH0260-60	185 (7.28)	111 (4.37)	124 (4.88)	82 (3.23)	383 (15.08)	368 (14.49)	13 (0.51)	12 (26.46)	M10	30 (265.52)	-	-
NOCH0400-60	185 (7.28)	126 (4.96)	124 (4.88)	97 (3.82)	383 (15.08)	368 (14.49)	13 (0.51)	17 (37.48)	M10	30 (265.52)	-	-

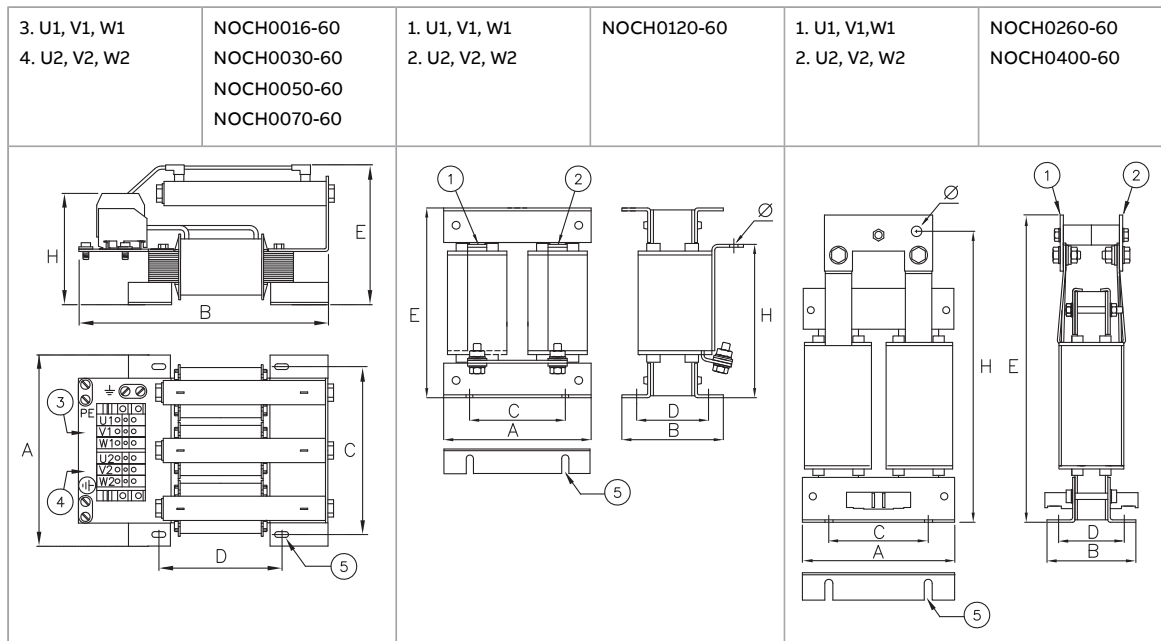

■ **Common mode filters**

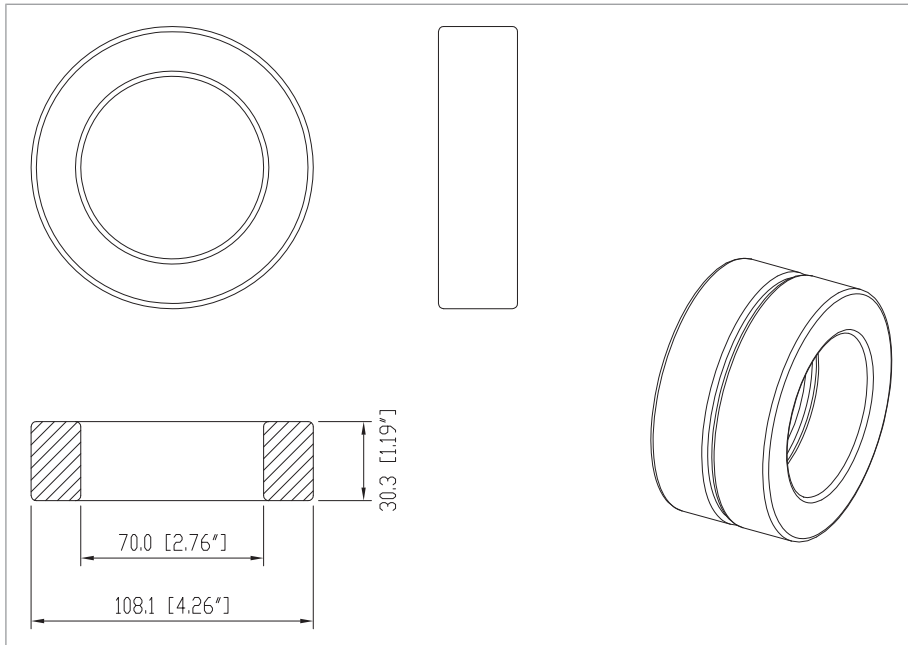

■ **Quick connector for frame R8i**

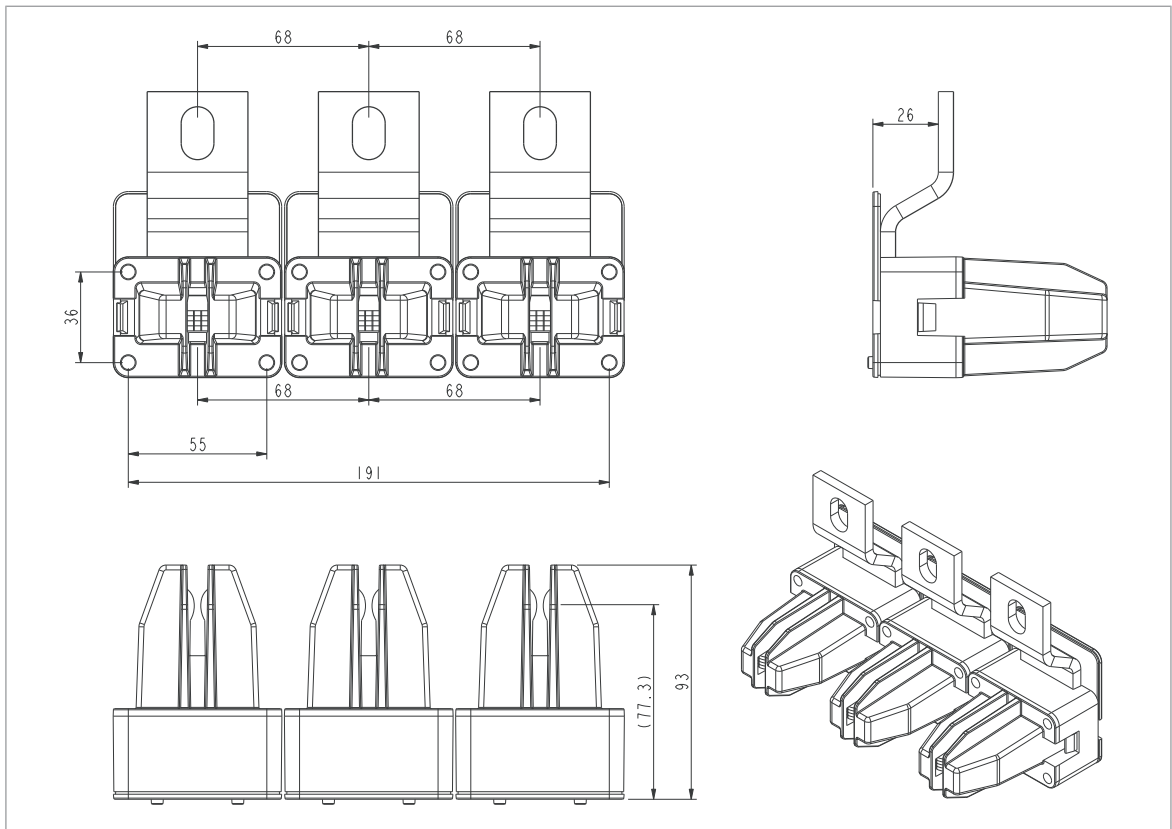

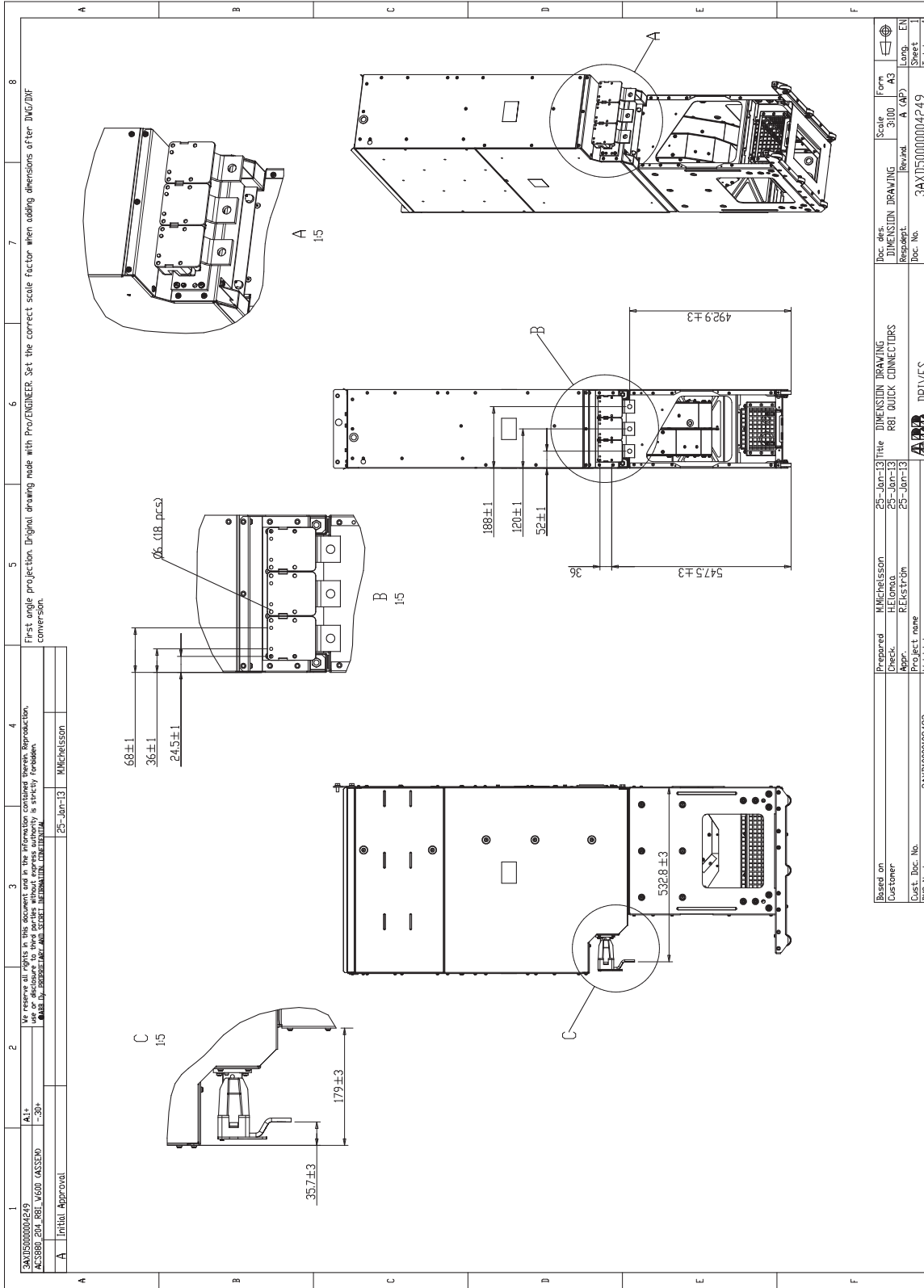

First angle projection. Digital drawing made with Pro/ENGINEER. Set the correct scale factor when adding dimensions after DWG/DXF conversion.

1	3	4	5	6	7	8
We reserve all rights in this document and in the information contained therein. Reproduction, distribution, or disclosure of this document or its contents without the written permission of ABB is strictly forbidden.						
Prepared by: MICHELSSON Checked by: HELGREN Approved by: REJSTRÖM						
Date: 25-Jan-13 Designer: MICHELSSON						

Based on	Customer	Customer	Customer	Customer	Customer	Customer
3AXD5000004249	R81 V600 CASSEPO	A1+	AC5880_204_R81_V600	AC5880_204_R81_V600	AC5880_204_R81_V600	AC5880_204_R81_V600
Initial Approval						
Prepared by: MICHELSSON Checked by: HELGREN Approved by: REJSTRÖM						
Date: 25-Jan-13 Designer: MICHELSSON						
Project name: R81 QUICK CONNECTORS Project no.: 3AXD5000004249 Weight: kg						
DIMS Number: 3AXD5000004249						
Scale: 3:100 Paper: A3 Format: A (A3) Drawing: DIMENSION DRAWING Revision: A (A3) Description: R81 QUICK CONNECTORS Doc. No.: 3AXD5000004249						
						Loop: EN Sheet: 1 Total: 1

470 Dimension drawings

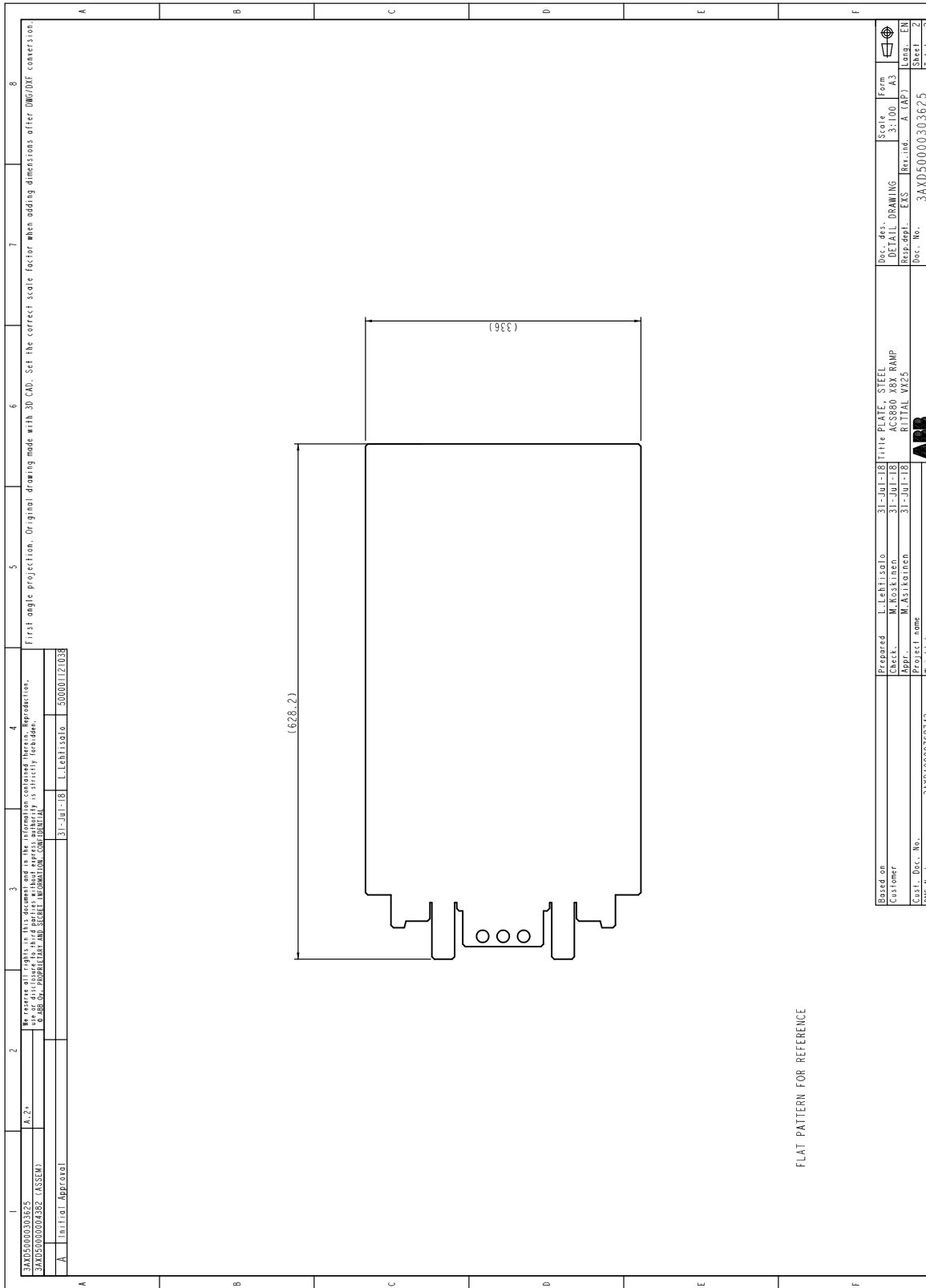

16

Circuit diagrams

Contents of this chapter

This chapter contains connection diagram examples for the whole inverter unit.

Note: By default, the Safe torque off (STO) function is not in use, and has been bridged at the factory as shown in the diagrams. For information on implementing the function, see chapter [The Safe torque off function \(page 389\)](#).

Note: This chapter does not contain all the circuit diagrams for all frame sizes. For complete set of diagrams, refer to the circuit diagrams delivered with the drive.

Component designations used in the diagrams

■ Frames R1i...R5i

Designation	Component
A41.x	ZCU control unit
A47	FDPI diagnostics and control panel interface. For constructing a panel bus between inverter modules without front cover, see Panel bus (control of several units from one control panel) (page 200) .
A48	DPMP-01 panel mounting platform kit (to be ordered separately)
A49	ACS-AP-W control panel
F10.x	Main DC fuses
F11.x	Module-specific DC fuses
G26.x	Roof fan
K26	Roof fan control relay

472 Circuit diagrams

Designation	Component
Q11	Main DC switch/disconnector
R12	du/dt filter
T11	Inverter module
T22	24 V DC power supply

■ Frame R6i

Designation	Component
A41	Control unit
A47	FDPI diagnostics and control panel interface. For constructing a panel bus between inverter modules without front cover, see Panel bus (control of several units from one control panel) (page 200) .
A48	DPMP-01 panel mounting platform kit (to be ordered separately)
A49	ACS-AP-W control panel
F11.x	DC fuses
Q11	Main DC switch/disconnector
R12	Output (du/dt) filter
T11	Inverter module
T22	24 V DC power supply
Z1.x	Common mode filters

■ Frame R7i

Designation	Component
A47	FDPI diagnostics and control panel interface. For constructing a panel bus between inverter modules without front cover, see Panel bus (control of several units from one control panel) (page 200) .
A48	DPMP-01 panel mounting platform kit (to be ordered separately)
A49	ACS-AP-W control panel
A51	Control unit
F11.x	DC fuses
Q11	Main DC switch/disconnector
Q14	Charging contactor
R14.x	Charging resistors
T11	Inverter module
T22	24 V DC power supply
Z1.x	Common mode filters

■ Frame R8i and multiples

Designation	Component
A11.x	Charging controller
A41	Control unit
A47	FDPI diagnostics and control panel interface. For constructing a panel bus between inverter modules without front cover, see Panel bus (control of several units from one control panel) (page 200) .
A48	DPMP-01 panel mounting platform kit (to be ordered separately)
A49	ACS-AP-W control panel
F11.xx	DC fuses
Q10.x	Charging switch
Q11.x	Main DC switch/disconnector
R10.x	Charging resistors
R11.xx	Common mode filters
T11.x	Inverter module
T22	External 24 V DC power supply

Frames R1i...R4i

■ Frames R1i...R4i – Sheet 000A

					
Project type	Example Circuit Diagrams				
Converter type	ACS880-104 Inverter Unit				
Frame Size	R2i (IEC)				
Type Code	ACS880-104-0014A-5				
Revision	Revision F				
Customer	Example Circuit Diagrams				
Title	Title page / cover sheet				
Date	15.03.2023				
Author	Mika Asikainen				
Project	ACS880-104 R2i (IEC)				
SAP Doc. No.	DMS Doc. No. 3AXD10000615732				
EPLAN Doc. No.	3AFE				
Rev.	F				
Sheet	000A				
No. of Sheets	5				

RD143981 / 4181Used EPLAN version: 2.3.19491

■ Frames R1i...R4i – Sheet 000B

1	2	3	4	5	6	7	8	
Higher-level function	Page	Page description					Revision	
	000A	Title page / cover sheet					F	
	000C	Structured identifier overview					F	
	000D	Summarized parts list					F	
	300A	Symbol Overview					F	
	11	001a	MAIN CIRCUIT					F
		003a	MAIN CIRCUIT					F
		020a	AUXILIARY VOLTAGE DISTRIBUTION					F
		021a	AUXILIARY VOLTAGE DISTRIBUTION					F
		026a	CABINET FAN CONTROL ZCU					F
		040a	CONTROL BOARD					F
040b		CONTROL BOARD					F	
040c	CONTROL BOARD					F		
040d	CONTROL BOARD					F		
041a	OPTION CARDS					F		
061a	SAFETY CIRCUIT					F		
ABB								
Customer: Example Circuit Diagrams		Prep. Oleg Vanin	15.03.2023		Title Table of contents		Item Dis.	
		App. Mika Asikainen	23.03.2023				=	
		Project ACS800-104			SAP Doc. No. DIMS Doc. No. 3AXD10000615732		+	
		R21 (IEC)			EPAN Doc. No. 3AFE		-	
					ABB Ref. No.		Rev.	
					Resp. Dept.		F Sheet	
							No. of Sheets	
							5	
							8	
RD143981 / 4181								

■ Frames R1i...R4i – Sheet 300A

	1	2	3	4	5	6	7	8
A	GENERAL/RELAY COIL WITH PROTECTIVE CIRCUIT DIODE AND R-LED		NO SWITCH, OPERATED BY TURNING, 2 POSITIONS		PROTECTIVE EARTH CONNECTED TO FRAME		TERMINAL FOUR POLE	
B	GENERAL/RELAY COIL		LIMIT SWITCH NC CONTACT MECHANICALLY OPERATED		PROTECTIVE EARTH CONNECTED TO TERMINAL / PE BUSBAR		PLUG AND SOCKET TERMINAL BLOCK WITH 4 CONNECTION POINTS	
C	COIL WITH PICK-UP DELAY		NC SWITCH, TEMPERATURE OPERATED		FUNCTIONAL EARTHING CONNECTED TO TERMINAL		FEMALE AND MALE PLUG	
D	COIL WITH OFF-DELAY		EMERGENCY STOP PUSH BUTTON		FUNCTIONAL BONDING TO FRAME		AMPERE METER	
E	NO CONTACT		DISCONNECT SWITCH, THREE-POLE		LIGHT		CURRENT TRANSFORMER	
F	NC CONTACT		SWITCH DISCONNECTOR WITH FUSES, THREE-POLE		INDUCTOR		VOLTAGE METER	
G	CHANGE OVER CONTACT		FUSE		CAPACITOR		WIRE TERMINATION, INSULATED	
H	NO CONTACT, WITH CLOSING DELAY		FUSE DISCONNECTOR		RESISTOR		SHIELDED CABLE	
I	TWO NO CONTACTS ONE INPUT, TWO OUTPUTS		CIRCUIT BREAKER		POWER RESISTOR WITH FUSE			
J	TWO CONNECTED CHANGE OVER CONTACTS		MOTOR OVERLOAD SWITCH WITH SWITCH MECHANISM		PHASE SELECTING SWITCH			
K	POWER NO CONTACT OF A CONTACTOR		COMMON MODE FILTER FOR HIGH FREQUENCY CURRENTS		TRANSFORMER		PHASE SELECTING SWITCH	
L	PUSH BUTTON WITH NO CONTACT				EMC FILTER		PHASE SELECTING SWITCH	
M	PUSH BUTTON WITH NC CONTACT						PHASE SELECTING SWITCH	
N							PHASE SELECTING SWITCH	
O							PHASE SELECTING SWITCH	
P							PHASE SELECTING SWITCH	
Q							PHASE SELECTING SWITCH	
R							PHASE SELECTING SWITCH	
S							PHASE SELECTING SWITCH	
T							PHASE SELECTING SWITCH	
U							PHASE SELECTING SWITCH	
V							PHASE SELECTING SWITCH	
W							PHASE SELECTING SWITCH	
X							PHASE SELECTING SWITCH	
Y							PHASE SELECTING SWITCH	
Z							PHASE SELECTING SWITCH	
AA							PHASE SELECTING SWITCH	
AB							PHASE SELECTING SWITCH	
AC							PHASE SELECTING SWITCH	
AD							PHASE SELECTING SWITCH	
AE							PHASE SELECTING SWITCH	
AF							PHASE SELECTING SWITCH	
AG							PHASE SELECTING SWITCH	
AH							PHASE SELECTING SWITCH	
AI							PHASE SELECTING SWITCH	
AJ							PHASE SELECTING SWITCH	
AK							PHASE SELECTING SWITCH	
AL							PHASE SELECTING SWITCH	
AM							PHASE SELECTING SWITCH	
AN							PHASE SELECTING SWITCH	
AO							PHASE SELECTING SWITCH	
AP							PHASE SELECTING SWITCH	
AQ							PHASE SELECTING SWITCH	
AR							PHASE SELECTING SWITCH	
AS							PHASE SELECTING SWITCH	
AT							PHASE SELECTING SWITCH	
AU							PHASE SELECTING SWITCH	
AV							PHASE SELECTING SWITCH	
AW							PHASE SELECTING SWITCH	
AX							PHASE SELECTING SWITCH	
AY							PHASE SELECTING SWITCH	
AZ							PHASE SELECTING SWITCH	
BA							PHASE SELECTING SWITCH	
BB							PHASE SELECTING SWITCH	
BC							PHASE SELECTING SWITCH	
BD							PHASE SELECTING SWITCH	
BE							PHASE SELECTING SWITCH	
BF							PHASE SELECTING SWITCH	
BG							PHASE SELECTING SWITCH	
BH							PHASE SELECTING SWITCH	
BI							PHASE SELECTING SWITCH	
BJ							PHASE SELECTING SWITCH	
BK							PHASE SELECTING SWITCH	
BL							PHASE SELECTING SWITCH	
BM							PHASE SELECTING SWITCH	
BN							PHASE SELECTING SWITCH	
BO							PHASE SELECTING SWITCH	
BP							PHASE SELECTING SWITCH	
BQ							PHASE SELECTING SWITCH	
BR							PHASE SELECTING SWITCH	
BS							PHASE SELECTING SWITCH	
BT							PHASE SELECTING SWITCH	
BU							PHASE SELECTING SWITCH	
BV							PHASE SELECTING SWITCH	
BW							PHASE SELECTING SWITCH	
BX							PHASE SELECTING SWITCH	
BY							PHASE SELECTING SWITCH	
BZ							PHASE SELECTING SWITCH	
CA							PHASE SELECTING SWITCH	
CB							PHASE SELECTING SWITCH	
CC							PHASE SELECTING SWITCH	
CD							PHASE SELECTING SWITCH	
CE							PHASE SELECTING SWITCH	
CF							PHASE SELECTING SWITCH	
CG							PHASE SELECTING SWITCH	
CH							PHASE SELECTING SWITCH	
CI							PHASE SELECTING SWITCH	
CJ							PHASE SELECTING SWITCH	
CK							PHASE SELECTING SWITCH	
CL							PHASE SELECTING SWITCH	
CM							PHASE SELECTING SWITCH	
CN							PHASE SELECTING SWITCH	
CO							PHASE SELECTING SWITCH	
CP							PHASE SELECTING SWITCH	
CQ							PHASE SELECTING SWITCH	
CR							PHASE SELECTING SWITCH	
CS							PHASE SELECTING SWITCH	
CT							PHASE SELECTING SWITCH	
CU							PHASE SELECTING SWITCH	
CV							PHASE SELECTING SWITCH	
CW							PHASE SELECTING SWITCH	
CX							PHASE SELECTING SWITCH	
CY							PHASE SELECTING SWITCH	
CZ							PHASE SELECTING SWITCH	
DA							PHASE SELECTING SWITCH	
DB							PHASE SELECTING SWITCH	
DC							PHASE SELECTING SWITCH	
DD							PHASE SELECTING SWITCH	
DE							PHASE SELECTING SWITCH	
DF							PHASE SELECTING SWITCH	
DG							PHASE SELECTING SWITCH	
DH							PHASE SELECTING SWITCH	
DI							PHASE SELECTING SWITCH	
DJ							PHASE SELECTING SWITCH	
DK							PHASE SELECTING SWITCH	
DL							PHASE SELECTING SWITCH	
DM							PHASE SELECTING SWITCH	
DN							PHASE SELECTING SWITCH	
DO							PHASE SELECTING SWITCH	
DP							PHASE SELECTING SWITCH	
DQ							PHASE SELECTING SWITCH	
DR							PHASE SELECTING SWITCH	
DS							PHASE SELECTING SWITCH	
DT							PHASE SELECTING SWITCH	
DU							PHASE SELECTING SWITCH	
DV							PHASE SELECTING SWITCH	
DW							PHASE SELECTING SWITCH	
DX							PHASE SELECTING SWITCH	
DY							PHASE SELECTING SWITCH	
DZ							PHASE SELECTING SWITCH	
EA							PHASE SELECTING SWITCH	
EB							PHASE SELECTING SWITCH	
EC							PHASE SELECTING SWITCH	
ED							PHASE SELECTING SWITCH	
EE							PHASE SELECTING SWITCH	
EF							PHASE SELECTING SWITCH	
EG							PHASE SELECTING SWITCH	
EH							PHASE SELECTING SWITCH	
EI							PHASE SELECTING SWITCH	
EJ							PHASE SELECTING SWITCH	
EK							PHASE SELECTING SWITCH	
EL							PHASE SELECTING SWITCH	
EM							PHASE SELECTING SWITCH	
EN							PHASE SELECTING SWITCH	
EO							PHASE SELECTING SWITCH	
EP							PHASE SELECTING SWITCH	
EQ							PHASE SELECTING SWITCH	
ER							PHASE SELECTING SWITCH	
ES							PHASE SELECTING SWITCH	
ET							PHASE SELECTING SWITCH	
EU							PHASE SELECTING SWITCH	
EV							PHASE SELECTING SWITCH	
EW							PHASE SELECTING SWITCH	
EX							PHASE SELECTING SWITCH	
EY							PHASE SELECTING SWITCH	
EZ							PHASE SELECTING SWITCH	
FA							PHASE SELECTING SWITCH	
FB							PHASE SELECTING SWITCH	
FC							PHASE SELECTING SWITCH	
FD							PHASE SELECTING SWITCH	
FE							PHASE SELECTING SWITCH	
FF							PHASE SELECTING SWITCH	
FG							PHASE SELECTING SWITCH	
FH							PHASE SELECTING SWITCH	
FI								

■ Frames R1i...R4i – Sheet 001a

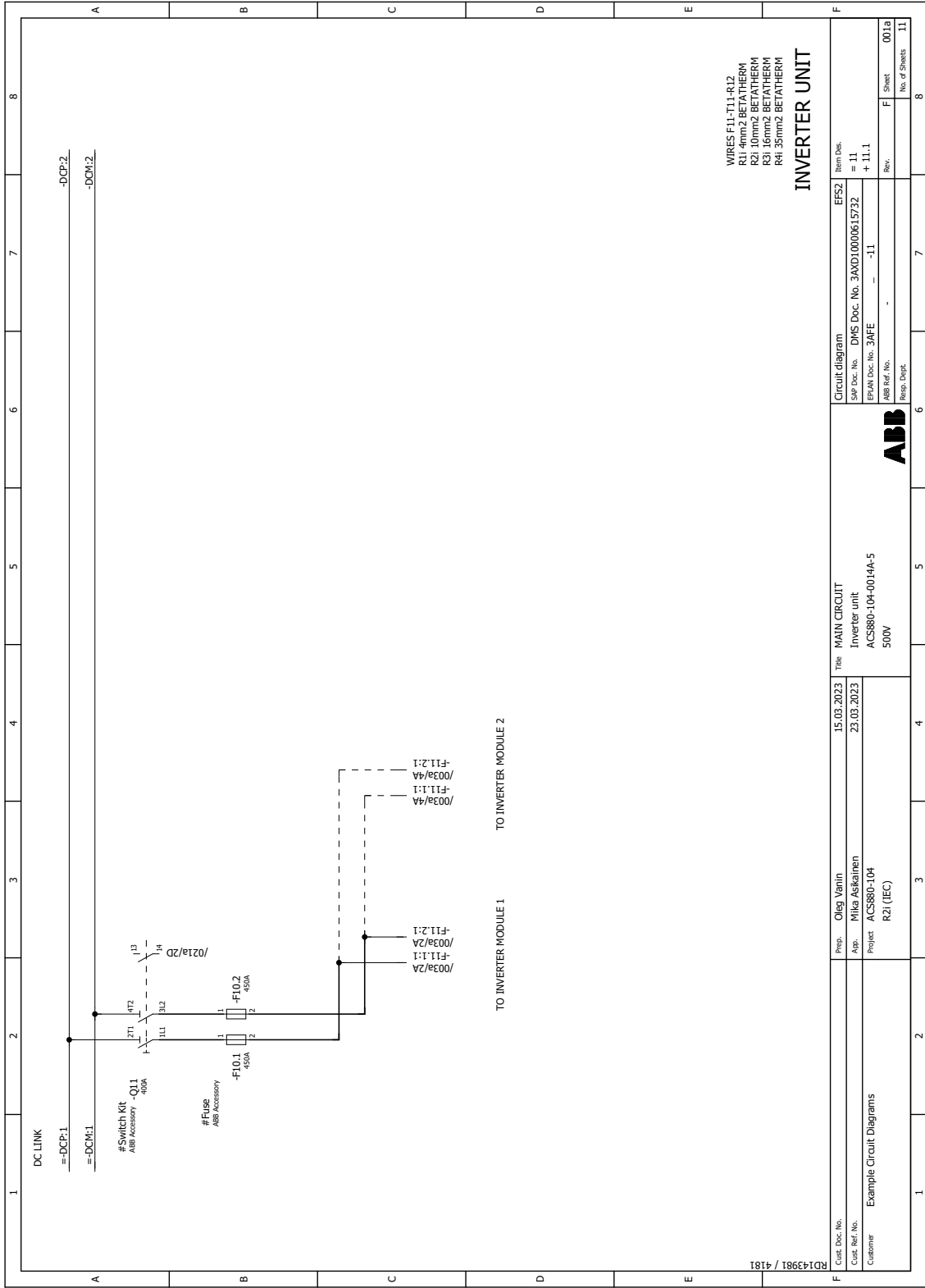

WIRES F11-T11-R12
 R11 4mm² BETATHERM
 R21 10mm² BETATHERM
 R31 16mm² BETATHERM
 R41 35mm² BETATHERM

INVERTER UNIT

RD143981 / 4181	Customer		Example Circuit Diagrams		Prep: Oleg Vanin		Date: 15.03.2023		Title: MAIN CIRCUIT		Circuit diagram		Item Desc:	
	Customer		Example Circuit Diagrams		App: Mika Askariainen		Date: 23.03.2023		Title: Inverter unit		SAP Doc. No.: DMS Doc. No.: 3AXD10000615732		= 11	
	Customer		Example Circuit Diagrams		Project: ACS880-104				ACS880-104-0014A-5		EPAN Doc. No.: 3AFE		+ 11.1	
	Customer		Example Circuit Diagrams		R21 (IEC)				500V		ABB Ref. No.:		Rev.:	
	Customer		Example Circuit Diagrams								Resp. Dept.:		F Sheet	
	Customer		Example Circuit Diagrams										001a	
	Customer		Example Circuit Diagrams										No. of Sheets	
	Customer		Example Circuit Diagrams										11	

■ Frames R1i...R4i – Sheet 003a

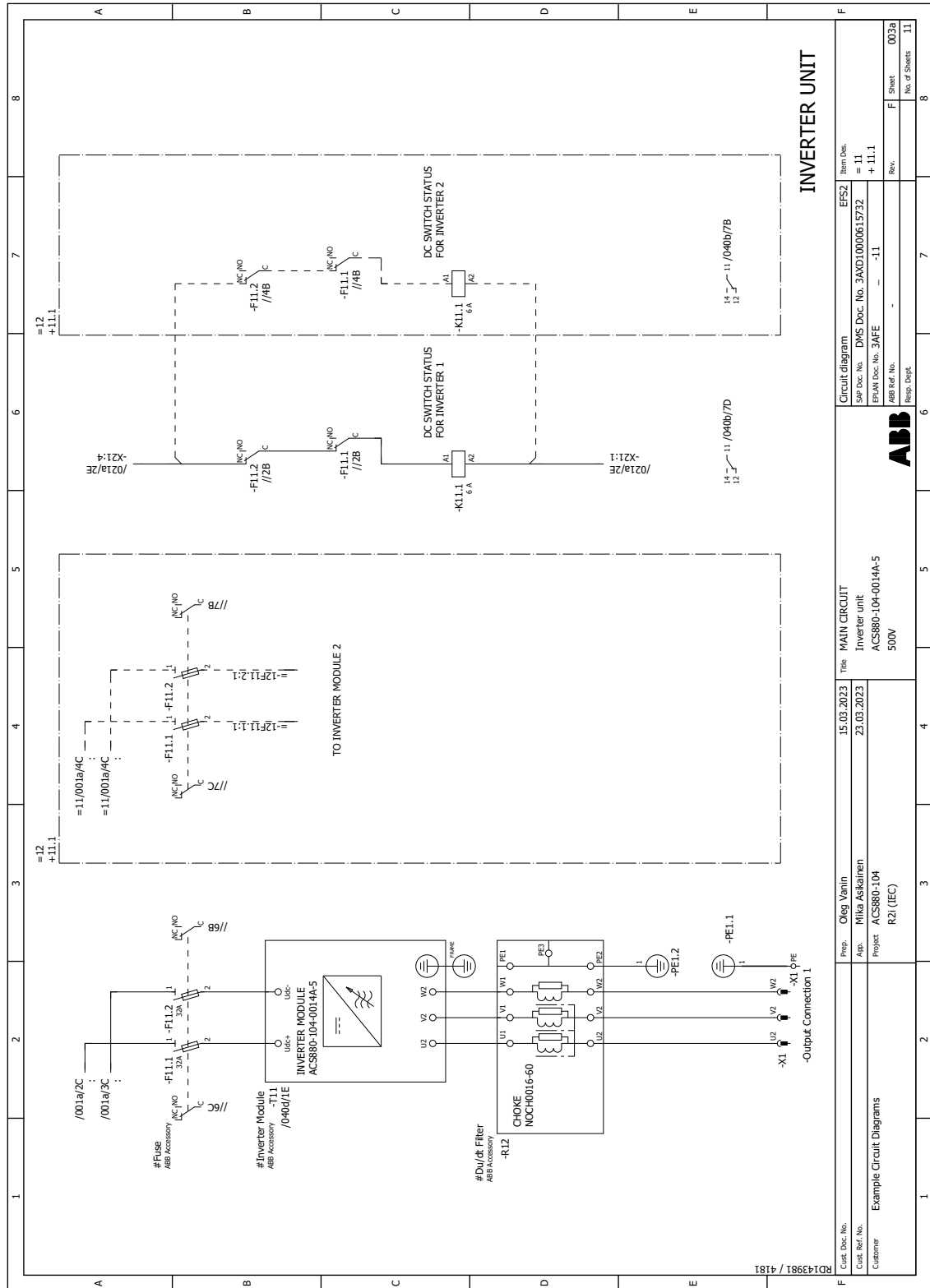

RD143981 / 4181

■ Frames R1i...R4i – Sheet 020a

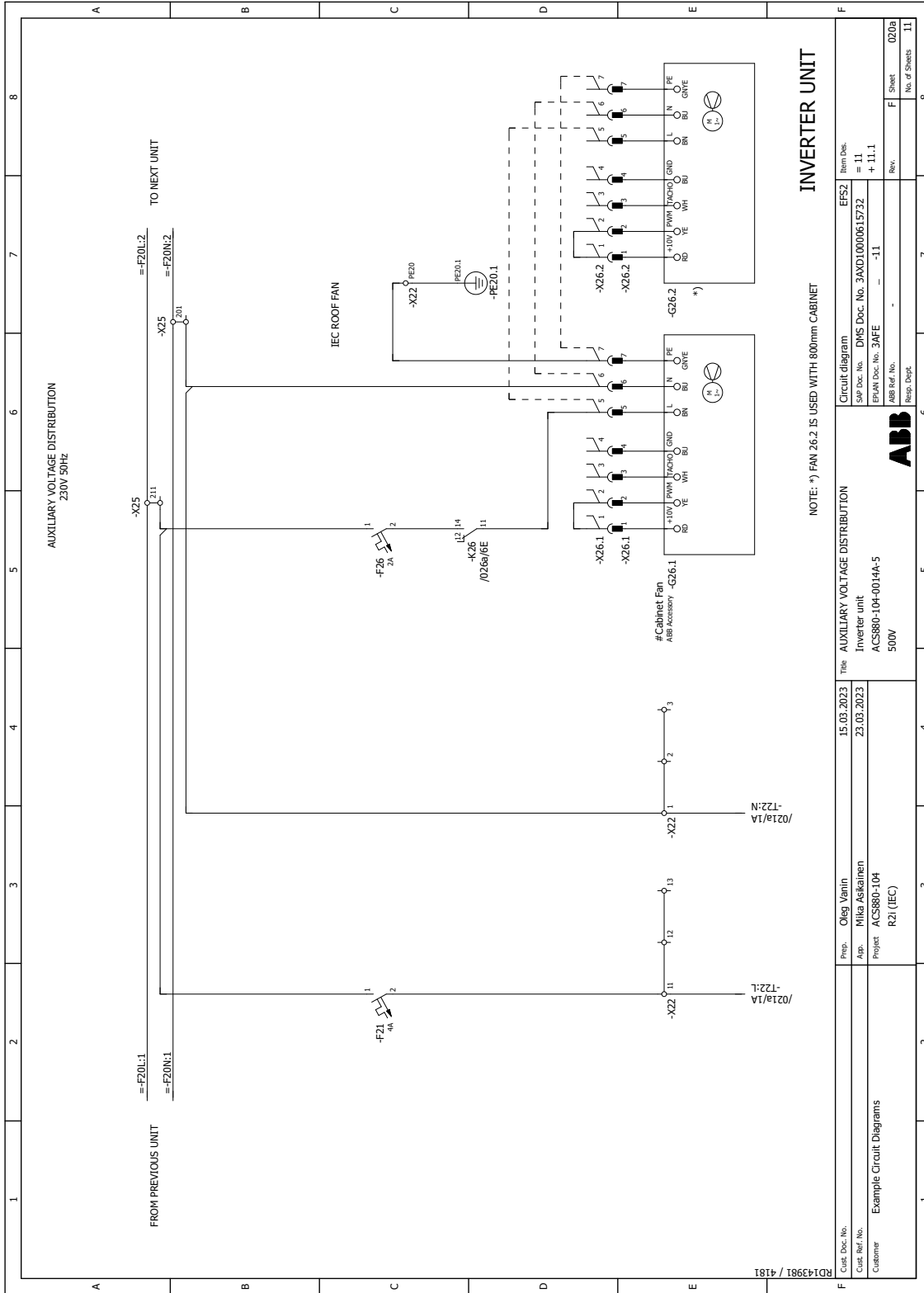

RD143981 / 4181		15.03.2023		15.03.2023		15.03.2023		15.03.2023	
Example Circuit Diagrams		Oleg Vanin		Mika Askariinen		Mika Askariinen		Mika Askariinen	
Customer		ACS880-104		R21 (IEC)		ACS880-104-0014A-5		500V	
Circuit diagram		EFS2		Item Des.		= 11		= 11.1	
SAP Doc. No.		DMS Doc. No.		3AXD10000615732		= 11		+ 11.1	
EPLAN Doc. No.		3AFE		-11		-11		-11	
ABB Ref. No.		-		-		-		-	
Resp. Dept.		-		-		-		-	
F		F		F		F		F	
11		11		11		11		11	

■ Frames R1i...R4i – Sheet 021a

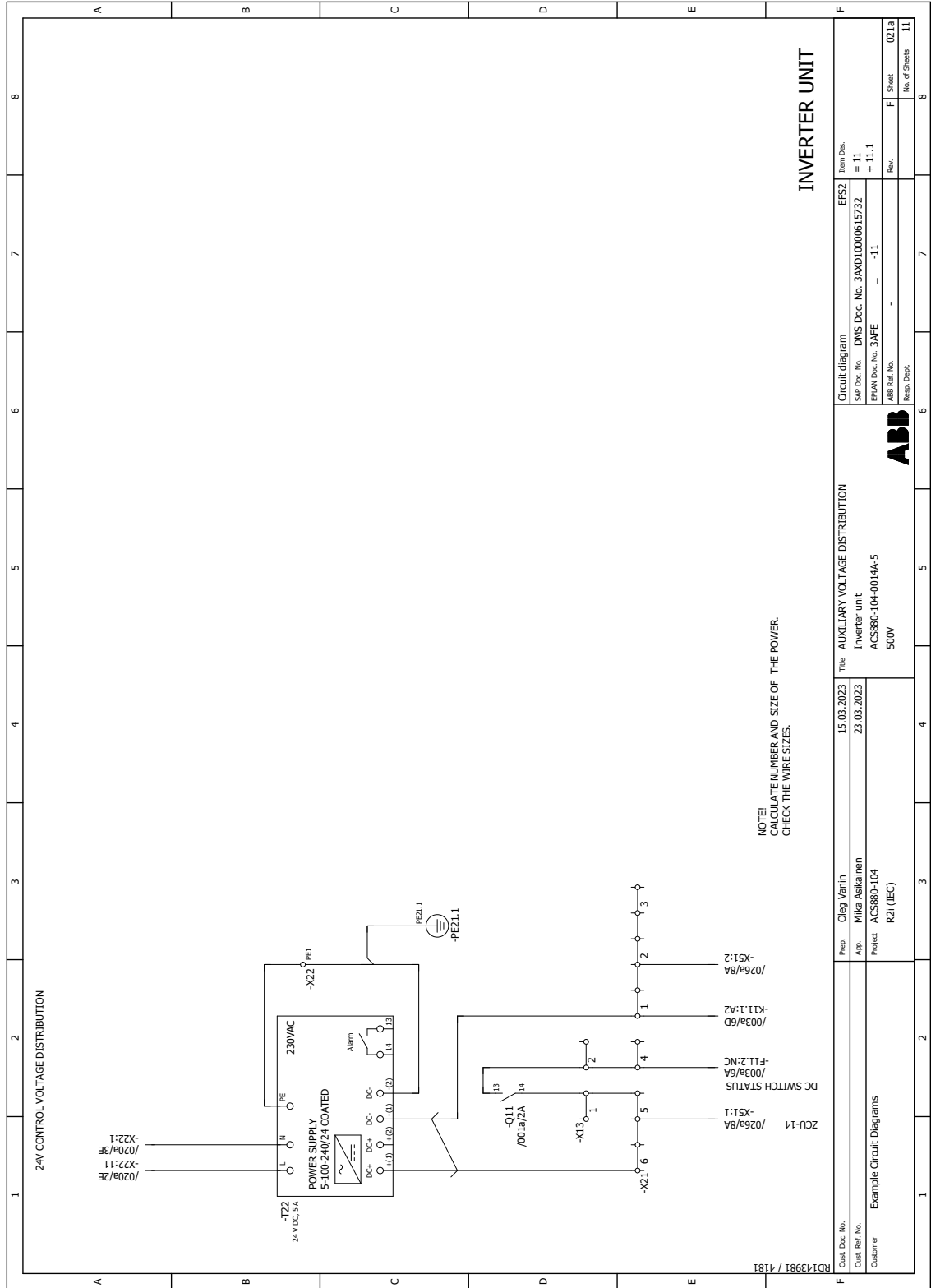

■ Frames R1i...R4i – Sheet 040a

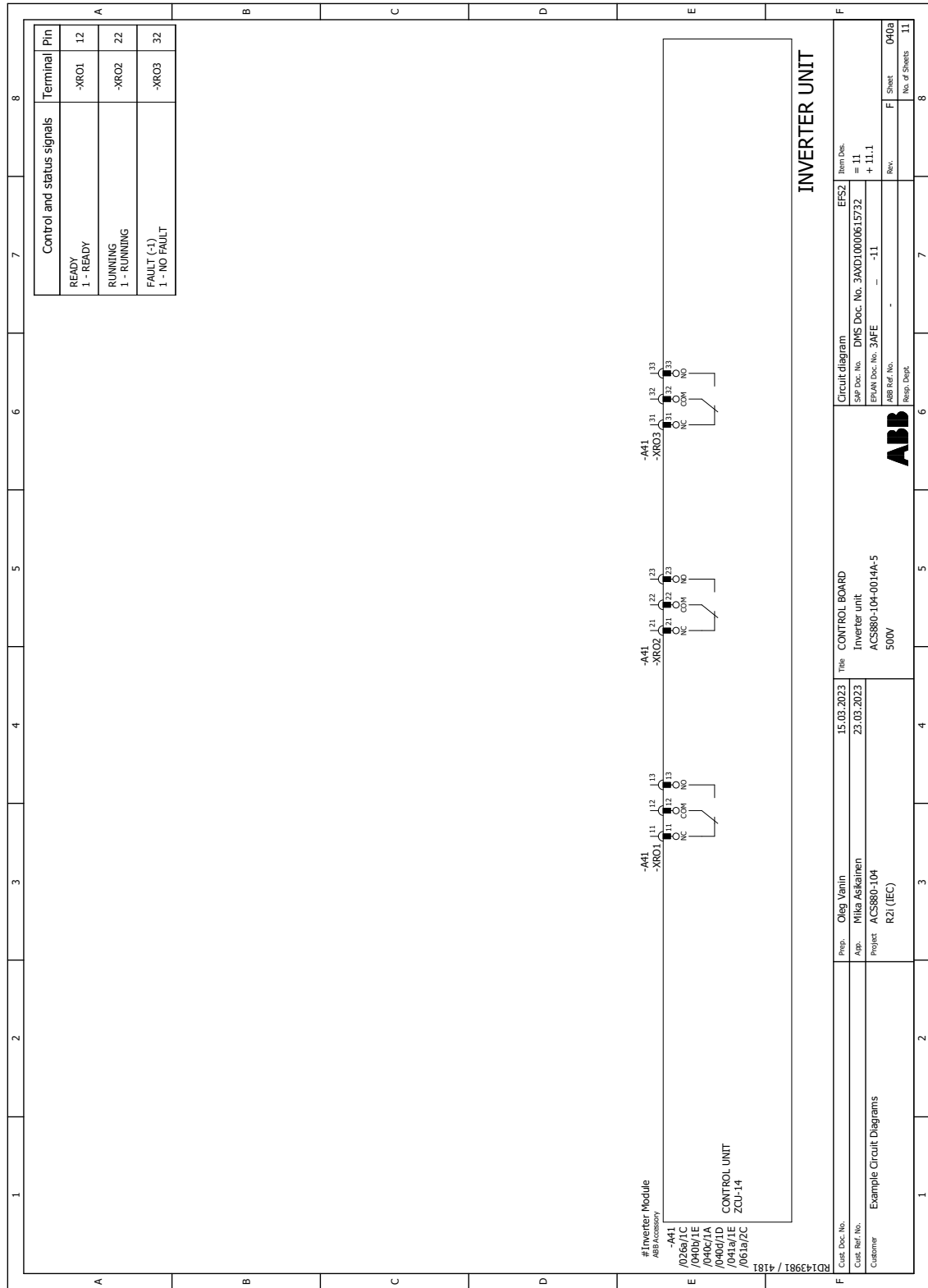

■ Frames R1i...R4i – Sheet 040c

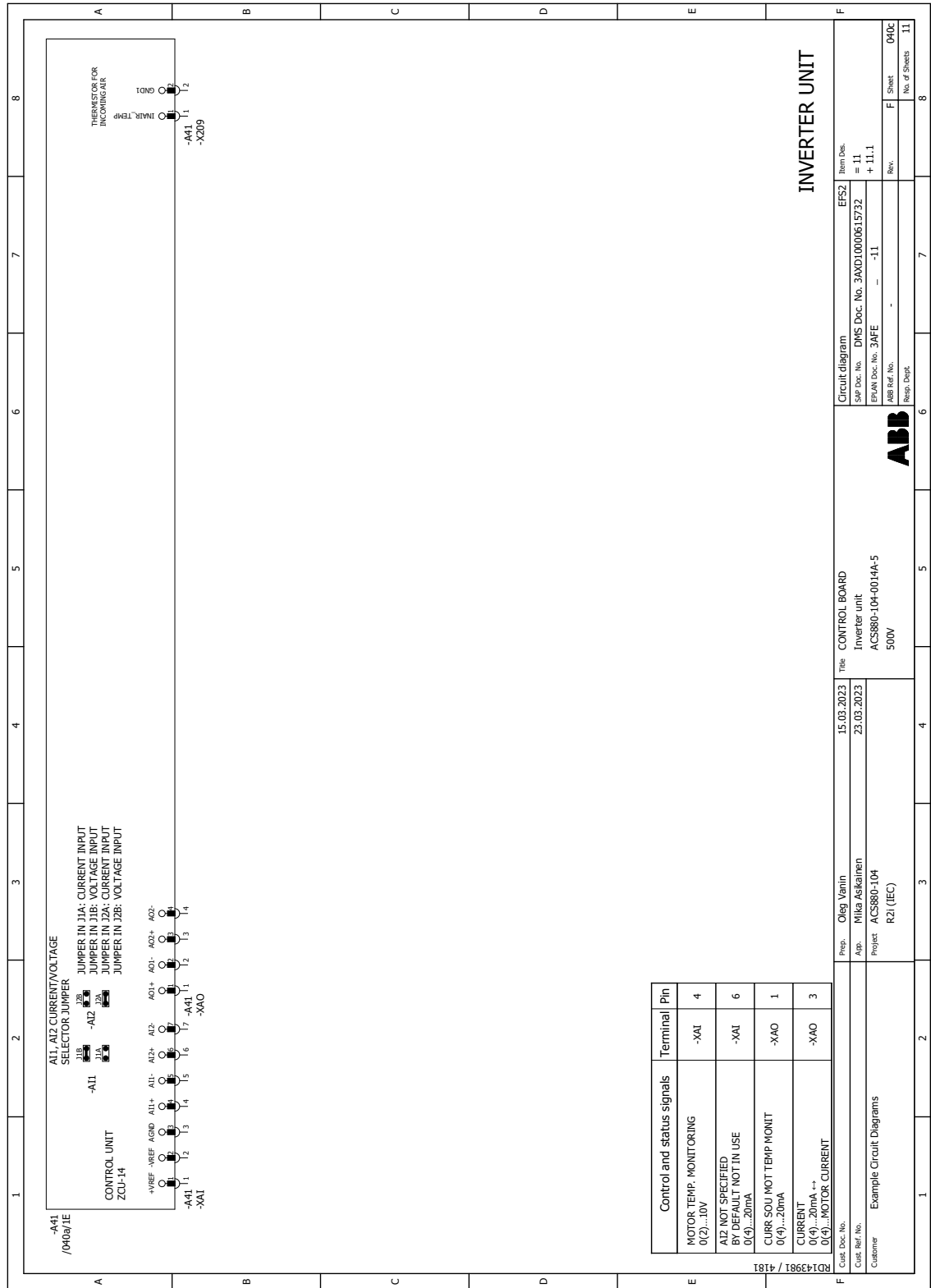

INVERTER UNIT

RD143981 / 4181

Customer: Example Circuit Diagrams

Cost. Ref. No.:

Prep. Oleg Vainin
App. Mika Asikainen
Project ACS880-104

Title: CONTROL BOARD
Inverter unit
ACS880-104-0014A-5
500V

ABB

Resp. Dept.

Item Des. EFSZ
SAP Doc. No. DMS Doc. No. 3AXD10000615732 = 11
EPAN Doc. No. 3AFE - - -11
ABB Ref. No. - - -

Rev. = 11.1
F Sheet 040c
No. of Sheets 11

■ Frames R1i...R4i – Sheet 040d

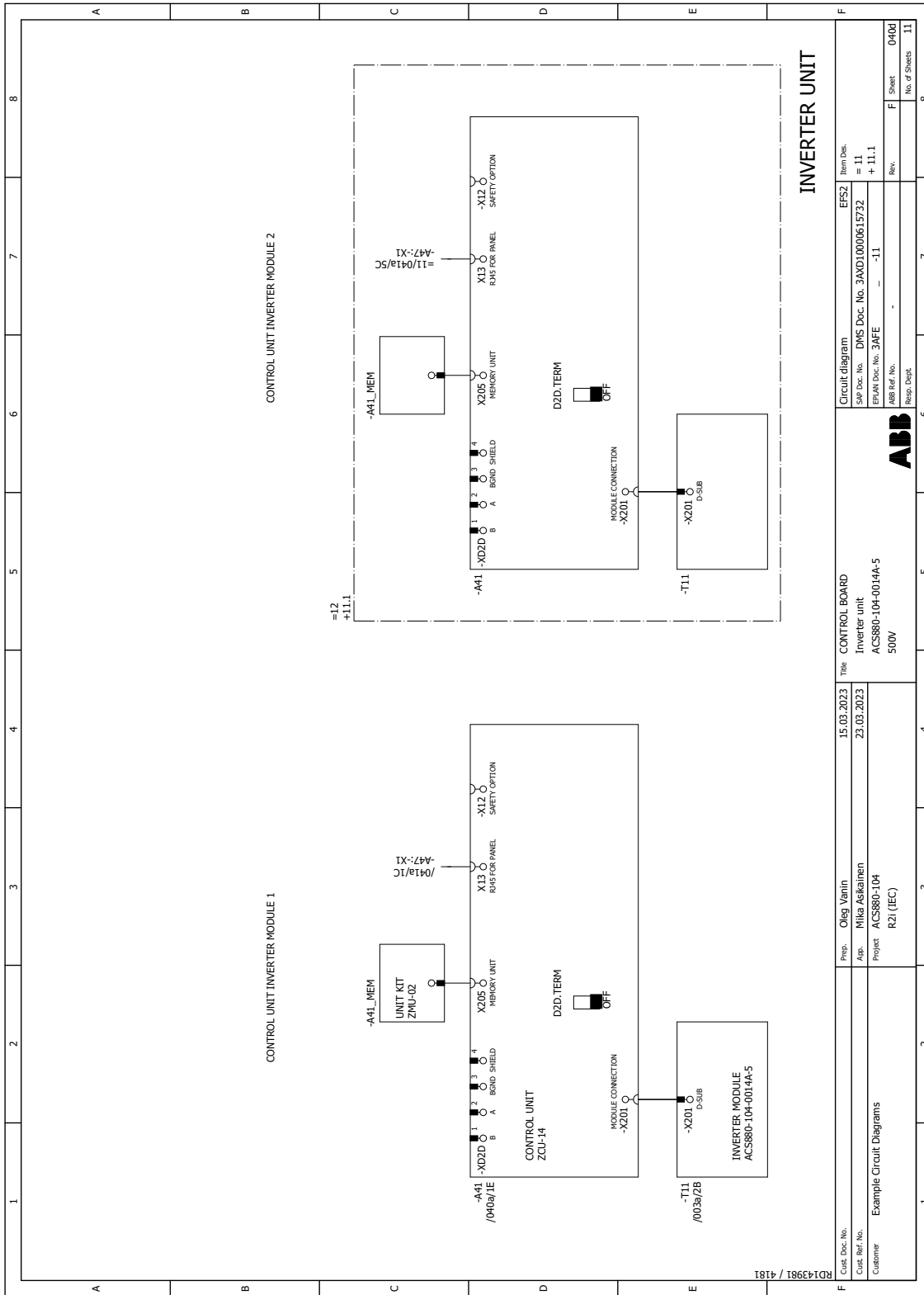

RD143981 / 4181

Cust. Doc. No.		RD143981 / 4181	
Customer		Example Circuit Diagrams	
Prep.	Oleg Vapin	Date	15.03.2023
App.	Mika Askariinen	Date	23.03.2023
Project	ACS880-104 R21 (IEC)	Title	CONTROL BOARD Inverter unit ACS880-104-0014A-5 500V
Circuit diagram		Item Desc.	EF52
SAP Doc. No.	DMS Doc. No. 3AXD10000615752	= 11 + 11.1	
EPAN Doc. No. 3AFE	-11	Rev.	F
ABB Ref. No.	-	Sheet	040d
Resp. Dept.	-	No. of Sheets	11

■ Frames R1i...R4i – Sheet 041a

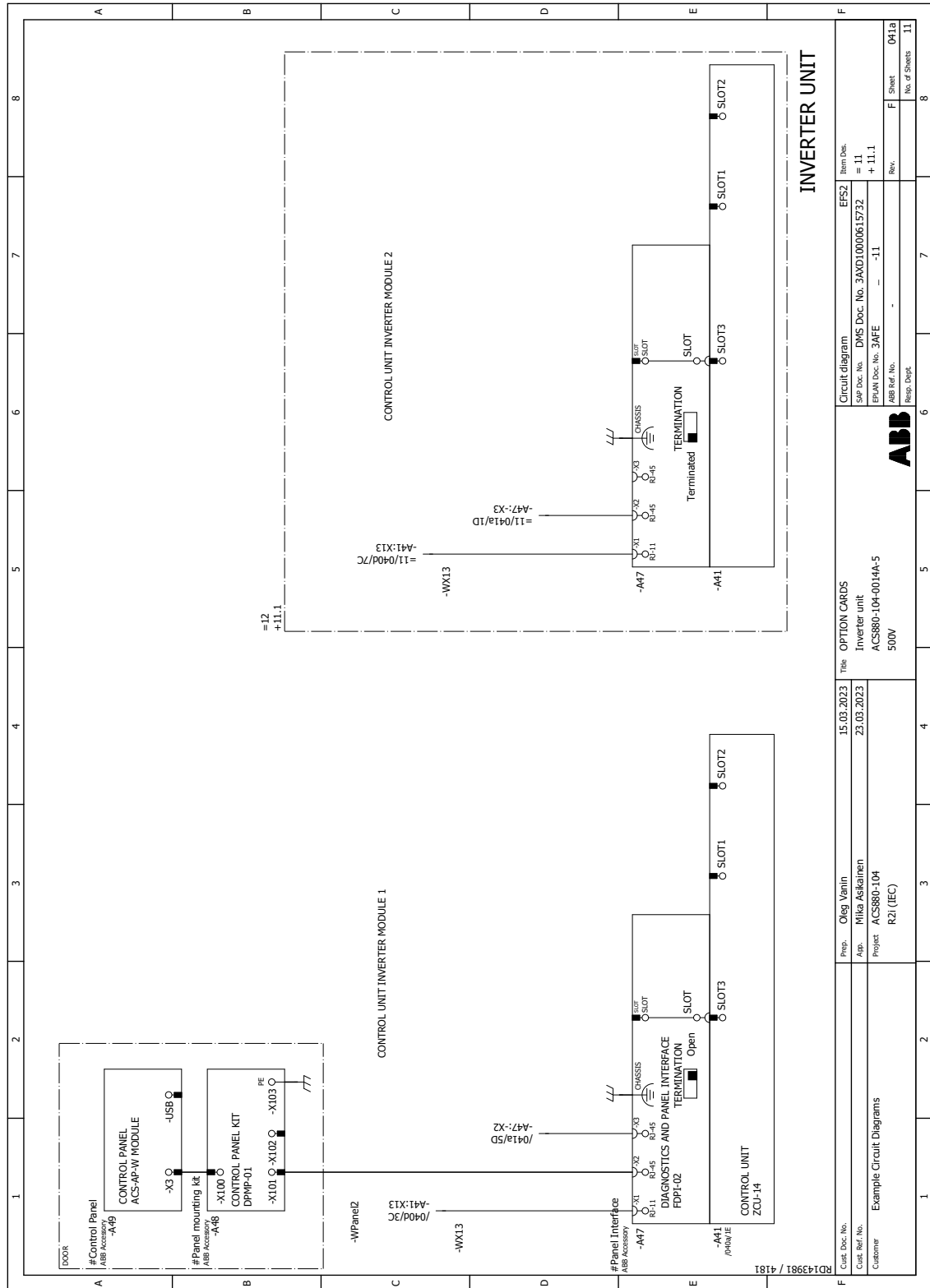

■ Frames R1i...R4i – Sheet 061a

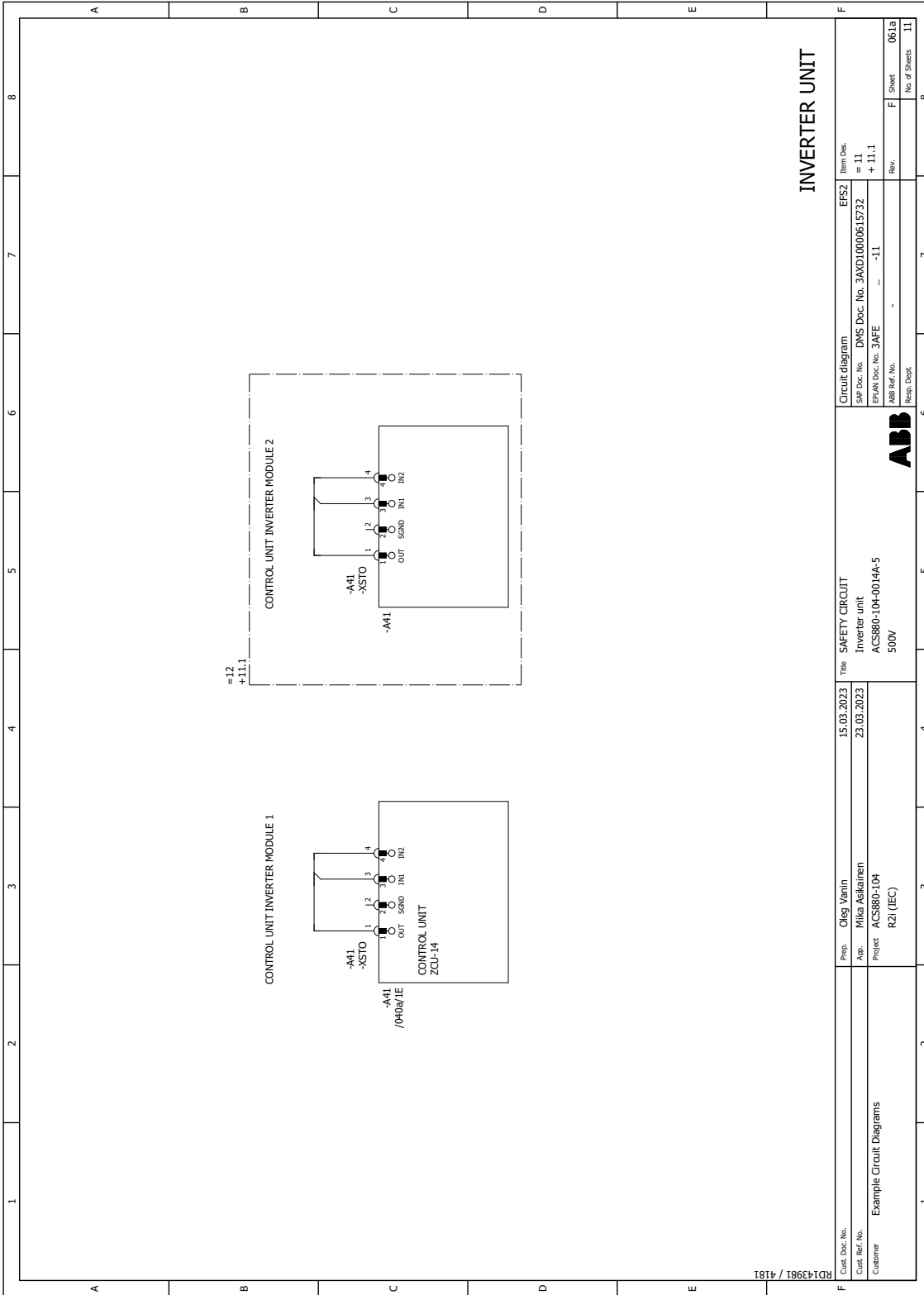

INVERTER UNIT

RD143981 / 4181		15.03.2023		11		EFS2	
Prep:	Oleg Vanin	23.03.2023		+ 11.1		Item Des.	
App:	Mika Askariinen			-11		= 11	
Project:	ACS880-104					+ 11.1	
Customer:	R21 (IEC)					Rev.	
Example Circuit Diagrams						F Sheet	
						061a	
						11	
						No. of Sheets	
						8	



SAFETY CIRCUIT
 Inverter unit
 ACS880-104-0014A-5
 500V

Circuit diagram
 Item Des.
 EFS2
 DMS Doc. No. 3AXD10000615732
 + 11.1
 -11

Rev. 061a
 No. of Sheets 11

Frame R5i

■ Frame R5i – Sheet 000A

A		B		C		D		E		F			
1	2	3	4	5	6	7	8	<div style="text-align: center;">  <p>Example Circuit Diagrams</p> <p>Project type ACS880-104 Inverter Unit</p> <p>Converter type R5i</p> <p>Frame Size ACS880-104-0052A-7</p> <p>Type Code Revision C</p> </div>					
Customer Example Circuit Diagrams		Prep. Oleg Vainn		Date 15.03.2023		Title Title page / cover sheet						Item Desc.	
Cust. Ref. No.		App. Mika Asikainen		Date 21.03.2023		SAP Doc. No. DIMS doc. nr. 3AXD1000058968						=	
Customer ACS880-104		Project ACS880-104				EPLAN Doc. No. 3AFE						+	
R5i						ABB Ref. No.						Rev.	
1	2	3	4	5	6	7	8	C		Sheet 000A			
										No. of Sheets 5			

■ Frame R5i – Sheet 000B

1		2		3		4		5		6		7		8																																										
Higher-level function		Page	Page description		Revision																																																			
11		000A	Title page / cover sheet		F																																																			
		000C	Structured Identifier overview		F																																																			
		000D	Summarized parts list		F																																																			
		300A	Symbol Overview		F																																																			
		001a	MAIN CIRCUIT		F																																																			
		003a	MAIN CIRCUIT		F																																																			
		020a	AUXILIARY VOLTAGE DISTRIBUTION		F																																																			
		021a	AUXILIARY VOLTAGE DISTRIBUTION		F																																																			
		026a	CABINET FAN CONTROL ZCU		F																																																			
		040a	CONTROL BOARD		F																																																			
		040b	CONTROL BOARD		F																																																			
		040c	CONTROL BOARD		F																																																			
		040d	CONTROL BOARD		F																																																			
		041a	OPTION CARDS		F																																																			
		061a	SAFETY CIRCUIT		F																																																			
		<table border="1" style="width: 100%; border-collapse: collapse;"> <tr> <td style="width: 20%;">ABB</td> <td style="width: 20%; text-align: center;">Table of contents</td> <td style="width: 20%;">15.03.2023</td> <td style="width: 20%;">23.03.2023</td> <td style="width: 20%;">15.03.2023</td> <td style="width: 20%;">23.03.2023</td> </tr> <tr> <td>Prep: Oleg Vanin</td> <td>App: Mika Askainen</td> <td colspan="4">Item Des. = +</td> </tr> <tr> <td>Project: ACS880-104 R21 (IEC)</td> <td>Rev.:</td> <td colspan="4">SAP Doc. No. DMS Doc. No. 3AXD10000615732</td> </tr> <tr> <td>Customer: Example Circuit Diagrams</td> <td>Resp. Dept.:</td> <td colspan="4">EPAN Doc. No. 3AFE</td> </tr> <tr> <td></td> <td></td> <td colspan="4">ABB Ref. No. 000B</td> </tr> <tr> <td></td> <td></td> <td colspan="4">Rev.:</td> </tr> <tr> <td></td> <td></td> <td colspan="4">No. of Sheets 5</td> </tr> </table>													ABB	Table of contents	15.03.2023	23.03.2023	15.03.2023	23.03.2023	Prep: Oleg Vanin	App: Mika Askainen	Item Des. = +				Project: ACS880-104 R21 (IEC)	Rev.:	SAP Doc. No. DMS Doc. No. 3AXD10000615732				Customer: Example Circuit Diagrams	Resp. Dept.:	EPAN Doc. No. 3AFE						ABB Ref. No. 000B						Rev.:						No. of Sheets 5			
ABB	Table of contents	15.03.2023	23.03.2023	15.03.2023	23.03.2023																																																			
Prep: Oleg Vanin	App: Mika Askainen	Item Des. = +																																																						
Project: ACS880-104 R21 (IEC)	Rev.:	SAP Doc. No. DMS Doc. No. 3AXD10000615732																																																						
Customer: Example Circuit Diagrams	Resp. Dept.:	EPAN Doc. No. 3AFE																																																						
		ABB Ref. No. 000B																																																						
		Rev.:																																																						
		No. of Sheets 5																																																						

RD143981 / 4181

■ Frame R5i – Sheet 300A

	1	2	3	4	5	6	7	8
A	GENERAL/RELAY COIL, WITH PROTECTIVE CIRCUIT DIODE AND R-HLED		NO SWITCH, OPERATED BY TURNING, 2 POSITIONS		PROTECTIVE EARTH CONNECTED TO FRAME		TERMINAL, FOUR POLE	
B	GENERAL/RELAY COIL		LIMIT SWITCH NC CONTACT MECHANICALLY OPERATED		PROTECTIVE EARTH CONNECTED TO TERMINAL / PE BUSBAR		PLUG AND SOCKET TERMINAL BLOCK WITH 4 CONNECTION POINTS	
C	COIL WITH PICK-UP DELAY		NC SWITCH, TEMPERATURE OPERATED		FUNCTIONAL EARTHING CONNECTED TO TERMINAL		FEMALE AND MALE PLUG	
D	COIL WITH OFF-DELAY		EMERGENCY STOP PUSH BUTTON		FUNCTIONAL BONDING TO FRAME		AMPERE METER	
E	NO CONTACT		DISCONNECT SWITCH, THREE-POLE		LIGHT		CURRENT TRANSFORMER	
F	NC CONTACT		SWITCH DISCONNECTOR WITH FUSES, THREE-POLE		INDUCTOR		VOLTAGE METER	
G	CHANGE OVER CONTACT		FUSE		CAPACITOR		WIRE TERMINATION, INSULATED	
H	NO CONTACT, WITH CLOSING DELAY		FUSE DISCONNECTOR		RESISTOR		SHIELDED CABLE	
I	TWO NO CONTACTS ONE INPUT, TWO OUTPUTS		CIRCUIT BREAKER		POWER RESISTOR WITH FUSE			
J	TWO CONNECTED CHANGE OVER CONTACTS		MOTOR OVERLOAD SWITCH WITH SWITCH MECHANISM		PHASE SELECTING SWITCH			
K	POWER NO CONTACT OF A CONTACTOR		COMMON MODE FILTER FOR HIGH-FREQUENCY CURRENTS		TRANSFORMER		THERMAL OPERATION	
L	PUSH BUTTON WITH NO CONTACT				EMC FILTER		DISCONNECT	
M	PUSH BUTTON WITH NC CONTACT						DISCONNECT, CAN BE OPERATED WHILE NOMINAL CURRENT IS APPLIED	
N							BREAKER, SHORT-CIRCUIT BREAKING CAPABILITY	
O								
P								
Q								
R								
S								
T								
U								
V								
W								
X								
Y								
Z								
AA								
AB								
AC								
AD								
AE								
AF								
AG								
AH								
AI								
AJ								
AK								
AL								
AM								
AN								
AO								
AP								
AQ								
AR								
AS								
AT								
AU								
AV								
AW								
AX								

■ Frame R5i – Sheet 001a

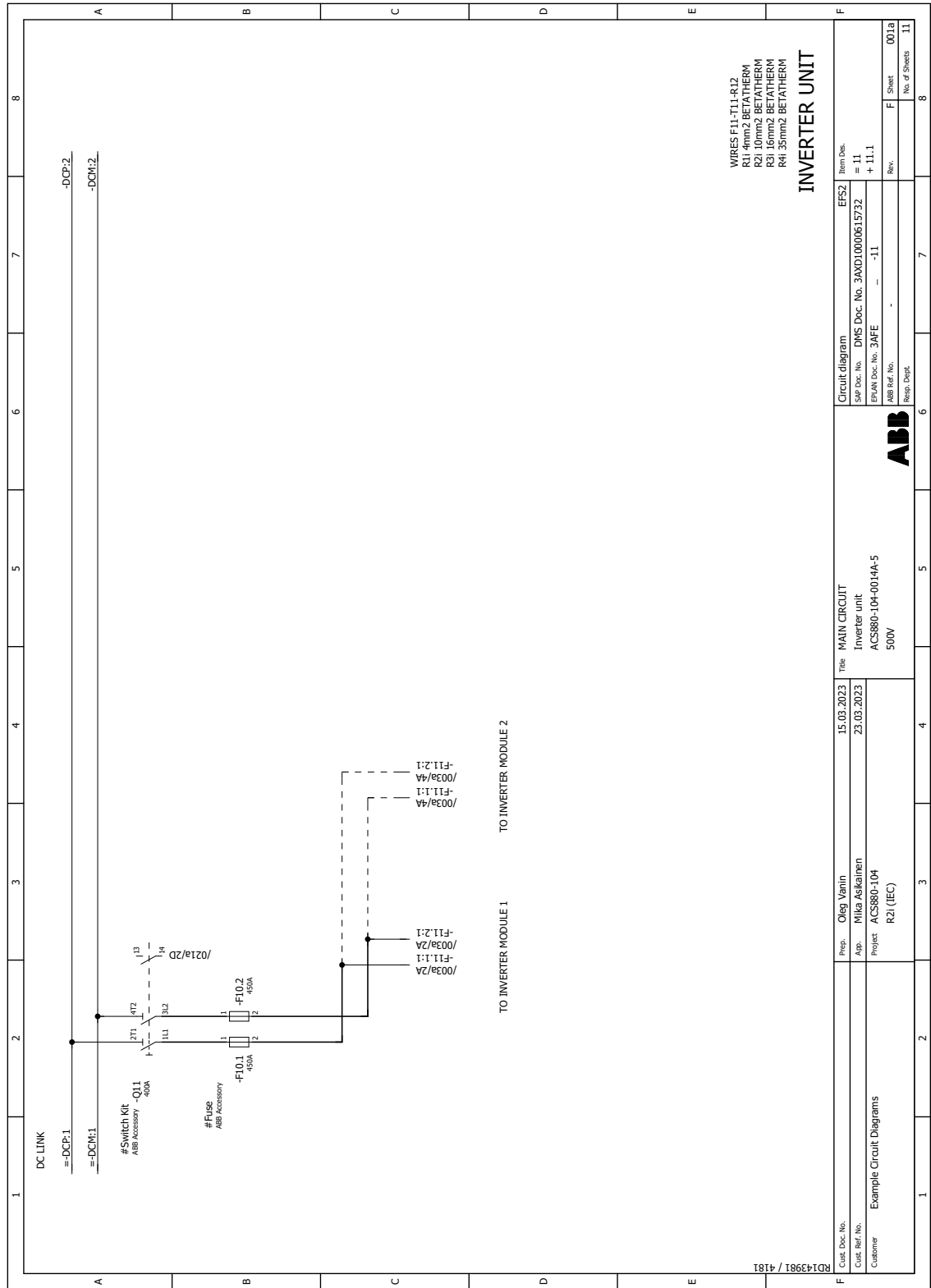

WIRES F11:T11,R12
R11: 16mm² BETATHERM
R2: 10mm² BETATHERM
R3: 16mm² BETATHERM
R4: 35mm² BETATHERM

INVERTER UNIT

RD143981 / 4181	Customer		Example Circuit Diagrams		Prep. Oleg Vanin		Title MAIN CIRCUIT		Circuit diagram		Item Des.	
	Customer		Example Circuit Diagrams		App. Mika Asikainen		Inverter unit		SAF Doc. No. DMS Doc. No. 3AXD10000615732		= 11	
	Customer		Example Circuit Diagrams		Project ACS880-104		ACS880-104-0014A-5		EPAN Doc. No. 3AFE		+ 11.1	
	Customer		Example Circuit Diagrams		R21 (IEC)		500V		ABB Ref. No.		Rev.	
	Customer		Example Circuit Diagrams		R21 (IEC)		500V		Resp. Dept.		F Sheet	
	Customer		Example Circuit Diagrams		R21 (IEC)		500V		Resp. Dept.		No. of Sheets	
	Customer		Example Circuit Diagrams		R21 (IEC)		500V		Resp. Dept.		11	



■ Frame R5i – Sheet 003a

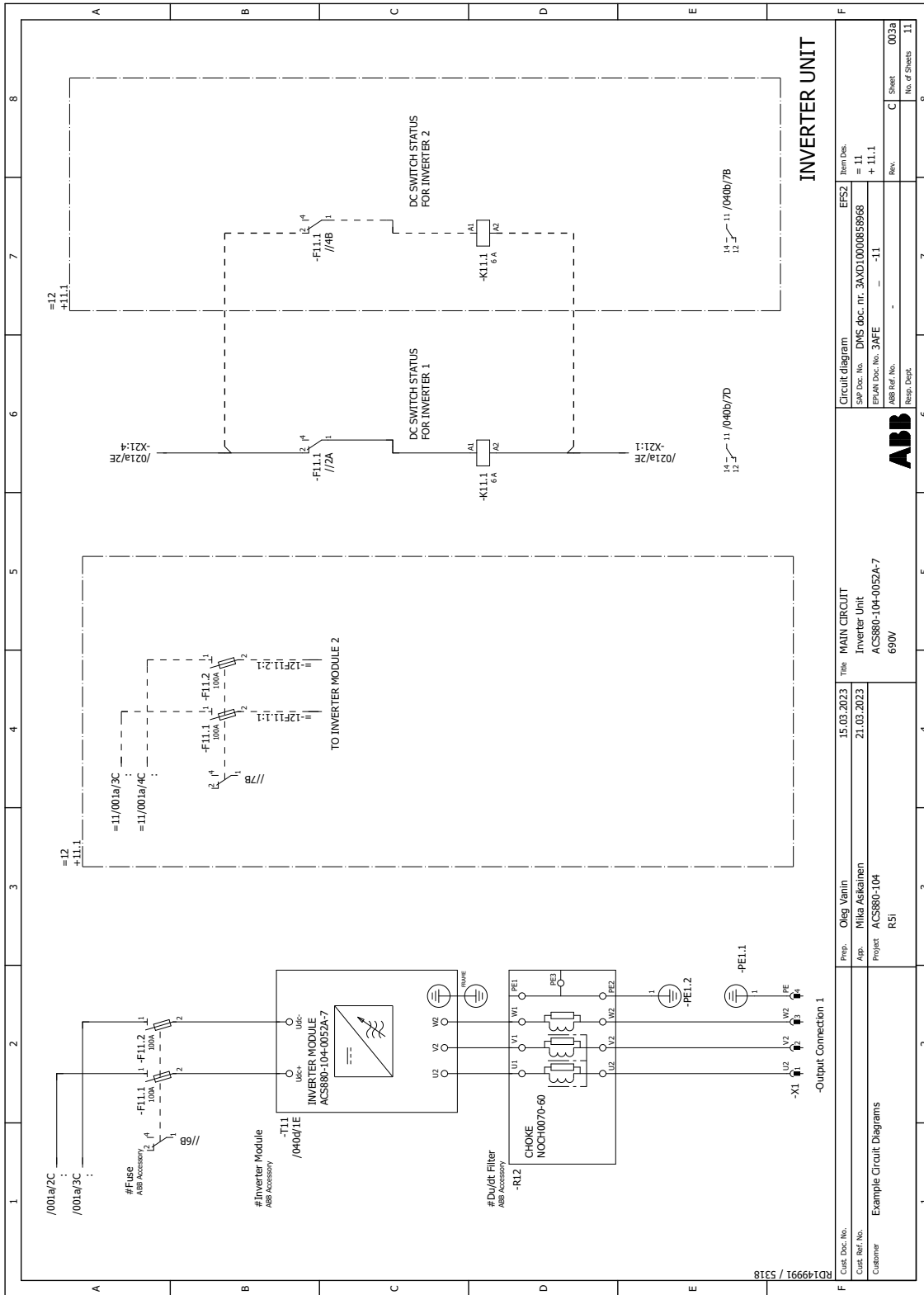

RD149991 / 5318

Customer	Example Circuit Diagrams
Customer Ref. No.	
Prep.	Oleg Vanin
App.	Mika Askariin
Project	ACS880-104 R5i
Date	15.03.2023 21.03.2023
Title	MAIN CIRCUIT Inverter Unit ACS880-104-0052A-7 690V
Circuit diagram	FFS2
SAP Doc. No.	DMS doc. nr. 3AND1000085996
EPAN Doc. No.	-3AFE
ABB Ref. No.	-
Resp. Dept.	
Item Des.	= 11 + 11.1
Rev.	C
Sheet	003a
No. of Sheets	11

■ Frame R5i – Sheet 026a

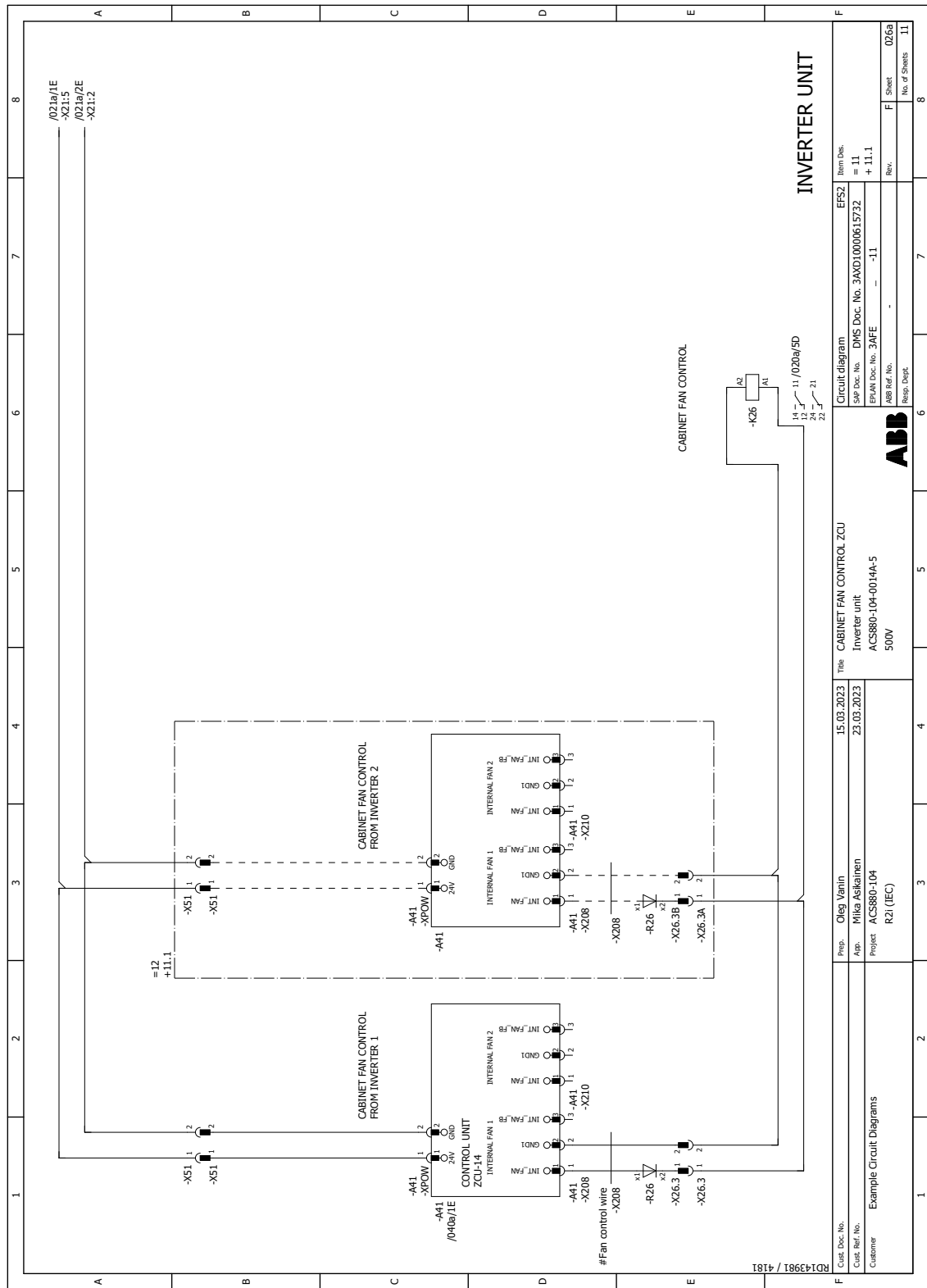

INVERTER UNIT

Cust. Doc. No. RD143981 / 4181		Prep. Oleg Vanin		15.03.2023		Title CABINET FAN CONTROL ZCU		Item Des. EFSZ	
Cust. Ref. No.		App. Mika Asikainen		23.03.2023		Inverter unit		SAP Doc. No. DMS Doc. No. 3AXD10000615732 = 11	
Customer		Project ACS880-104		R21 (IEC)		ACS880-104-0014A-5 500V		EPAN Doc. No. 3AFE - - - - -11	
								ABB Ref. No. Resp. Dept.	
								F Sheet No. of Sheets	
								026a 11	

■ Frame R5i – Sheet 040a

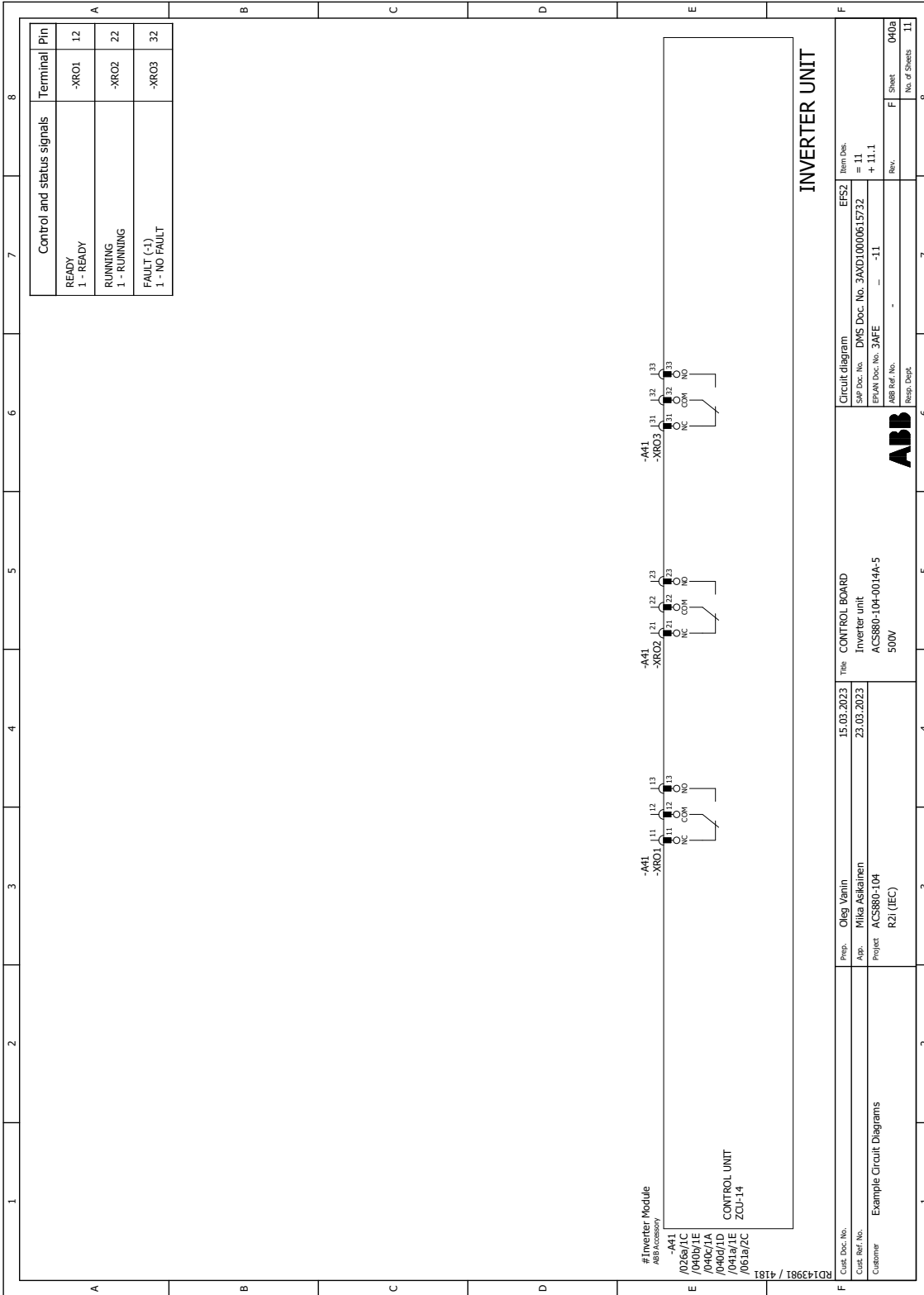

■ Frame R5i – Sheet 040b

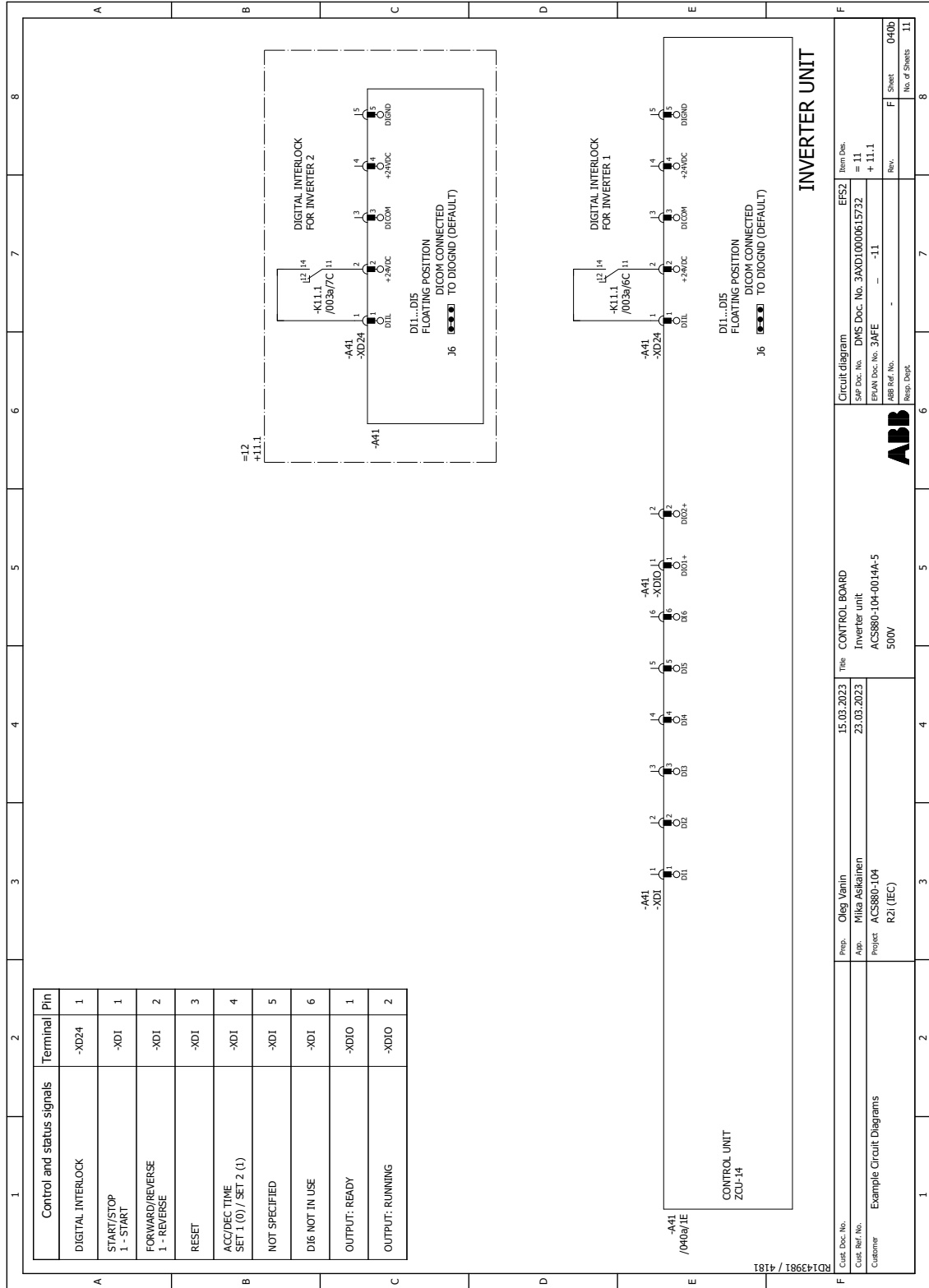

■ Frame R5i – Sheet 040c

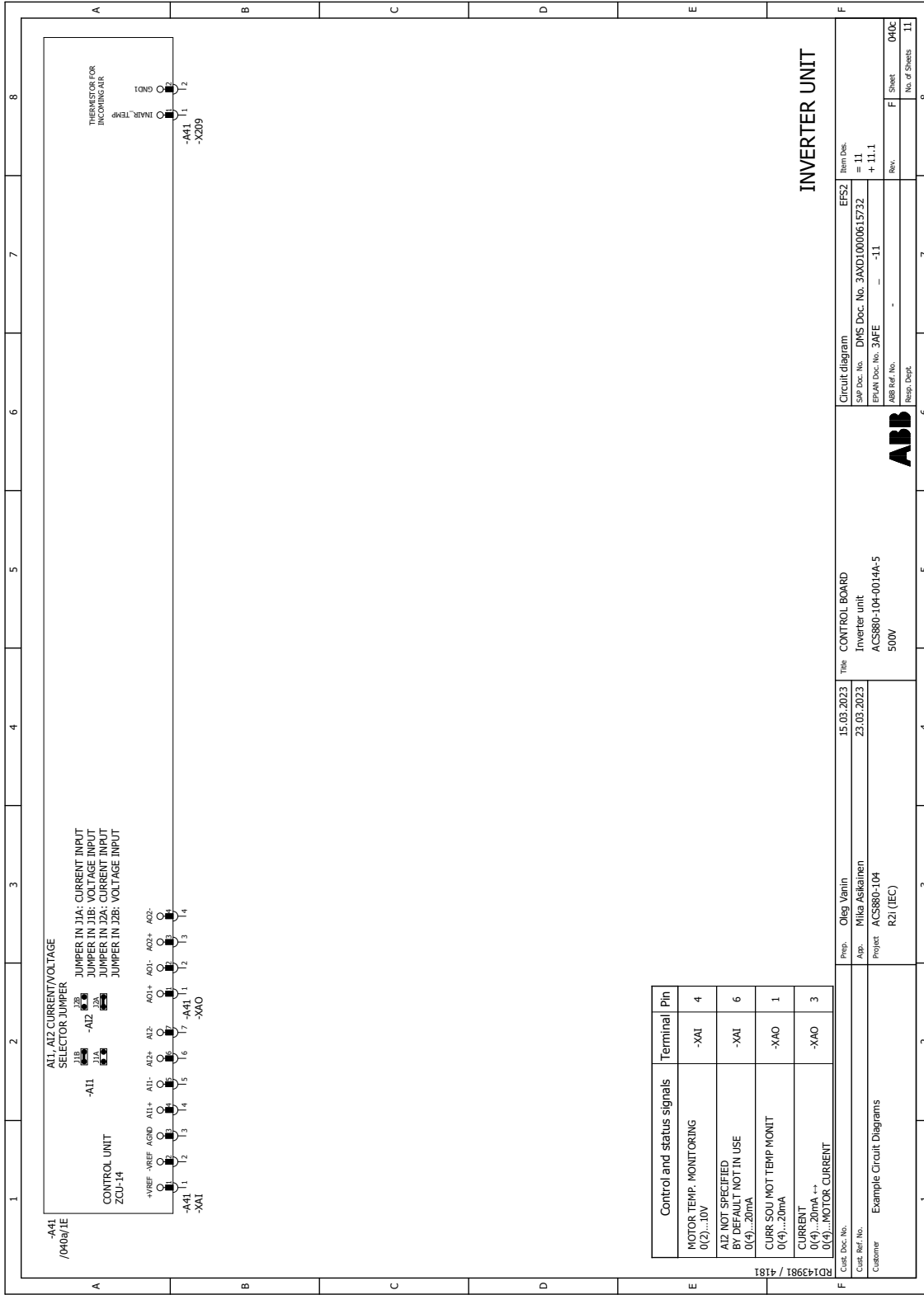

■ Frame R5i – Sheet 040d

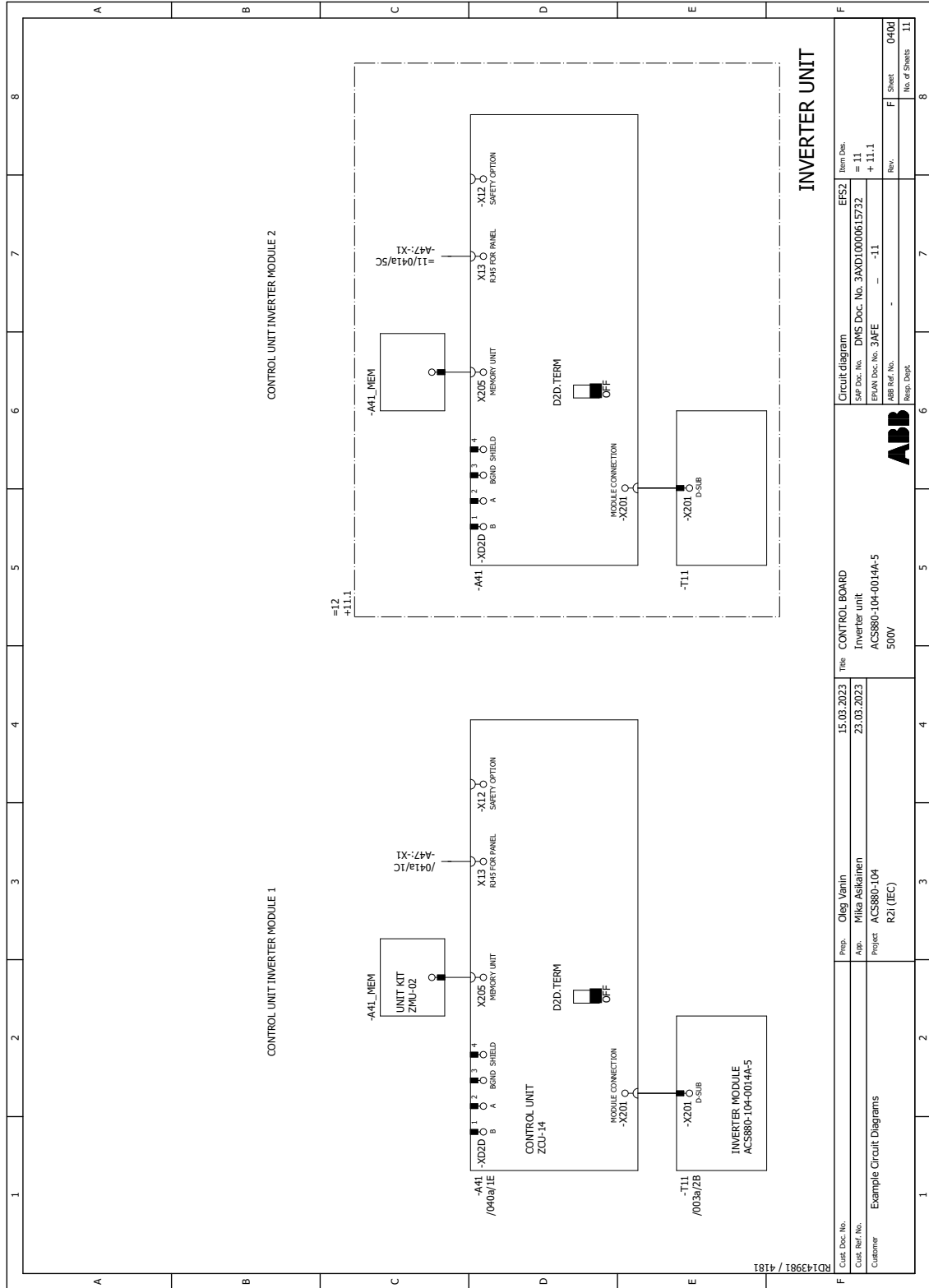

RD143981 / 4181		Title		Item Des.	
Customer		CONTROL BOARD		EFSZ	
Example Circuit Diagrams		Inverter unit		= 11	
		ACS880-104-0014A-5		+ 11.1	
		500V			
		Prep. Oleg Vanin		SAF Doc. No. DMS Doc. No. 3AXD10000615732	
		App. Mika Asikainen		EPAN Doc. No. 3AFE	
		Project ACS880-104		ABB Ref. No.	
		R21 (IEC)		Resp. Dept.	
				Rev. -11	
				F Sheet 040d	
				I1	

■ Frame R5i – Sheet 041a

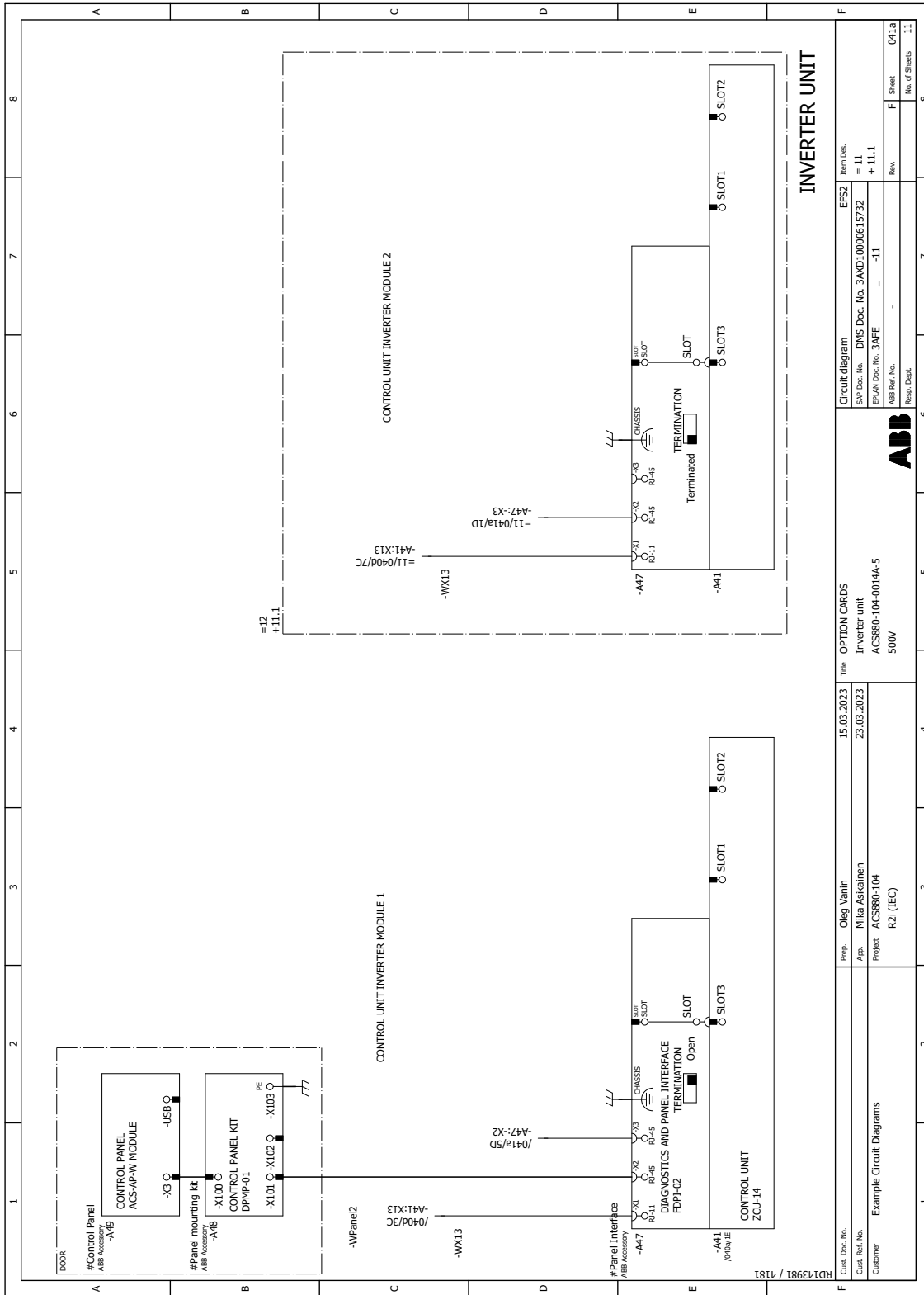

RD143981 / 4181		15.03.2023		15.03.2023		15.03.2023		15.03.2023		15.03.2023	
Customer: Example Circuit Diagrams		Prep: Oleq Vanin		Title: OPTION CARDS		Circuit diagram		Item Des: EFS2		Rev: 11	
Customer: Example Circuit Diagrams		App: Miia Askainen		Inverter unit		SAP Doc. No. 3AXD10000615732		SAP Doc. No. 3AXD10000615732		Rev: 11	
Customer: Example Circuit Diagrams		Project: ACS880-104		ACS880-104-0014A-5		EPAN Doc. No. 3AFE		EPAN Doc. No. 3AFE		Rev: 11	
Customer: Example Circuit Diagrams		R21 (IEC)		500V		ABB Ref. No.		ABB Ref. No.		Rev: 11	
Customer: Example Circuit Diagrams		R21 (IEC)		500V		Resp. Dept.		Resp. Dept.		Rev: 11	
Customer: Example Circuit Diagrams		R21 (IEC)		500V		Resp. Dept.		Resp. Dept.		Rev: 11	
Customer: Example Circuit Diagrams		R21 (IEC)		500V		Resp. Dept.		Resp. Dept.		Rev: 11	

■ Frame R5i – Sheet 061a

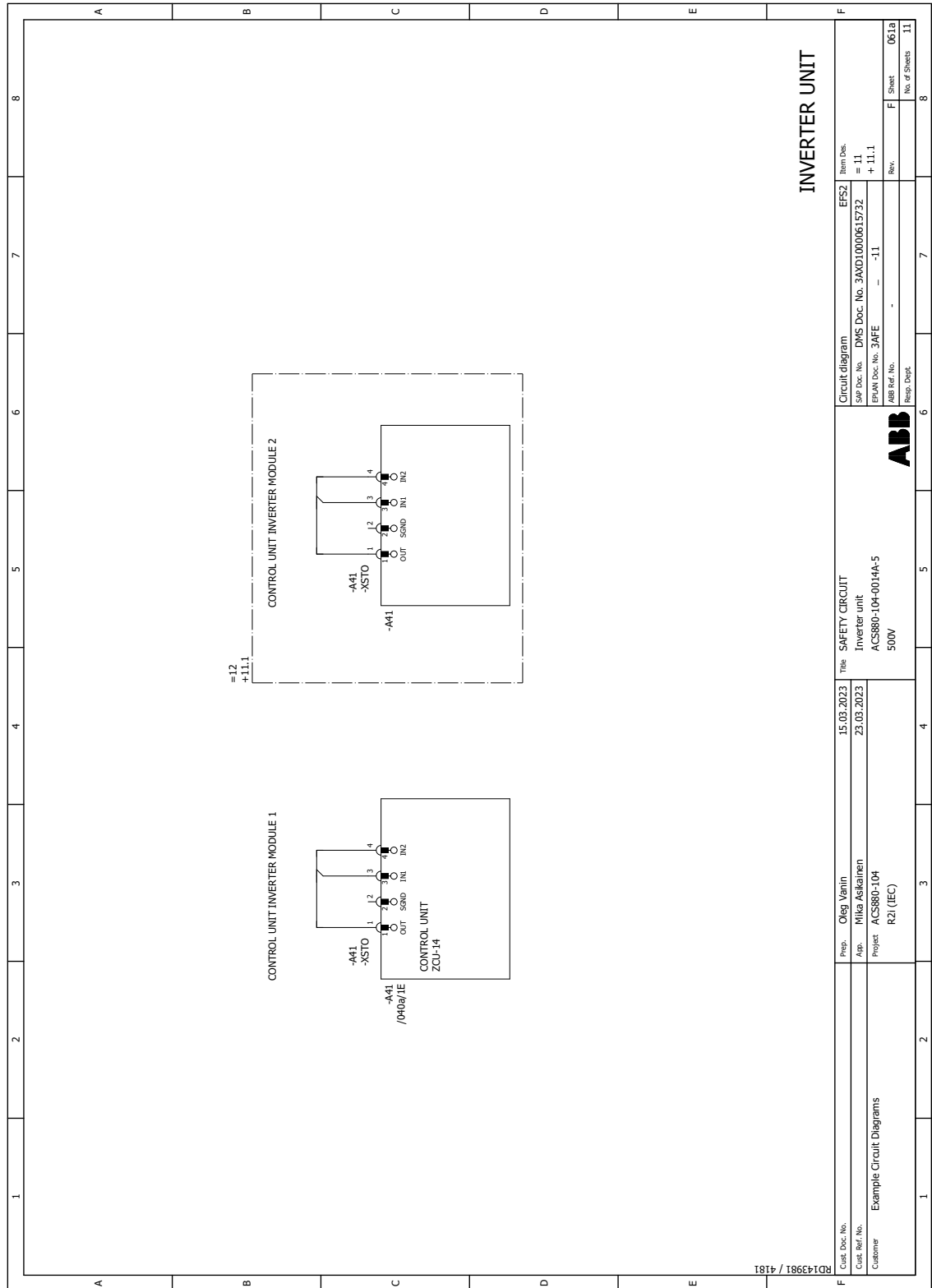

RD143981 / 4181

Frame R6i

■ Frame R6i – Sheet 000A

1	2	3	4	5	6	7	8
A							B
A							B
B	Project type Example Circuit Diagrams						C
C	Converter type ACS880-104 Inverter Unit						D
D	Frame Size R6i						E
E	Type Code ACS880-104-0140A-5+F272+V992						F
F	Revision Revision D						8
Used EPLAN version: 3.19491							
F	2	3	4	5	6	7	8
F	Cust. Doc. No. Example Circuit Diagrams			Title page / cover sheet		Circuit diagram	
F	Prop. OJeb Vainn App. Mika Asikainen			Date 06.09.2023 07.09.2023		Item Desc. F +	
F	Project ACS880-104 R6i			SAP Doc. No. DMS doc. tit. 3AXD10000615733		EPLAN Doc. No. 3AFE	
F	ABB			ABB Ref. No.		Rev.	
F	Resp. Dept.			ABB Ref. No.		Sheet 000A	
F	No. of Sheets 5			No. of Sheets 5		No. of Sheets 5	

■ Frame R6i – Sheet 000B

1	2	3	4	5	6	7	8	
Higher-level function	Page	Page description						Revision
	000A	Title page / cover sheet						D
	000C	Structured identifier overview						D
	000D	Summarized parts list						D
	300A	Symbol Overview						D
	001a	MAIN CIRCUIT						D
	020a	AUXILIARY VOLTAGE DISTRIBUTION						D
	040a	CONTROL BOARD						D
	040b	CONTROL BOARD						D
	040c	CONTROL BOARD						D
041a	OPTION CARDS						D	
								
Cust. Doc. No. Cust. Ref. No. Customer		Prep. Oleg Vanin App. Mika Asikainen Project ACS800-104 R6i		Title Table of contents 06.09.2023 07.09.2023		Circuit diagram EFSZ SAP Doc. No. DMS doc. nr. 3AXD10000615733 EPAN Doc. No. 3AFE ABB Ref. No. Resp. Dept.		
Example Circuit Diagrams						Item Des. = + Rev. D Sheet 000B No. of Sheets 5		

■ Frame R6i – Sheet 300A

	1	2	3	4	5	6	7	8
A	GENERAL/RELAY COIL WITH PROTECTIVE CIRCUIT DIODE AND R+LED		NO SWITCH, OPERATED BY TURNING, 2 POSITIONS		PROTECTIVE EARTH CONNECTED TO FRAME		TERMINAL FOUR POLE	
B	GENERAL/RELAY COIL		LIMIT SWITCH NC CONTACT MECHANICALLY OPERATED		PROTECTIVE EARTH CONNECTED TO TERMINAL / PE BUSBAR		PLUG AND SOCKET TERMINAL BLOCK WITH 4 CONNECTION POINTS	
C	COIL WITH PICK-UP DELAY		NC SWITCH, TEMPERATURE OPERATED		FUNCTIONAL EARTHING CONNECTED TO TERMINAL		FEMALE AND MALE PLUG	
D	COIL WITH OFF-DELAY		EMERGENCY STOP PUSH BUTTON		FUNCTIONAL BONDING TO FRAME		AMPERE METER	
E	NO CONTACT		DISCONNECT SWITCH, THREE-POLE		LIGHT		CURRENT TRANSFORMER	
F	NC CONTACT		SWITCH DISCONNECTOR WITH FUSES, THREE-POLE		INDUCTOR		VOLTAGE METER	
G	CHANGE OVER CONTACT		FUSE		CAPACITOR		WIRE TERMINATION, INSULATED	
H	NO CONTACT, WITH CLOSING DELAY		FUSE DISCONNECTOR		RESISTOR		SHIELDED CABLE	
I	TWO NO CONTACTS ONE INPUT, TWO OUTPUTS		CIRCUIT BREAKER		POWER RESISTOR WITH FUSE			
J	TWO CONNECTED CHANGE OVER CONTACTS		MOTOR OVERLOAD SWITCH WITH SWITCH MECHANISM		PHASE SELECTING SWITCH			
K	POWER NO CONTACT OF A CONTACTOR		COMMON MODE FILTER FOR HIGH FREQUENCY CURRENTS		TRANSFORMER		PHASE SELECTING SWITCH	
L	PUSH BUTTON WITH NO CONTACT				EMC FILTER		PHASE SELECTING SWITCH	
M	PUSH BUTTON WITH NC CONTACT						PHASE SELECTING SWITCH	
N							PHASE SELECTING SWITCH	
O							PHASE SELECTING SWITCH	
P							PHASE SELECTING SWITCH	
Q							PHASE SELECTING SWITCH	
R							PHASE SELECTING SWITCH	
S							PHASE SELECTING SWITCH	
T							PHASE SELECTING SWITCH	
U							PHASE SELECTING SWITCH	
V							PHASE SELECTING SWITCH	
W							PHASE SELECTING SWITCH	
X							PHASE SELECTING SWITCH	
Y							PHASE SELECTING SWITCH	
Z							PHASE SELECTING SWITCH	
AA							PHASE SELECTING SWITCH	
AB							PHASE SELECTING SWITCH	
AC							PHASE SELECTING SWITCH	
AD							PHASE SELECTING SWITCH	
AE							PHASE SELECTING SWITCH	
AF							PHASE SELECTING SWITCH	
AG							PHASE SELECTING SWITCH	
AH							PHASE SELECTING SWITCH	
AI							PHASE SELECTING SWITCH	
AJ							PHASE SELECTING SWITCH	
AK							PHASE SELECTING SWITCH	
AL							PHASE SELECTING SWITCH	
AM							PHASE SELECTING SWITCH	
AN							PHASE SELECTING SWITCH	
AO							PHASE SELECTING SWITCH	
AP							PHASE SELECTING SWITCH	
AQ							PHASE SELECTING SWITCH	
AR							PHASE SELECTING SWITCH	
AS							PHASE SELECTING SWITCH	
AT							PHASE SELECTING SWITCH	
AU							PHASE SELECTING SWITCH	
AV							PHASE SELECTING SWITCH	
AW							PHASE SELECTING SWITCH	
AX							PHASE SELECTING SWITCH	
AY							PHASE SELECTING SWITCH	
AZ							PHASE SELECTING SWITCH	
BA							PHASE SELECTING SWITCH	
BB							PHASE SELECTING SWITCH	
BC							PHASE SELECTING SWITCH	
BD							PHASE SELECTING SWITCH	
BE							PHASE SELECTING SWITCH	
BF							PHASE SELECTING SWITCH	
BG							PHASE SELECTING SWITCH	
BH							PHASE SELECTING SWITCH	
BI							PHASE SELECTING SWITCH	
BJ							PHASE SELECTING SWITCH	
BK							PHASE SELECTING SWITCH	
BL							PHASE SELECTING SWITCH	
BM							PHASE SELECTING SWITCH	
BN							PHASE SELECTING SWITCH	
BO							PHASE SELECTING SWITCH	
BP							PHASE SELECTING SWITCH	
BQ							PHASE SELECTING SWITCH	
BR							PHASE SELECTING SWITCH	
BS							PHASE SELECTING SWITCH	
BT							PHASE SELECTING SWITCH	
BU							PHASE SELECTING SWITCH	
BV							PHASE SELECTING SWITCH	
BW							PHASE SELECTING SWITCH	
BX							PHASE SELECTING SWITCH	
BY							PHASE SELECTING SWITCH	
BZ							PHASE SELECTING SWITCH	
CA							PHASE SELECTING SWITCH	
CB							PHASE SELECTING SWITCH	
CC							PHASE SELECTING SWITCH	
CD							PHASE SELECTING SWITCH	
CE							PHASE SELECTING SWITCH	
CF							PHASE SELECTING SWITCH	
CG							PHASE SELECTING SWITCH	
CH							PHASE SELECTING SWITCH	
CI							PHASE SELECTING SWITCH	
CJ							PHASE SELECTING SWITCH	
CK							PHASE SELECTING SWITCH	
CL							PHASE SELECTING SWITCH	
CM							PHASE SELECTING SWITCH	
CN							PHASE SELECTING SWITCH	
CO							PHASE SELECTING SWITCH	
CP							PHASE SELECTING SWITCH	
CQ							PHASE SELECTING SWITCH	
CR							PHASE SELECTING SWITCH	
CS							PHASE SELECTING SWITCH	
CT							PHASE SELECTING SWITCH	
CU							PHASE SELECTING SWITCH	
CV							PHASE SELECTING SWITCH	
CW							PHASE SELECTING SWITCH	
CX							PHASE SELECTING SWITCH	
CY							PHASE SELECTING SWITCH	
CZ							PHASE SELECTING SWITCH	
DA							PHASE SELECTING SWITCH	
DB							PHASE SELECTING SWITCH	
DC							PHASE SELECTING SWITCH	
DD							PHASE SELECTING SWITCH	
DE							PHASE SELECTING SWITCH	
DF							PHASE SELECTING SWITCH	
DG							PHASE SELECTING SWITCH	
DH							PHASE SELECTING SWITCH	
DI							PHASE SELECTING SWITCH	
DJ							PHASE SELECTING SWITCH	
DK							PHASE SELECTING SWITCH	
DL							PHASE SELECTING SWITCH	
DM							PHASE SELECTING SWITCH	
DN							PHASE SELECTING SWITCH	
DO							PHASE SELECTING SWITCH	
DP							PHASE SELECTING SWITCH	
DQ							PHASE SELECTING SWITCH	
DR							PHASE SELECTING SWITCH	
DS							PHASE SELECTING SWITCH	
DT							PHASE SELECTING SWITCH	
DU							PHASE SELECTING SWITCH	
DV							PHASE SELECTING SWITCH	
DW							PHASE SELECTING SWITCH	
DX							PHASE SELECTING SWITCH	
DY							PHASE SELECTING SWITCH	
DZ							PHASE SELECTING SWITCH	
EA							PHASE SELECTING SWITCH	
EB							PHASE SELECTING SWITCH	
EC							PHASE SELECTING SWITCH	
ED							PHASE SELECTING SWITCH	
EE							PHASE SELECTING SWITCH	
EF							PHASE SELECTING SWITCH	
EG							PHASE SELECTING SWITCH	
EH							PHASE SELECTING SWITCH	
EI							PHASE SELECTING SWITCH	
EJ							PHASE SELECTING SWITCH	
EK							PHASE SELECTING SWITCH	
EL							PHASE SELECTING SWITCH	
EM							PHASE SELECTING SWITCH	
EN							PHASE SELECTING SWITCH	
EO							PHASE SELECTING SWITCH	
EP							PHASE SELECTING SWITCH	
EQ							PHASE SELECTING SWITCH	
ER							PHASE SELECTING SWITCH	
ES							PHASE SELECTING SWITCH	
ET							PHASE SELECTING SWITCH	
EU							PHASE SELECTING SWITCH	
EV							PHASE SELECTING SWITCH	
EW							PHASE SELECTING SWITCH	
EX							PHASE SELECTING SWITCH	
EY							PHASE SELECTING SWITCH	
EZ							PHASE SELECTING SWITCH	
FA							PHASE SELECTING SWITCH	
FB							PHASE SELECTING SWITCH	
FC							PHASE SELECTING SWITCH	
FD							PHASE SELECTING SWITCH	
FE							PHASE SELECTING SWITCH	
FF							PHASE SELECTING SWITCH	

■ Frame R6i – Sheet 001a

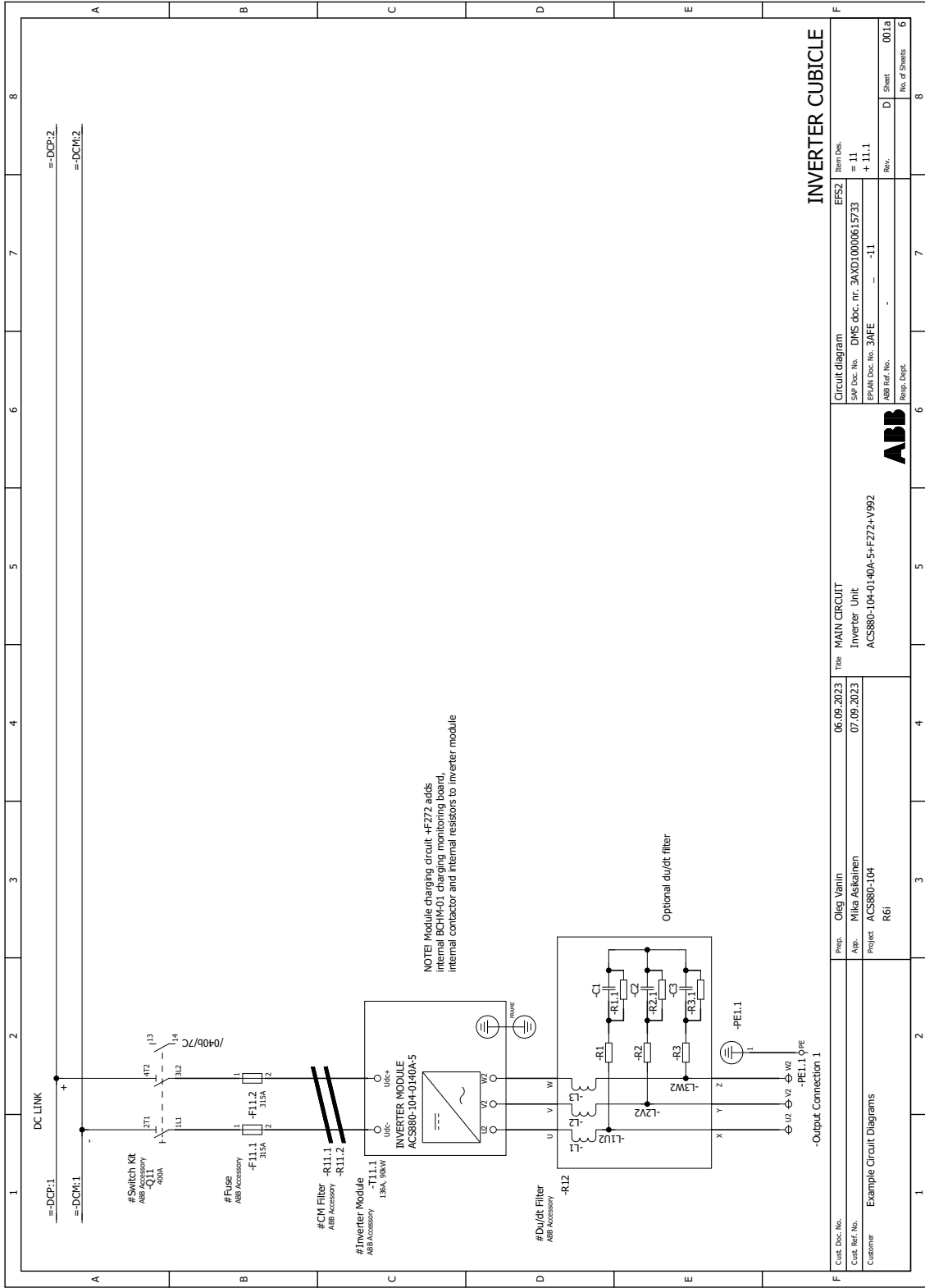

INVERTER CUBICLE

Client Doc. No.	Proj. No.	06.09.2023	Time	07.09.2023	06.09.2023	Item Des.	EF52
Customer	App.	Mika Askariinen	Time	07.09.2023	07.09.2023	Circuit diagram	EF52
Example Circuit Diagrams	Project	ACS880-104 R6i	Time	07.09.2023	07.09.2023	SAP Doc. No.	DMS doc. nr. 3AND10000615733
						EPAN Doc. No.	-11
						ABB Ref. No.	-11
						Resp. Dept.	-
						Rev.	D
						Sheet	001a
						No. of Sheets	6

■ Frame R6i – Sheet 040a

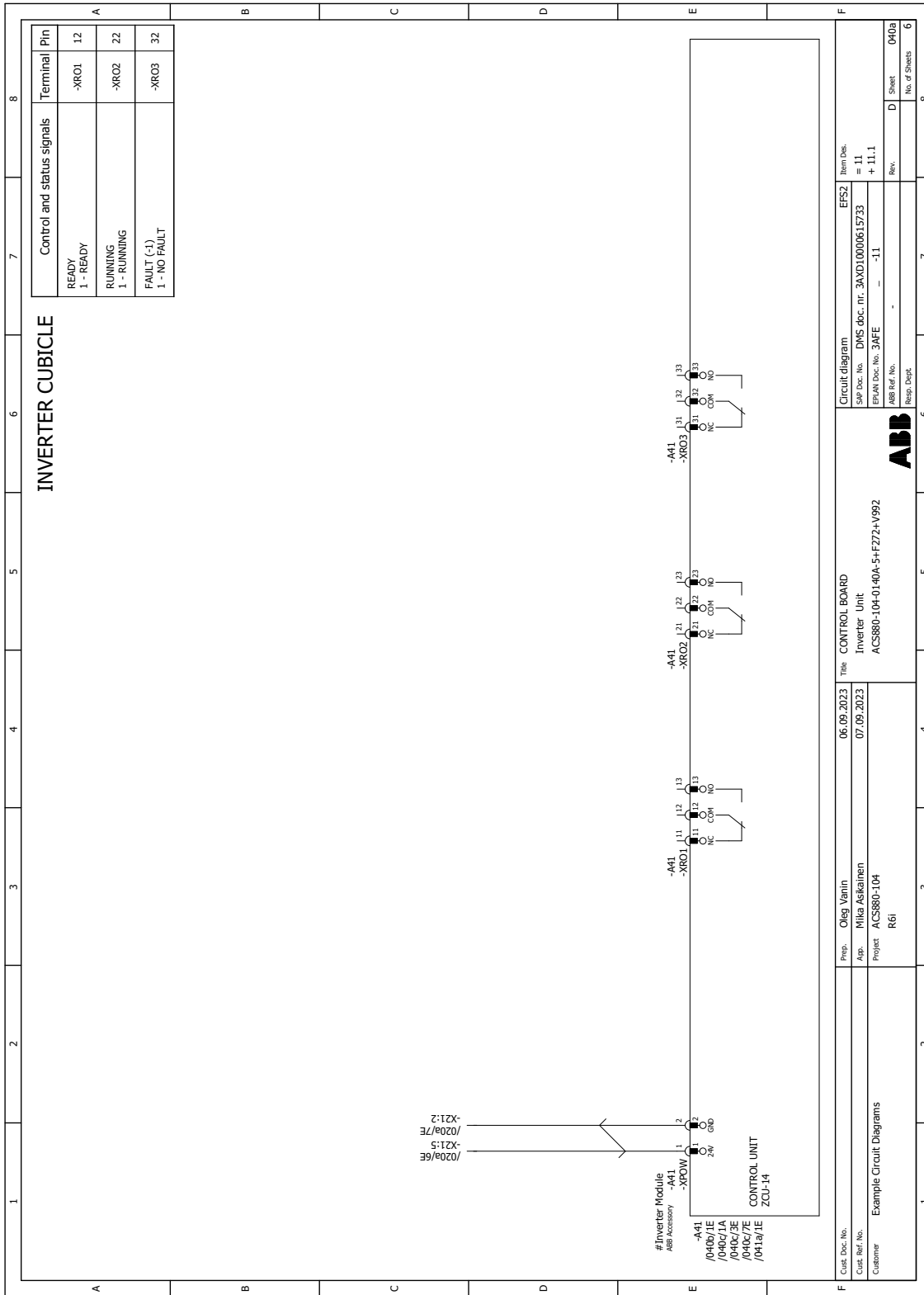

■ Frame R6i – Sheet 040b

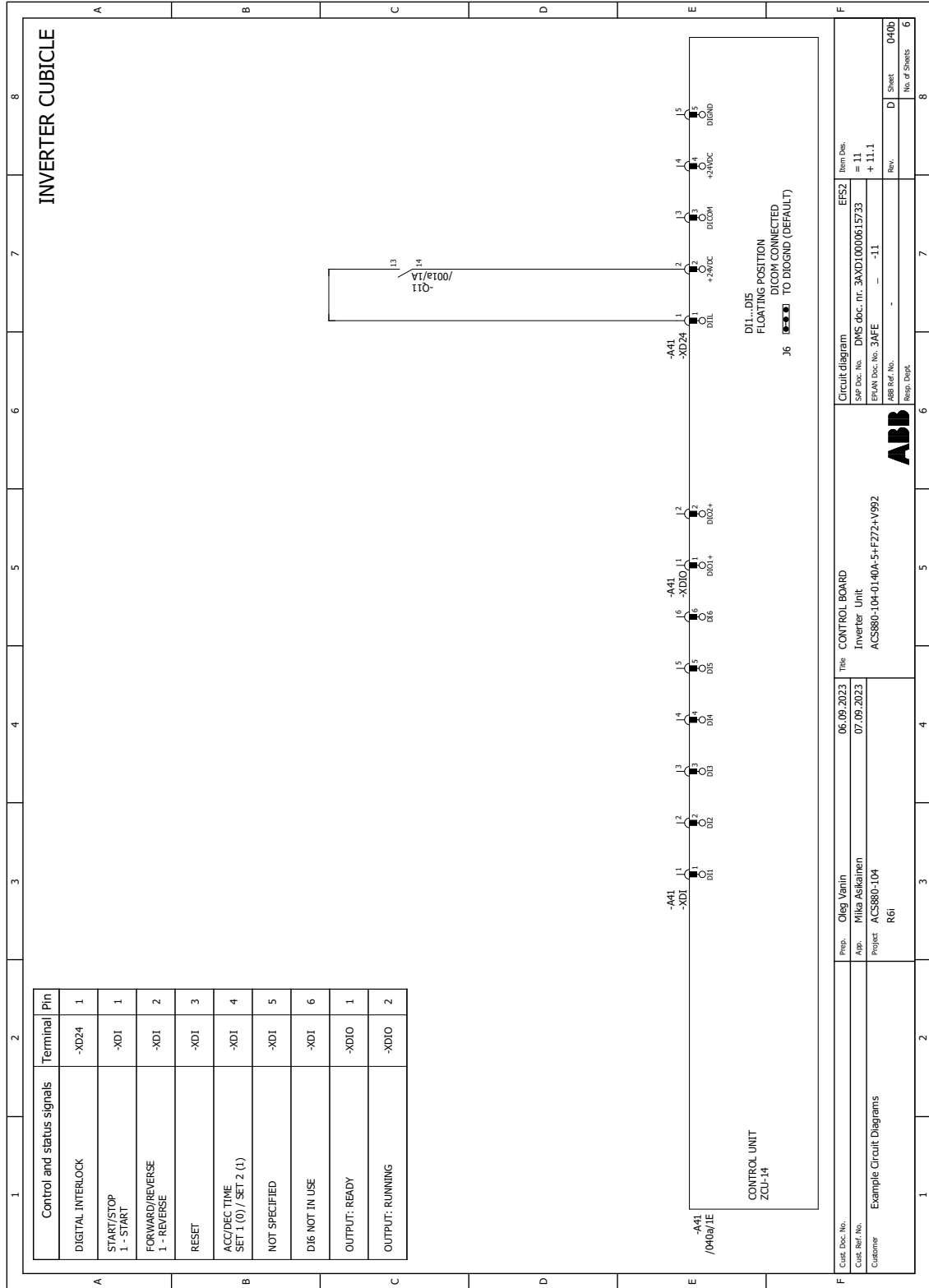

■ Frame R6i – Sheet 040c

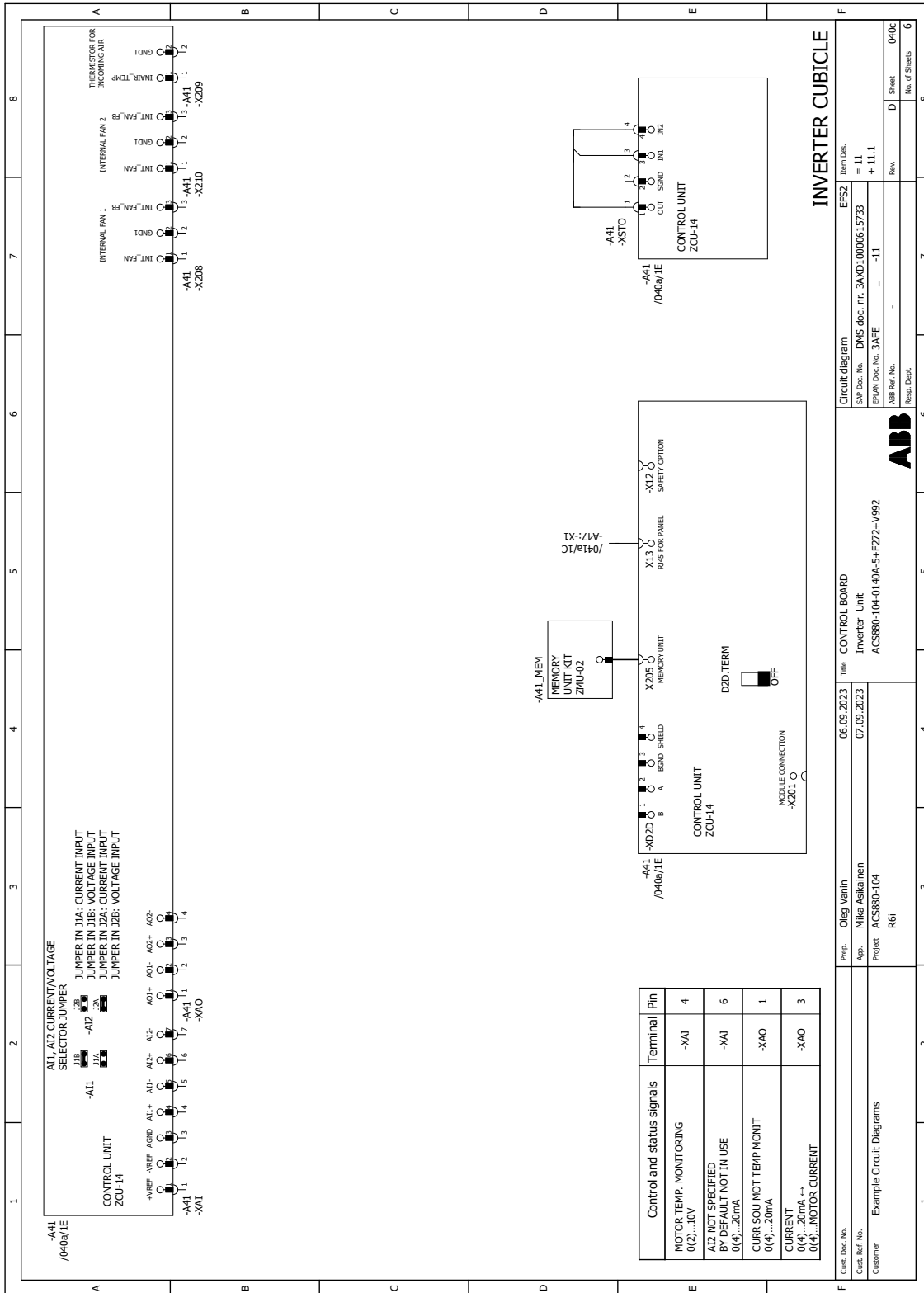

Control and status signals	Terminal	Pin
MOTOR TEMP. MONITORING 0(2)...10V	-XA1	4
AI2 NOT SPECIFIED BY DEFAULT NOT IN USE 0(4)...20mA	-XA1	6
CURR SOU MOTT TEMP MONIT 0(4)...20mA	-XAO	1
CURRENT 0(4)...20mA ↔ 0(4)...MOTOR CURRENT	-XAO	3

INVERTER CUBICLE

ABB
 Prop: Oleq Vanin
 App: Mika Askari
 Project: ACS880-104
 R6i
 Date: 06.09.2023
 Title: CONTROL BOARD
 Inverter Unit
 ACS880-104-0140A-5-F272-V992
 Date: 07.09.2023
 Item Des: FFS2
 = 11
 + 11.1
 SAP Doc. No.: DMS doc. nr. 3AND10000615733
 EPLAN Doc. No.: 3AFE
 ABB Ref. No.:
 Resp. Dept.:
 Rev.:
 Sheet: 040c
 No. of Sheets: 6

■ Frame R6i – Sheet 041a

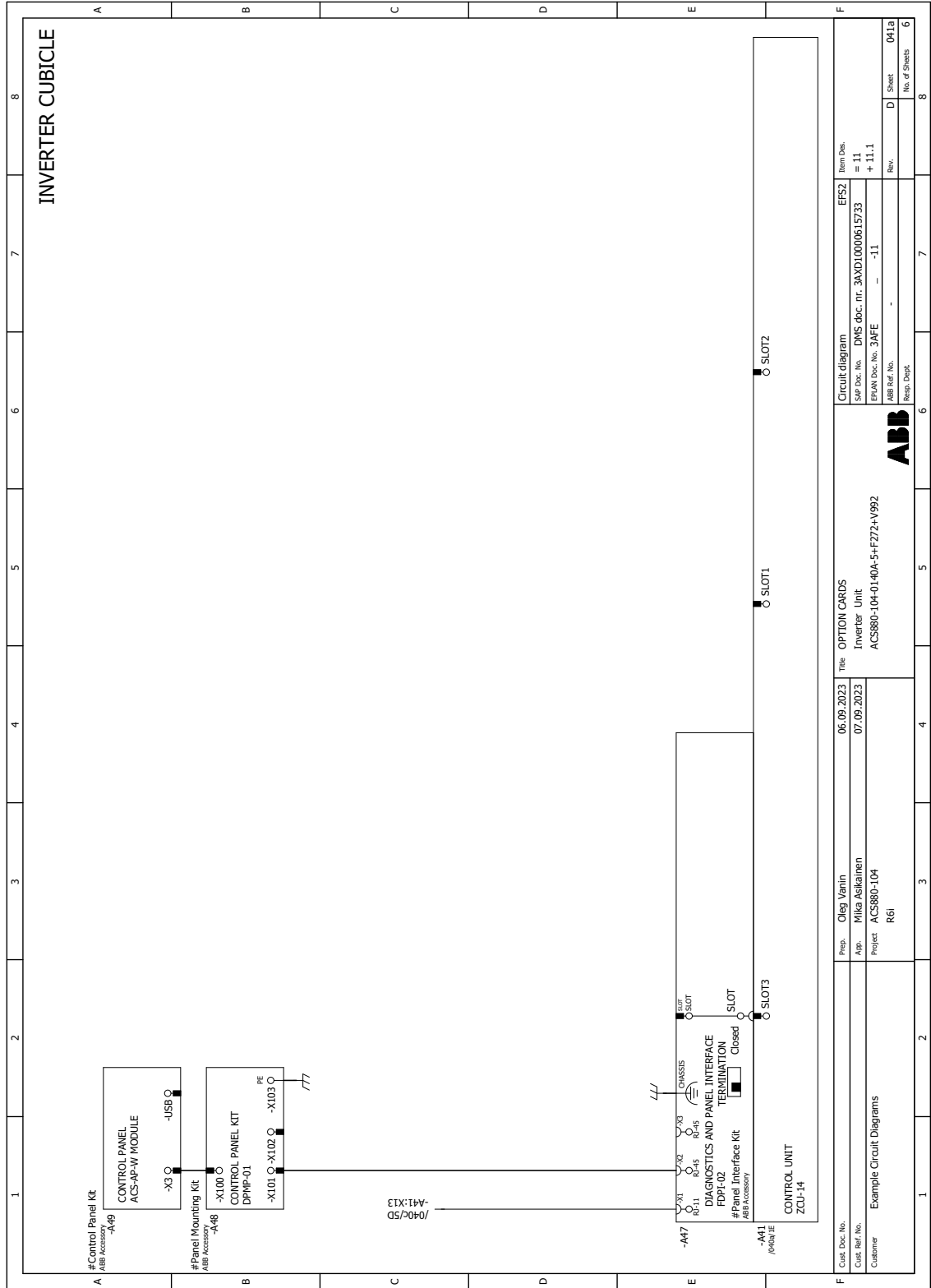

Cost. Doc. No.	06.09.2023	Prep.	Oleg Vanin	Title	OPTION CARDS	Circuit diagram	Item Des.
Customer	Example Circuit Diagrams	App.	Mika Asikainen	Inverter Unit	ACS880-104-0140A-5H-F72+V92	SAP Doc. No.	EFS2
		Project	ACS880-104	R6i		EPAN Doc. No.	3AXD10000615733
						ABB Ref. No.	-11
						Resp. Dept.	+ 11.1
							Rev.
							D
							Sheet
							041a
							No. of Sheets
							8

■ Frame R7i – Sheet 000B

1	2	3	4	5	6	7	8																																									
Higher-level function	Page	Page description						Revision																																								
	000A	Title page / cover sheet						B																																								
	000C	Structured identifier overview						B																																								
	000D	Summarized parts list						B																																								
	300A	Symbol Overview						B																																								
	11	001a	MAIN CIRCUIT						B																																							
		005a	MODULE CONTROL CONNECTIONS						B																																							
		020a	AUXILIARY VOLTAGE DISTRIBUTION						B																																							
		040a	CONTROL BOARD						B																																							
		040b	CONTROL BOARD						B																																							
		040c	CONTROL BOARD						B																																							
	041a	OPTION CARDS						B																																								
<table border="1" style="width: 100%; border-collapse: collapse;"> <tr> <td style="width: 20%;">Cust. Doc. No.</td> <td style="width: 20%;"></td> <td style="width: 20%;">Circuit diagram</td> <td style="width: 20%;">EFSZ</td> <td style="width: 20%;">Item Des.</td> </tr> <tr> <td>Cust. Ref. No.</td> <td></td> <td>SAP Doc. No.</td> <td>DMS doc. nr. 3AXD10000909805</td> <td>=</td> </tr> <tr> <td>Customer</td> <td>Example Circuit Diagrams</td> <td>EPAN Doc. No.</td> <td>3AFE</td> <td>+</td> </tr> <tr> <td></td> <td></td> <td>ABB Ref. No.</td> <td></td> <td>Rev.</td> </tr> <tr> <td></td> <td></td> <td>Resp. Dept.</td> <td></td> <td></td> </tr> <tr> <td>1</td> <td>2</td> <td>3</td> <td>4</td> <td>5</td> <td>6</td> <td>7</td> <td>8</td> </tr> <tr> <td></td> <td></td> <td></td> <td></td> <td></td> <td style="text-align: center;">ABB</td> <td></td> <td style="text-align: right;">B Sheet 000B No. of Sheets 5</td> </tr> </table>								Cust. Doc. No.		Circuit diagram	EFSZ	Item Des.	Cust. Ref. No.		SAP Doc. No.	DMS doc. nr. 3AXD10000909805	=	Customer	Example Circuit Diagrams	EPAN Doc. No.	3AFE	+			ABB Ref. No.		Rev.			Resp. Dept.			1	2	3	4	5	6	7	8						ABB		B Sheet 000B No. of Sheets 5
Cust. Doc. No.		Circuit diagram	EFSZ	Item Des.																																												
Cust. Ref. No.		SAP Doc. No.	DMS doc. nr. 3AXD10000909805	=																																												
Customer	Example Circuit Diagrams	EPAN Doc. No.	3AFE	+																																												
		ABB Ref. No.		Rev.																																												
		Resp. Dept.																																														
1	2	3	4	5	6	7	8																																									
					ABB		B Sheet 000B No. of Sheets 5																																									

■ Frame R7i – Sheet 300A

	1	2	3	4	5	6	7	8
A	GENERAL/RELAY COIL WITH PROTECTIVE CIRCUIT DIODE AND R-LED		NO SWITCH, OPERATED BY TURNING, 2 POSITIONS		PROTECTIVE EARTH CONNECTED TO FRAME		TERMINAL FOUR POLE	
B	GENERAL/RELAY COIL		LIMIT SWITCH NC CONTACT MECHANICALLY OPERATED		PROTECTIVE EARTH CONNECTED TO TERMINAL / PE BUSBAR		PLUG AND SOCKET TERMINAL BLOCK WITH 4 CONNECTION POINTS	
C	COIL WITH PICK-UP DELAY		NC SWITCH, TEMPERATURE OPERATED		FUNCTIONAL EARTHING CONNECTED TO TERMINAL		FEMALE AND MALE PLUG	
D	COIL WITH OFF-DELAY		EMERGENCY STOP PUSH BUTTON		FUNCTIONAL BONDING TO FRAME		AMPERE METER	
E	NO CONTACT		DISCONNECT SWITCH, THREE-POLE		LIGHT		CURRENT TRANSFORMER	
F	NC CONTACT		SWITCH DISCONNECTOR WITH FUSES, THREE-POLE		INDUCTOR		VOLTAGE METER	
G	CHANGE OVER CONTACT		FUSE		CAPACITOR		WIRE TERMINATION, INSULATED	
H	NO CONTACT, WITH CLOSING DELAY		FUSE DISCONNECTOR		RESISTOR		SHIELDED CABLE	
I	TWO NO CONTACTS ONE INPUT, TWO OUTPUTS		CIRCUIT BREAKER		POWER RESISTOR WITH FUSE			
J	TWO CONNECTED CHANGE OVER CONTACTS		MOTOR OVERLOAD SWITCH WITH SWITCH MECHANISM		PHASE SELECTING SWITCH			
K	POWER NO CONTACT OF A CONTACTOR		COMMON MODE FILTER FOR HIGH FREQUENCY CURRENTS		TRANSFORMER		PHASE SELECTING SWITCH	
L	PUSH BUTTON WITH NO CONTACT				EMC FILTER		PHASE SELECTING SWITCH	
M	PUSH BUTTON WITH NC CONTACT						PHASE SELECTING SWITCH	

<p>Customer: Example Circuit Diagrams</p> <p>Cost. Ref. No.:</p> <p>Cost. Doc. No.:</p>	<p>Prep.: Oleg Vanin</p> <p>App.: Mika Asikainen</p> <p>Project: ACS880-104</p> <p>R61</p>	<p>Title: Symbol Overview</p> <p>06.09.2023</p> <p>07.09.2023</p>	<p>Circuit diagram</p> <p>SAP Doc. No. DMS doc. nr. 3AXD.0000615733</p> <p>EPAN Doc. No. 3AFE</p> <p>ABB Ref. No.</p> <p>Resp. Dept.</p>	<p>Item Des. EFSZ</p> <p>=</p> <p>+</p>	<p>300A</p> <p>Sheet</p> <p>No. of Sheets</p>
---	--	---	--	---	---

■ Frame R7i – Sheet 040a

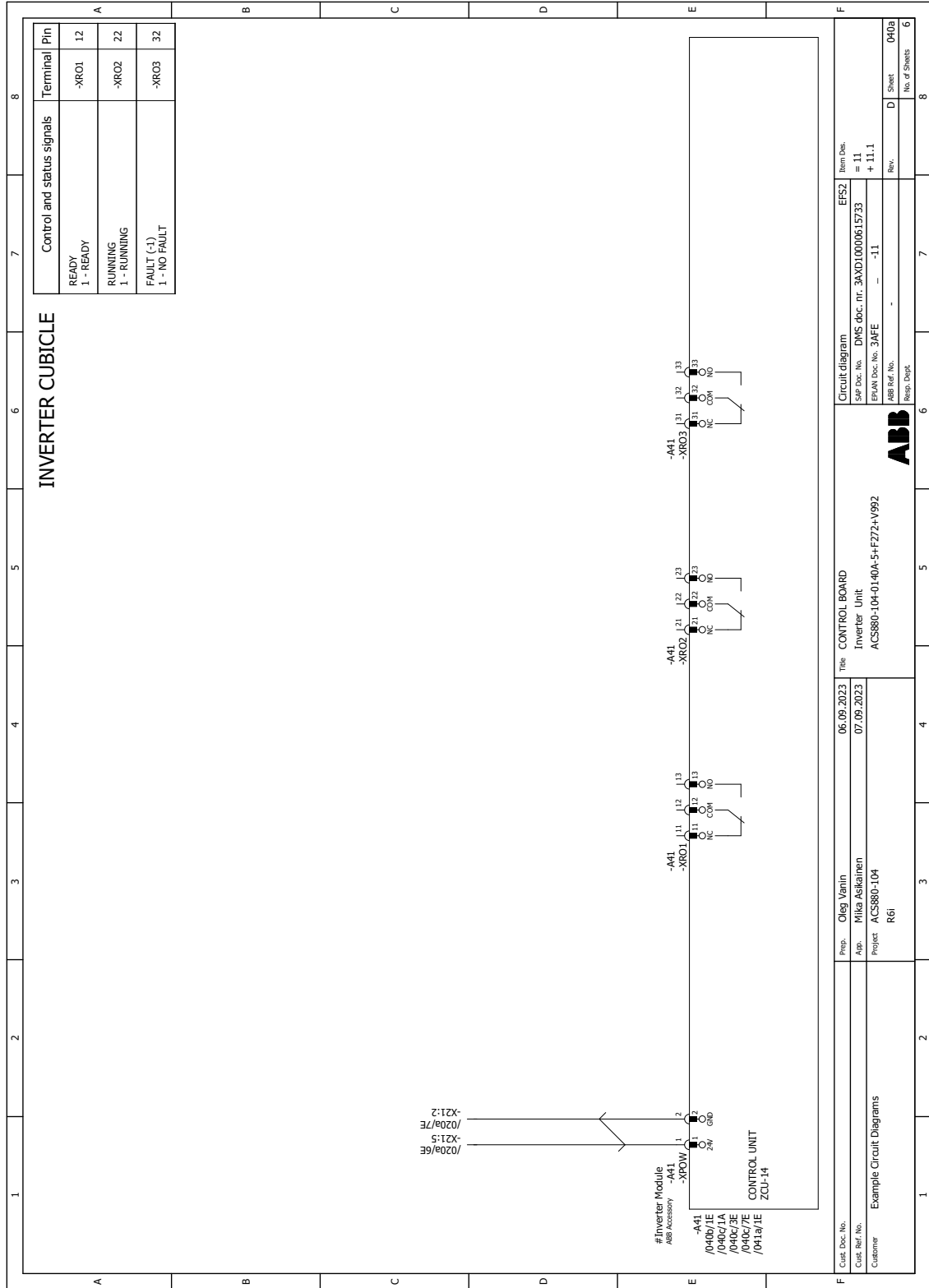

■ Frame R7i – Sheet 040b

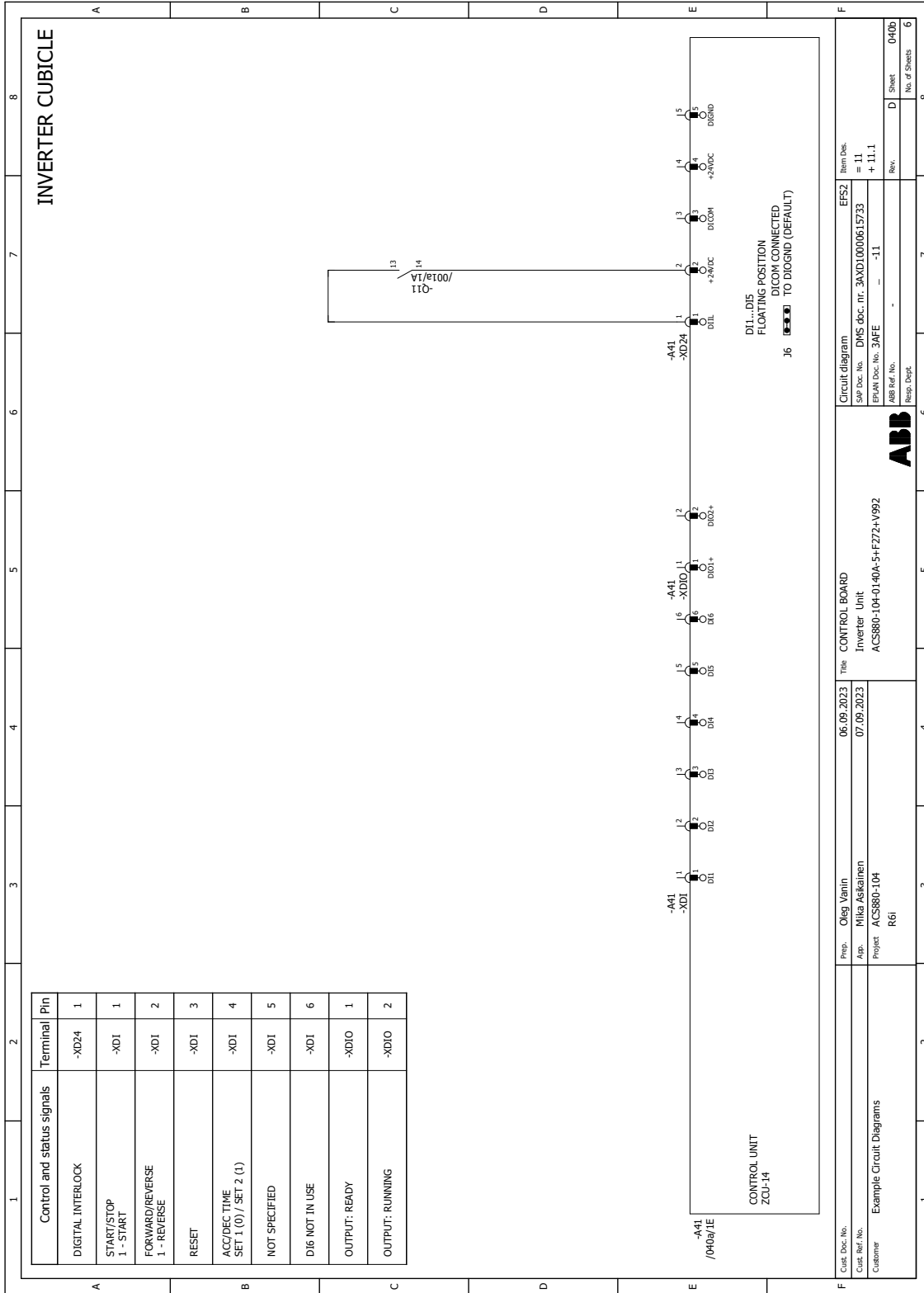

■ Frame R7i – Sheet 040c

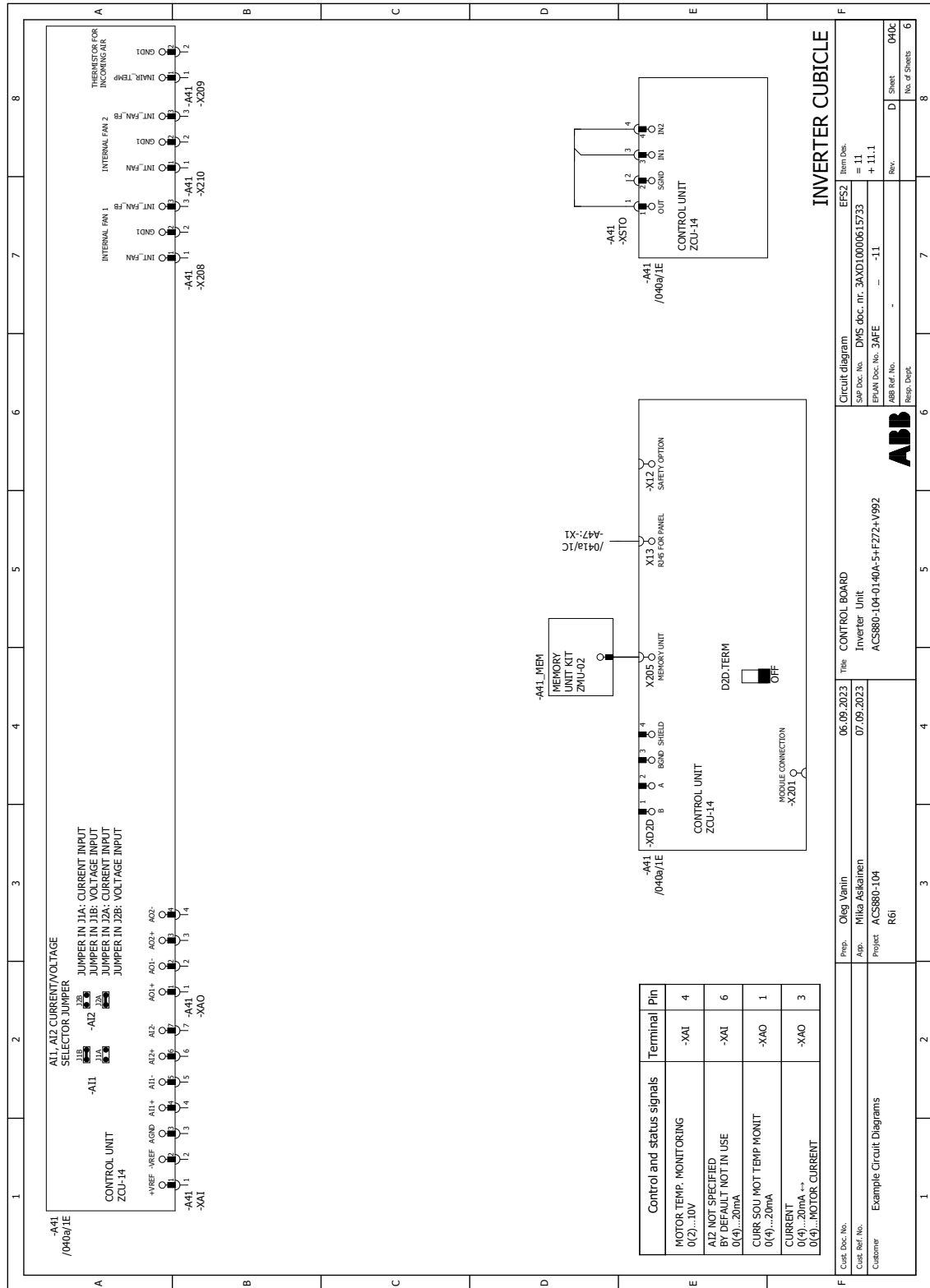

■ Frame R7i – Sheet 041a

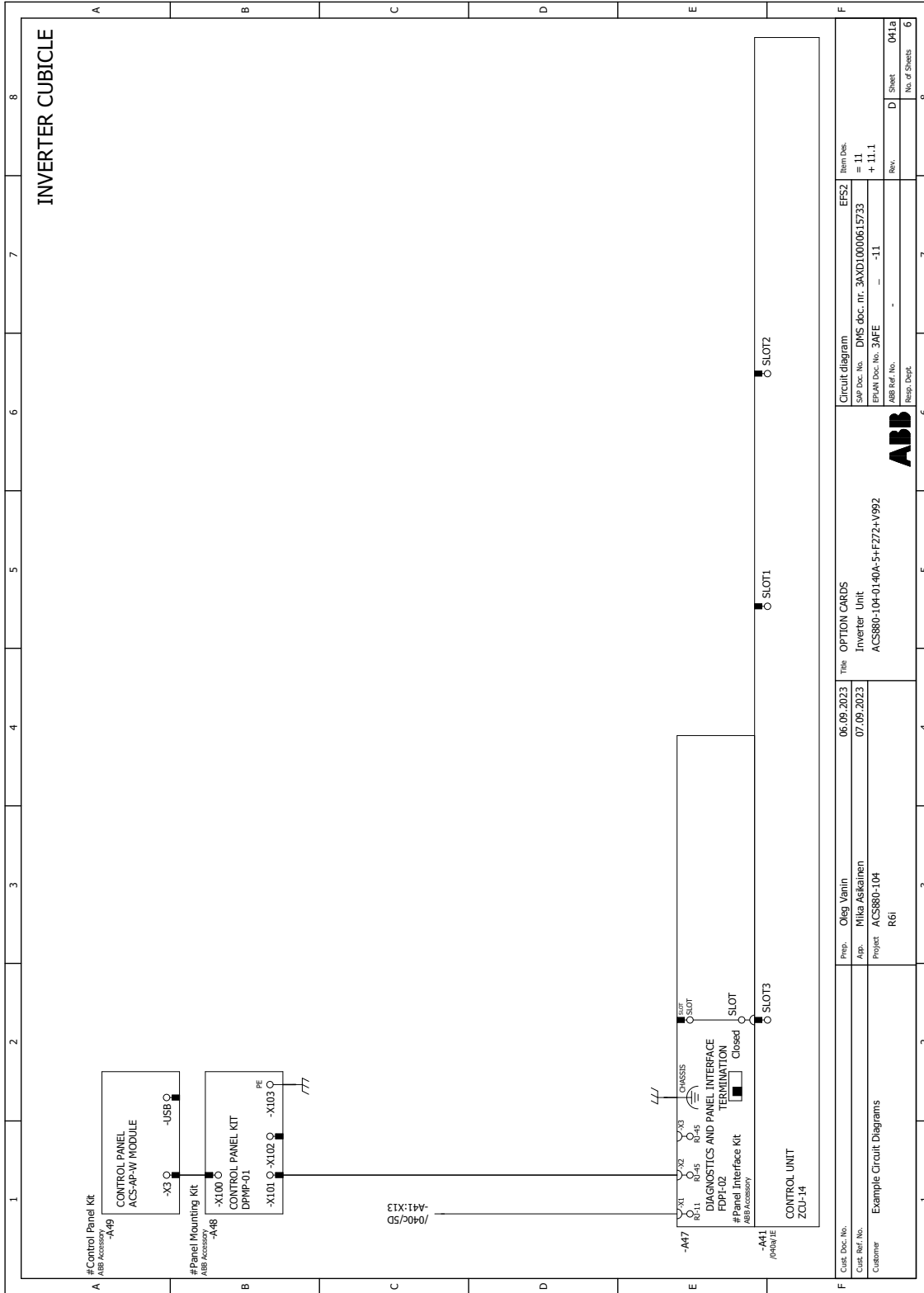

■ Frame R7i – Sheet 001a

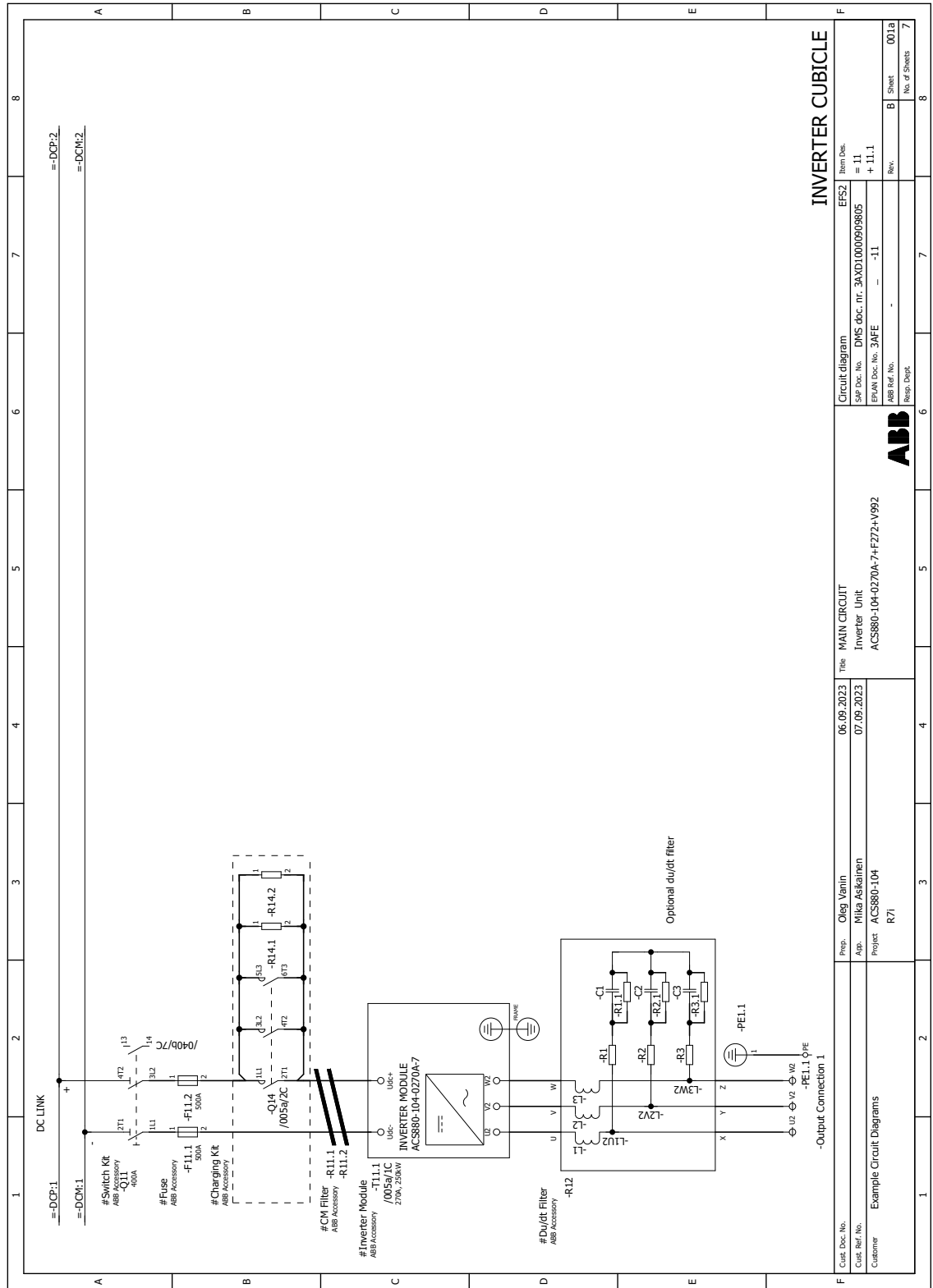

INVERTER CUBICLE

Item No.	EFS2
Rev.	= 11 + 11.1
Item Des.	Circuit diagram
SAP Doc. No.	DMS doc. nr. 3AXD10000909805
EPAN Doc. No.	3AFE
ABB Ref. No.	-
Resp. Dept.	-
Sheet	001a
No. of Sheets	7



MAIN CIRCUIT
Inverter Unit
ACS880-104-0270A-7+F272+V982

Prep. Oleg Vanin
App. Mika Asikainen
Project ACS880-104
R7i

Customer Example Circuit Diagrams

06.09.2023
07.09.2023

■ Frame R7i – Sheet 005a

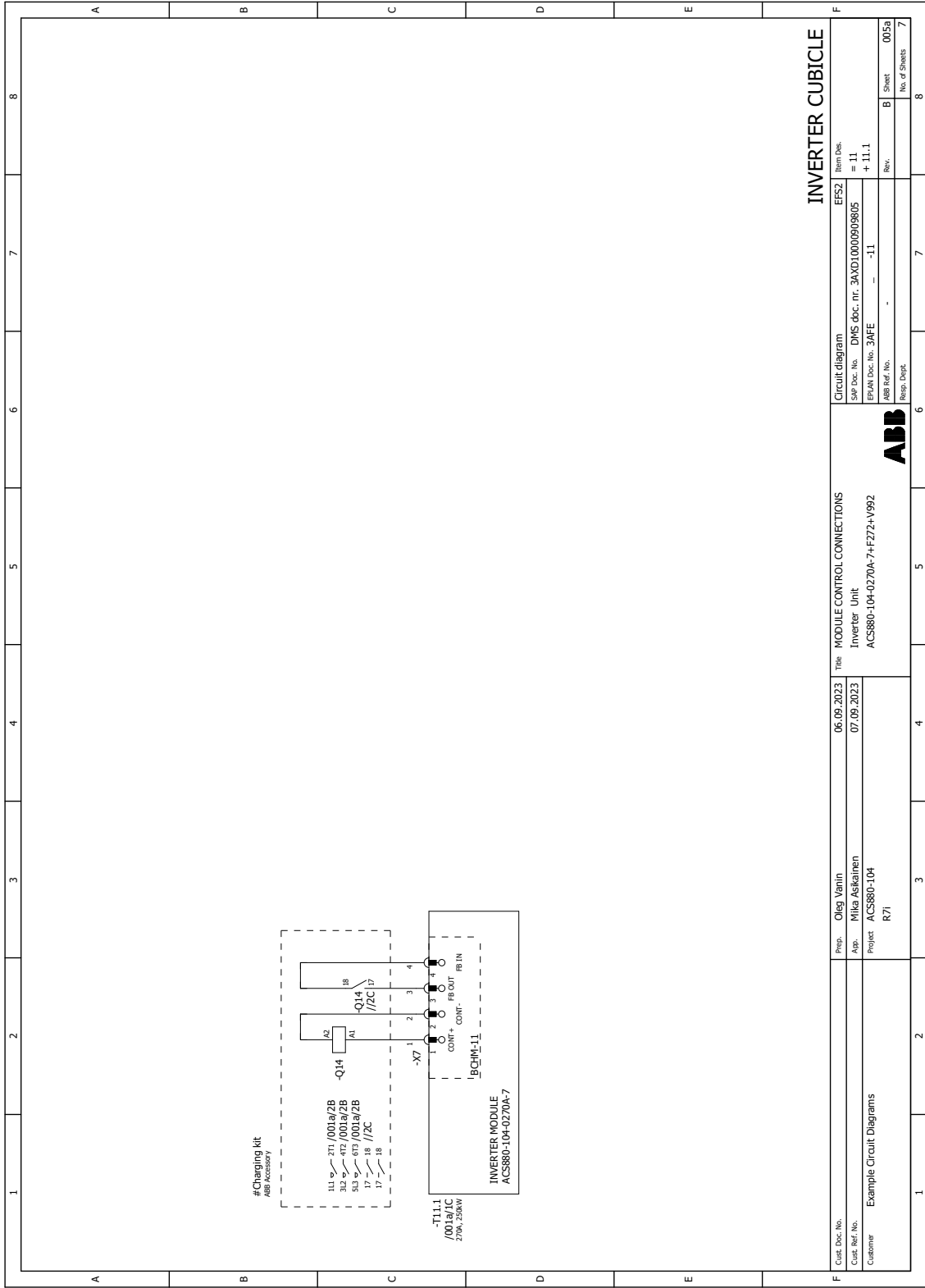

INVERTER CUBICLE

Client Doc. No.	Proj. Oleq. Vanin	Date	06.09.2023	Title	MODULE CONTROL CONNECTIONS	Circuit diagram	Item Des.	EF52
Cost Ref. No.	App. Mita Askarihin	Date	07.09.2023	Inveter Unit	ACS880-104-0270A-7-F272-V992	SAP Doc. No.	DMS doc. nr. 3AXDI0000909805	= 11
Customer	Project ACS880-104					EPAN Doc. No.	3AFE	+ 11.1
	R7i					ABB Ref. No.	-	Rev.
						Resp. Dept.		B
								No. of Sheets
								7



Frame 1xR8i

- Frame 1xR8i (with DC switch/disconnector) – Sheet 000A

■ Frame 1xR8i – Sheet 001a

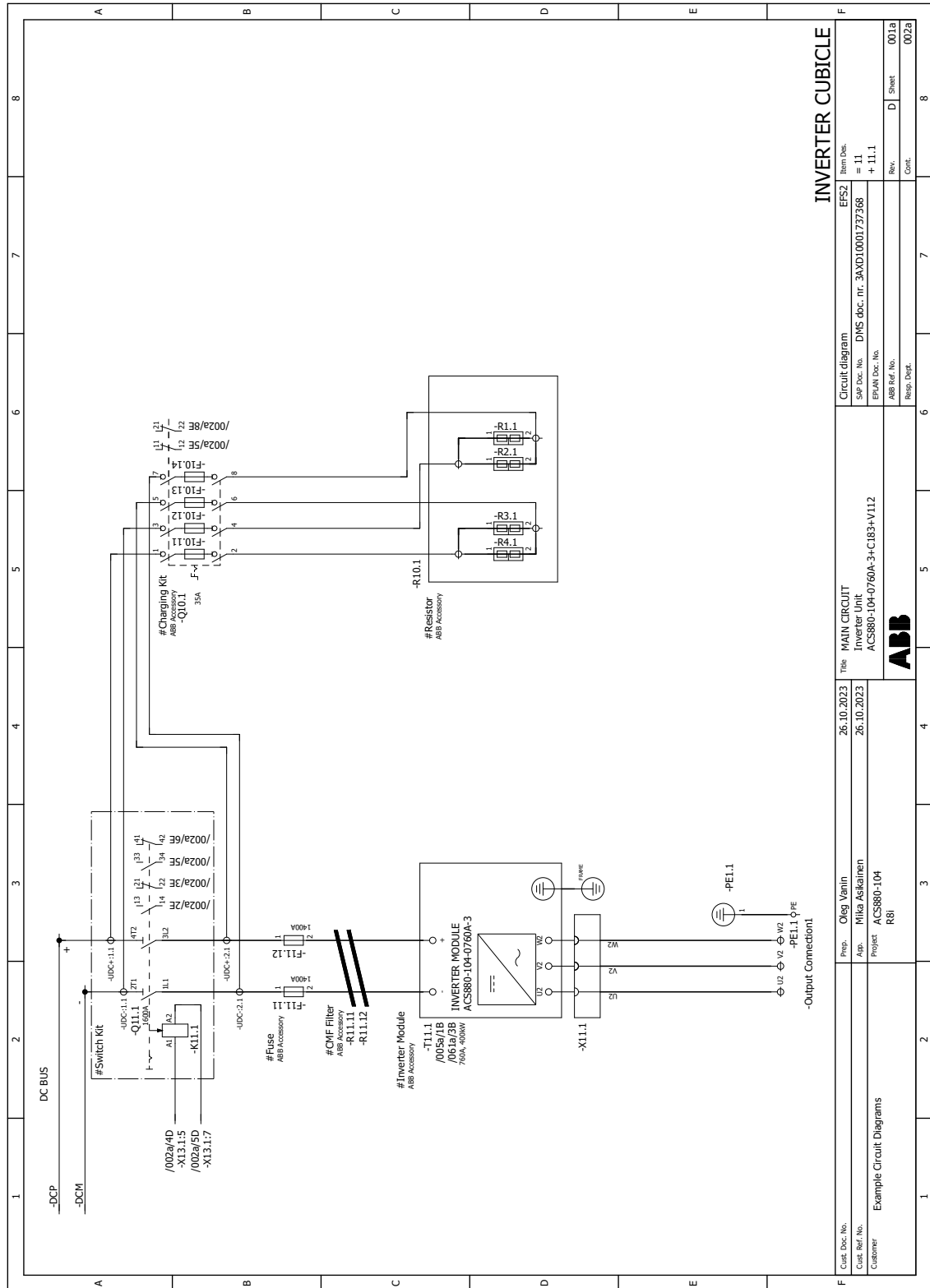

INVERTER CUBICLE

Cost. Doc. No.	Prep.	Oleg Vanin	Title	26.10.2023	MAIN CIRCUIT	Circuit diagram	Item Dis.
Cost. Ref. No.	App.	Mika Asikainen	26.10.2023	Inverter Unit	ACS880-104-0760A-3-C183-V112	SWP Doc. No.	EFS2
Customer	Project	ACS880-104 R8i				DMS doc. nr.	3AXD10001737368
						EPAN Doc. No.	= 11
						ABB Ref. No.	+ 11.1
						Resp. Dept.	Cont.
							D Sheet
							001a
							002a

■ Frame 1xR8i – Sheet 002a

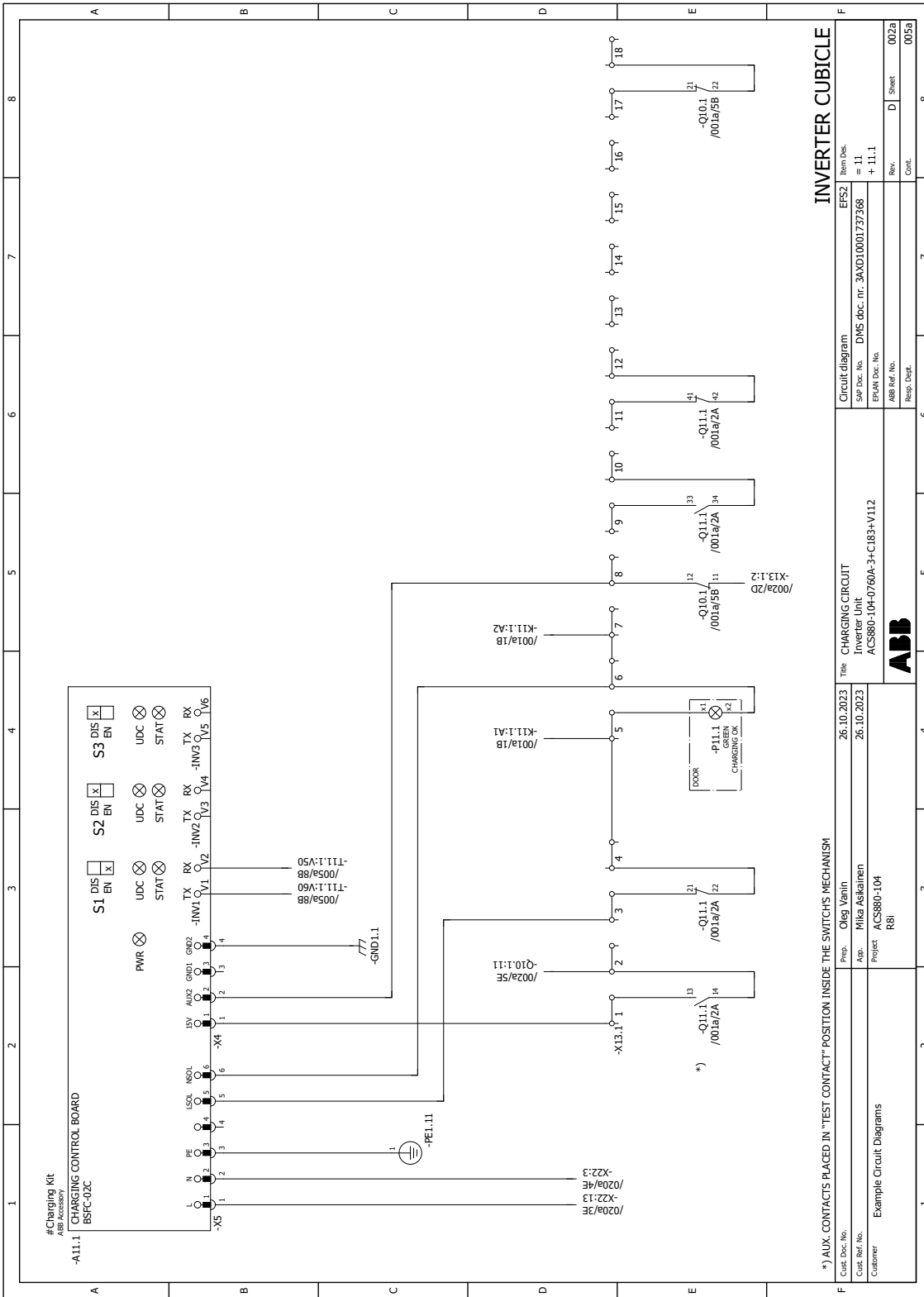

INVERTER CUBICLE

Circuit diagram		EFS2	Item Des.
SAP Doc. No.	DMS doc. nr.	3AXD10001737568	= 11
EPAN Doc. No.		+ 11.1	
ABB Ref. No.			Rev. D Sheet 002a
Resp. Dept.			Cont. 005a
Title		CHARGING CIRCUIT	
Prep.	Olav Vanin	26.10.2023	
App.	Mika Askariinen	26.10.2023	
Customer	Example Circuit Diagrams		
Project	ACS800-104		
	R8i		

*) AUX. CONTACTS PLACED IN "TEST CONTACT" POSITION INSIDE THE SWITCH'S MECHANISM

■ Frame 1xR8i – Sheet 005a

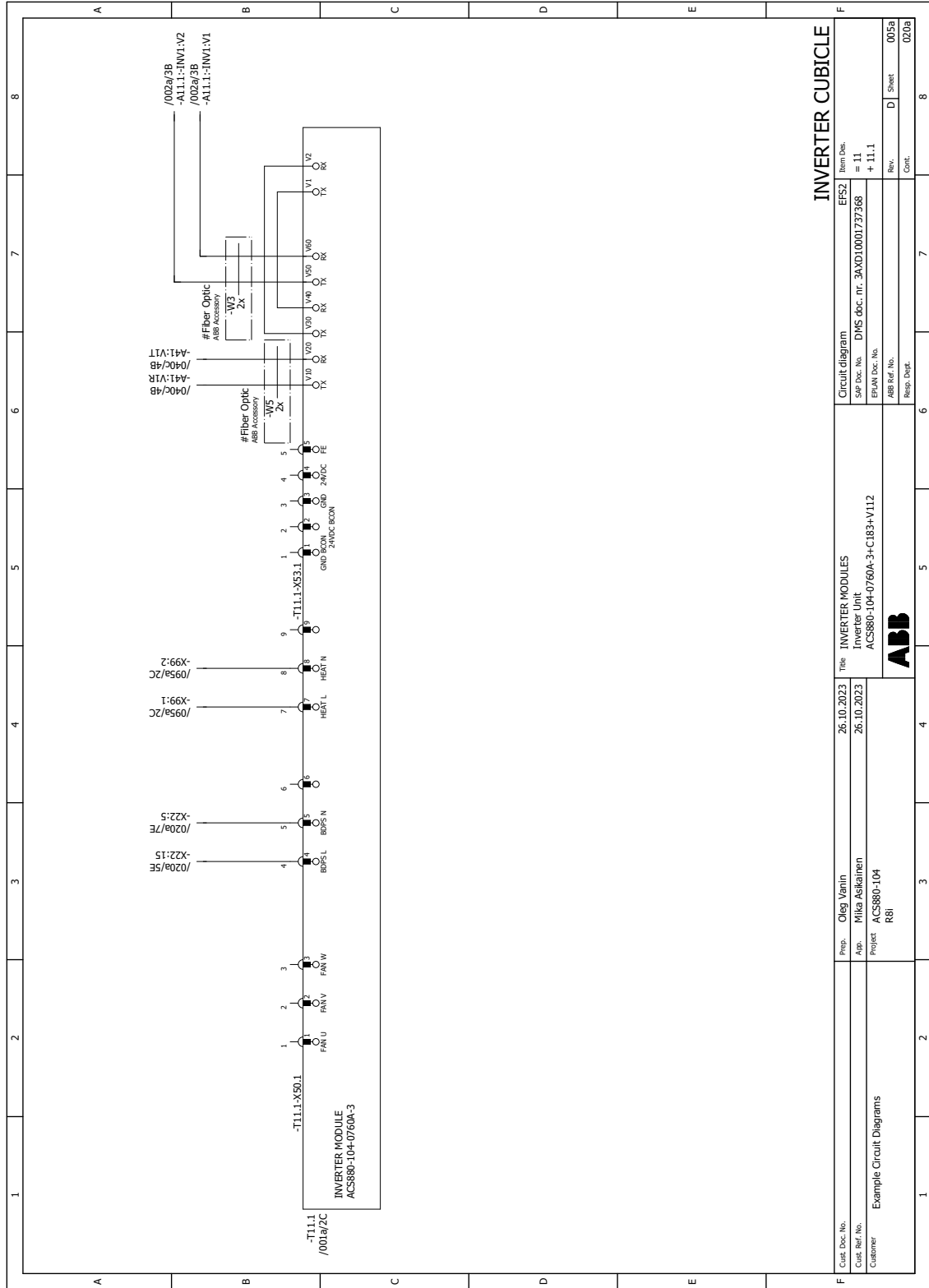

INVERTER CUBICLE

Cost. Doc. No.	Prep.	Oleg Vanin	Title	INVERTER MODULES	Item Des.	EFSZ
Cost. Ref. No.	App.	Mika Asikainen	26.10.2023	Inverter Unit	= 11	
Customer	Project	ACS880-104 R8i	26.10.2023	ACS880-104-0760A-3+C183+V112	+ 11.1	
					Rev.	D Sheet
					Cont.	005a
						020a

■ Frame 1xR8i – Sheet 020a

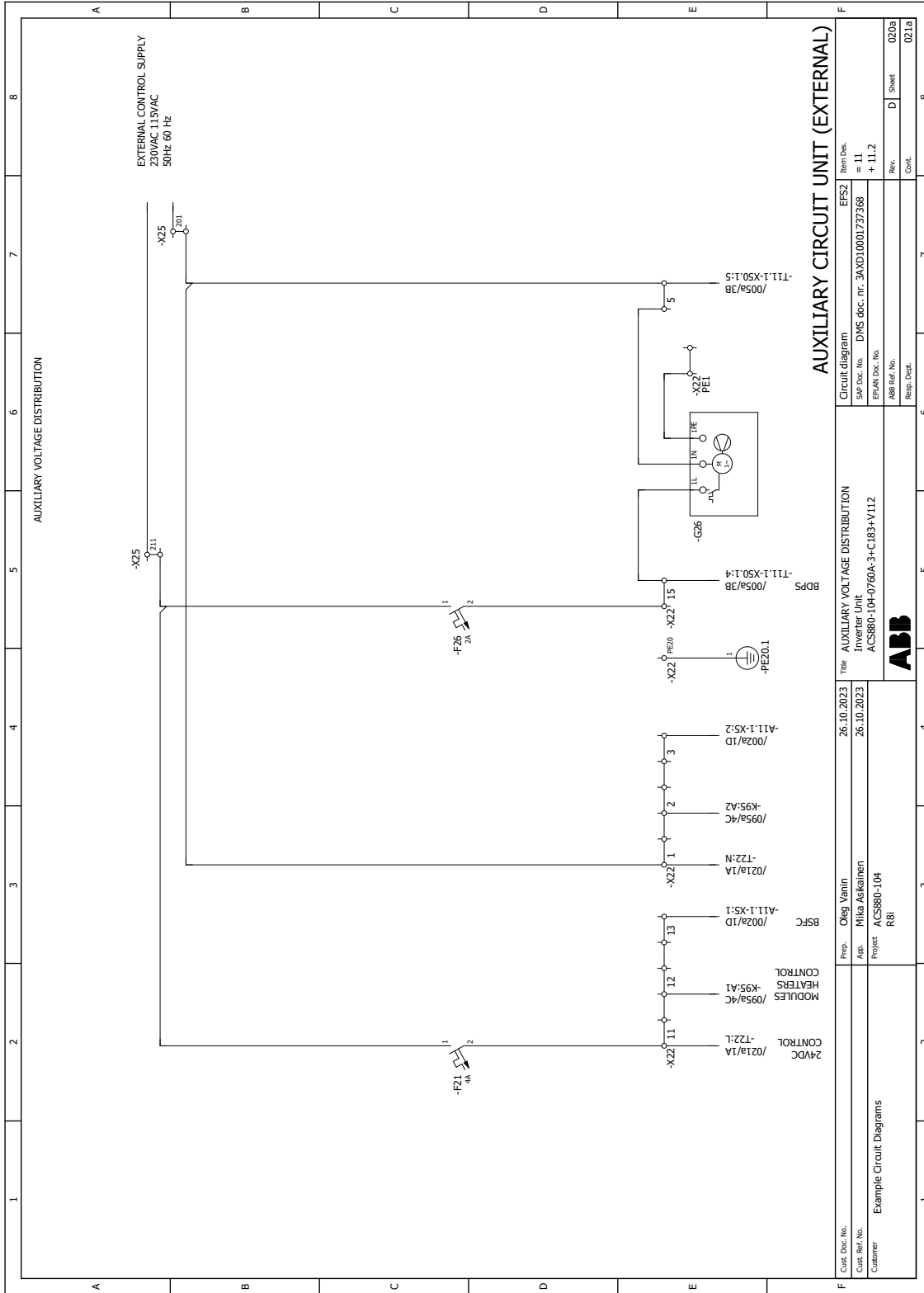

■ Frames 1xR8i and 2xR8i – Sheet 021a

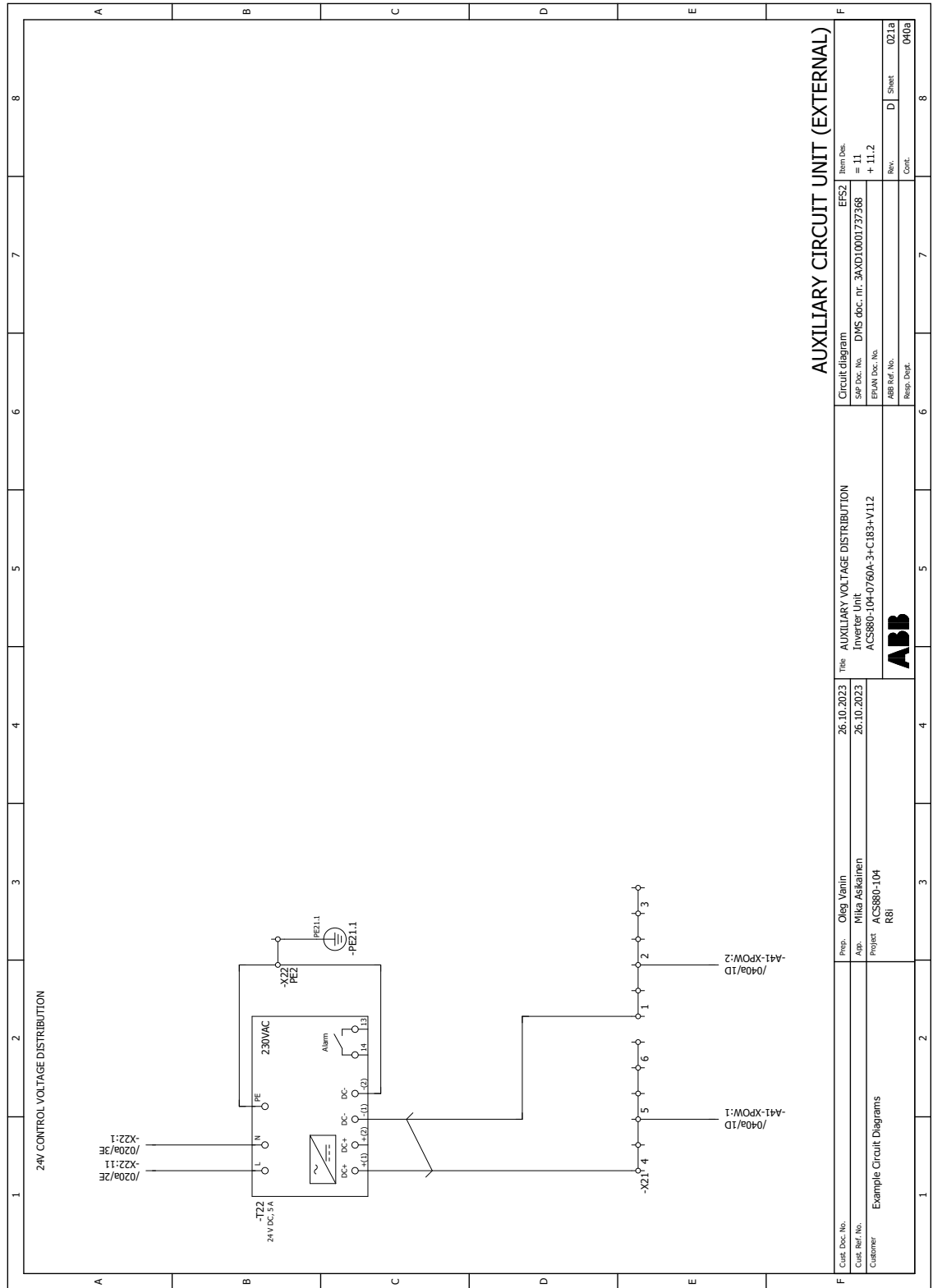

AUXILIARY CIRCUIT UNIT (EXTERNAL)

Cust. Doc. No.		Prep.		Title		Item Des.	
Example Circuit Diagrams		Oleg Vanin		26.10.2023		EFSZ	
		Mika Asikainen		26.10.2023		= 11	
		Project ACS880-104		AUXILIARY VOLTAGE DISTRIBUTION		+ 11.2	
		R8i		Inverter Unit		SWP Doc. No. DMS doc. nr. 3AXD10001737368	
				ACS880-104-0760A-3+C183+V112		EPAN Doc. No.	
				ABB		ABB Ref. No.	
						Resp. Dept.	
						Rev.	
						D Sheet	
						Cont.	
						021a	
						040a	

■ Frames 1xR8i and 2xR8i – Sheet 040a

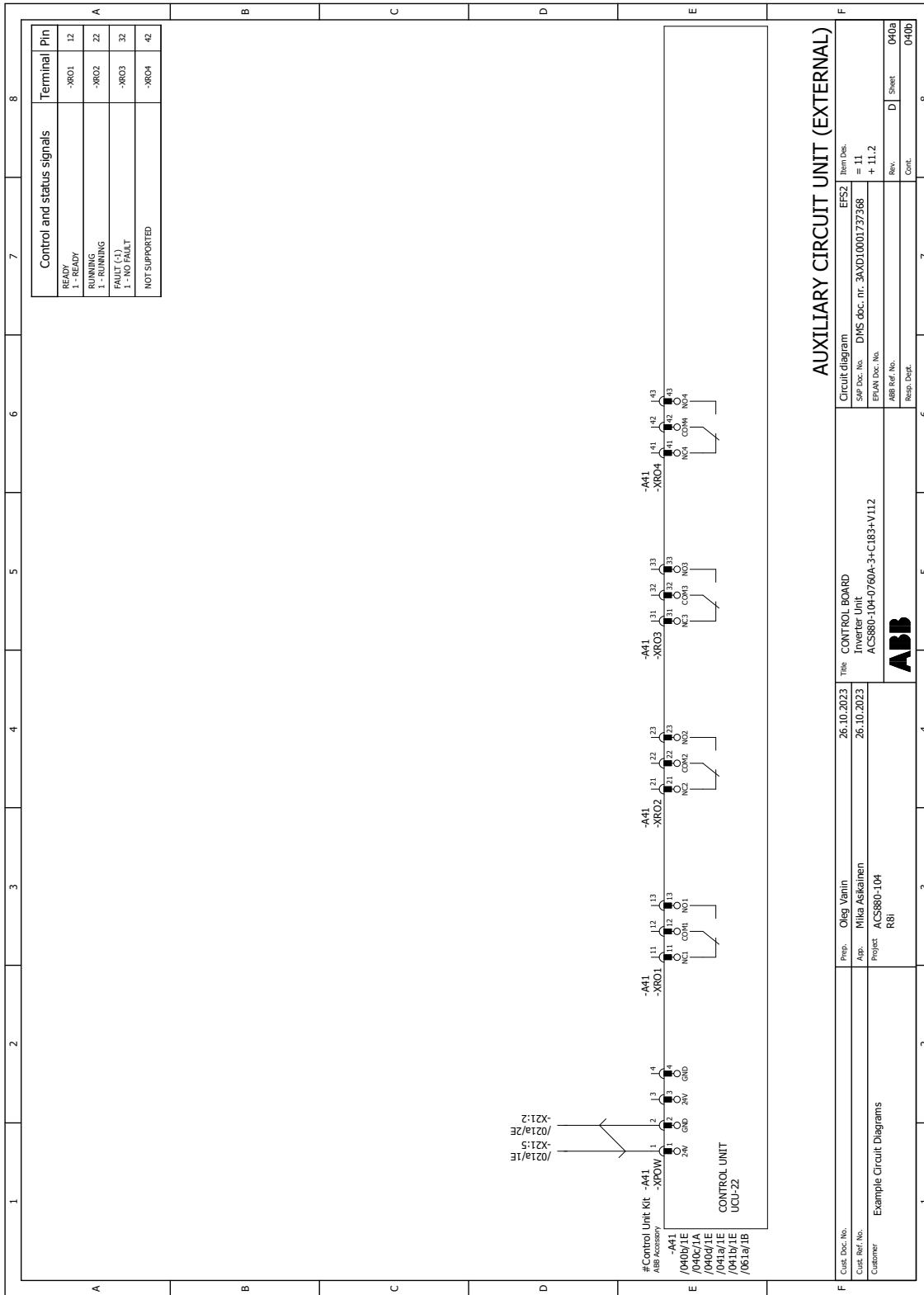

■ Frames 1xR8i and 2xR8i – Sheet 040b

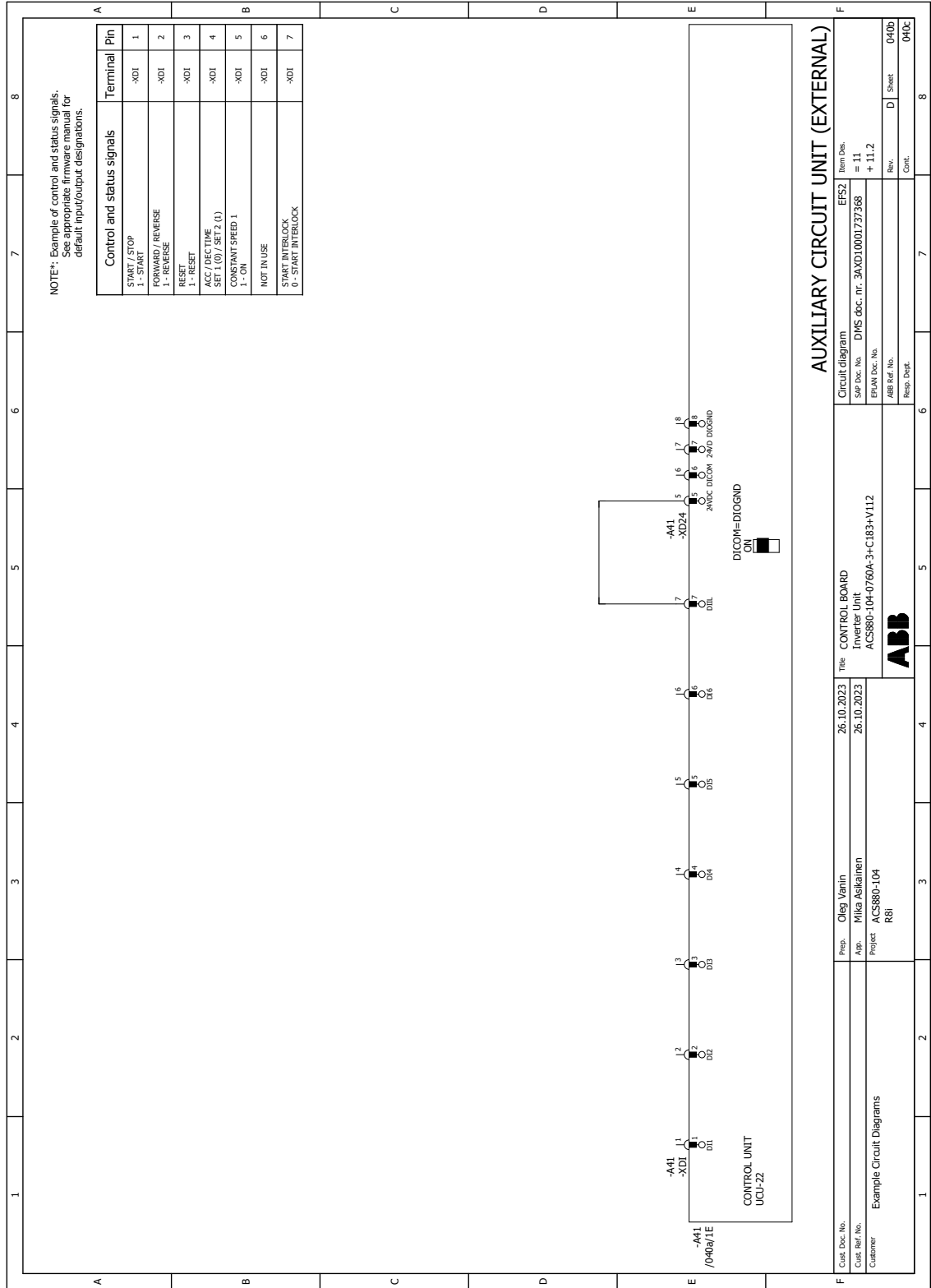

■ Frame 1xR8i – Sheet 040c

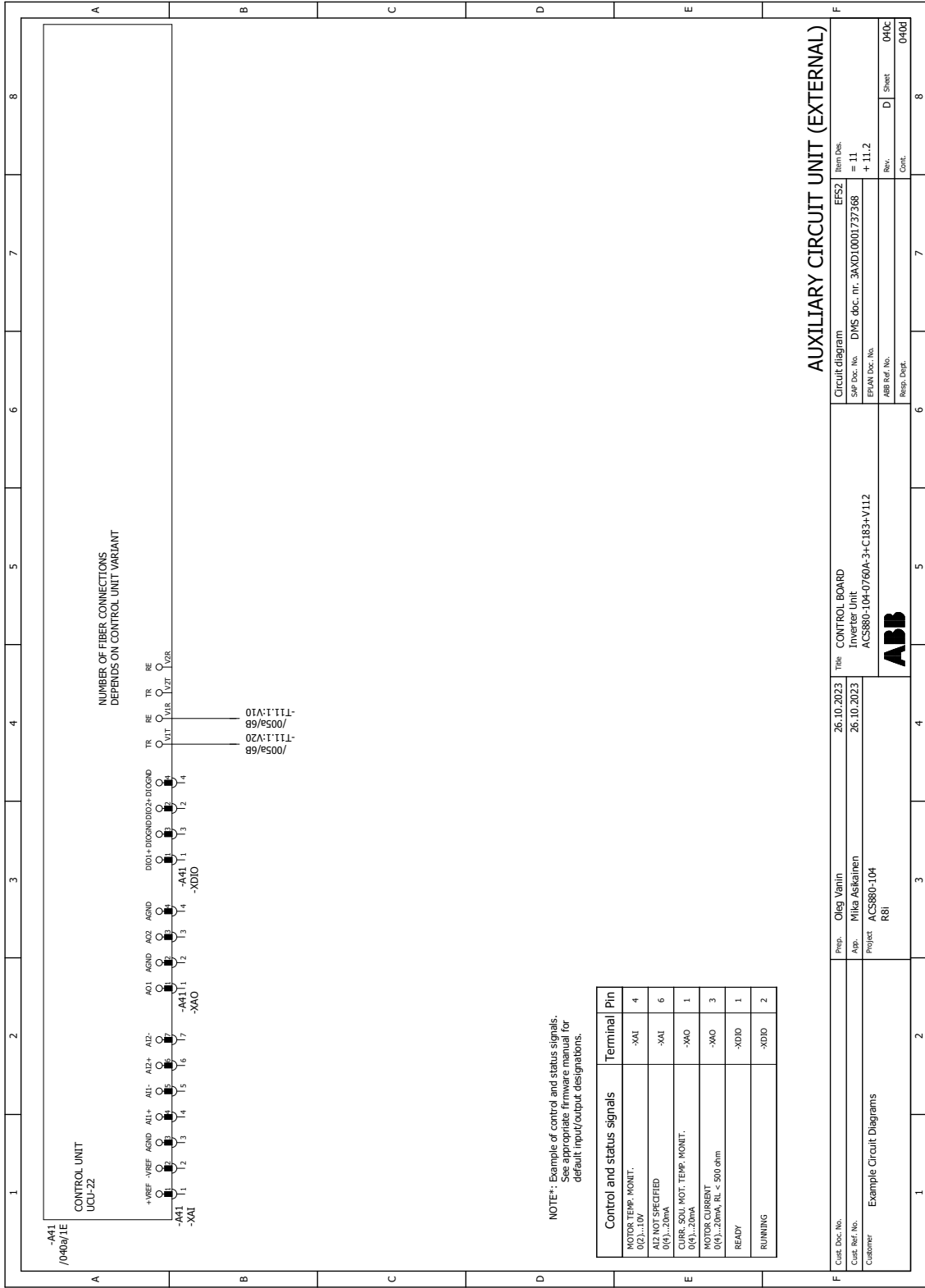

AUXILIARY CIRCUIT UNIT (EXTERNAL)

Customer	Example Circuit Diagrams	
Customer Ref. No.		
Doc. No.	26.10.2023	26.10.2023
Prep.	Oleq Vanin	
App.	Mika Asikainen	
Project	ACS880-104	R8i
Title	CONTROL BOARD	
Process Unit	ACS880-104-0760A-3-C183-V112	
Circuit diagram	EFS2	Item Des.
SAP Doc. No.	DMS doc. nr. 3AXD10001737368	= 11
EPAN Doc. No.		+ 11.2
ABB Ref. No.		Rev.
Resp. Dept.		Cont.
		D Sheet
		040c
		040d

■ Frames 1xR8i and 2xR8i – Sheet 040d

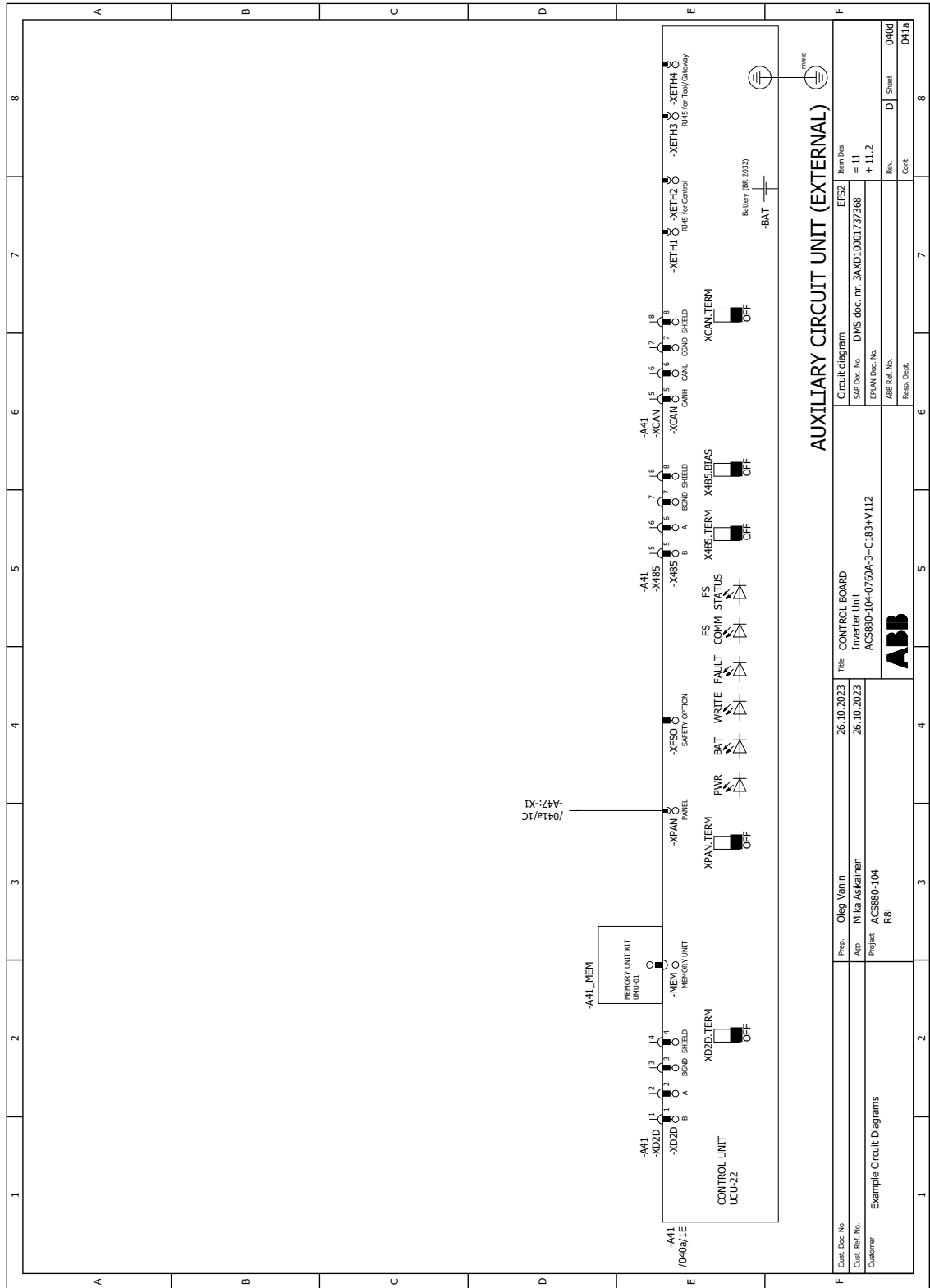

AUXILIARY CIRCUIT UNIT (EXTERNAL)

Cost. Doc. No.	040d
Customer	Example Circuit Diagrams
Prep.	Oleg Vanin
App.	Mika Asikainen
Project	ACS880-104 R8i
Title	CONTROL BOARD
26.10.2023	Inverter Unit
26.10.2023	ACS880-104-0760A-3+C183+V112
Circuit diagram	
Item Des.	EFSZ
SWP Doc. No.	DMS doc. nr. 3AXD10001737368
EPAN Doc. No.	= 11
ABB Ref. No.	+ 11.2
Resp. Dept.	
Rev.	D Sheet
Cont.	040d
	041a

■ Frames 1×R8i and 2×R8i – Sheet 041a

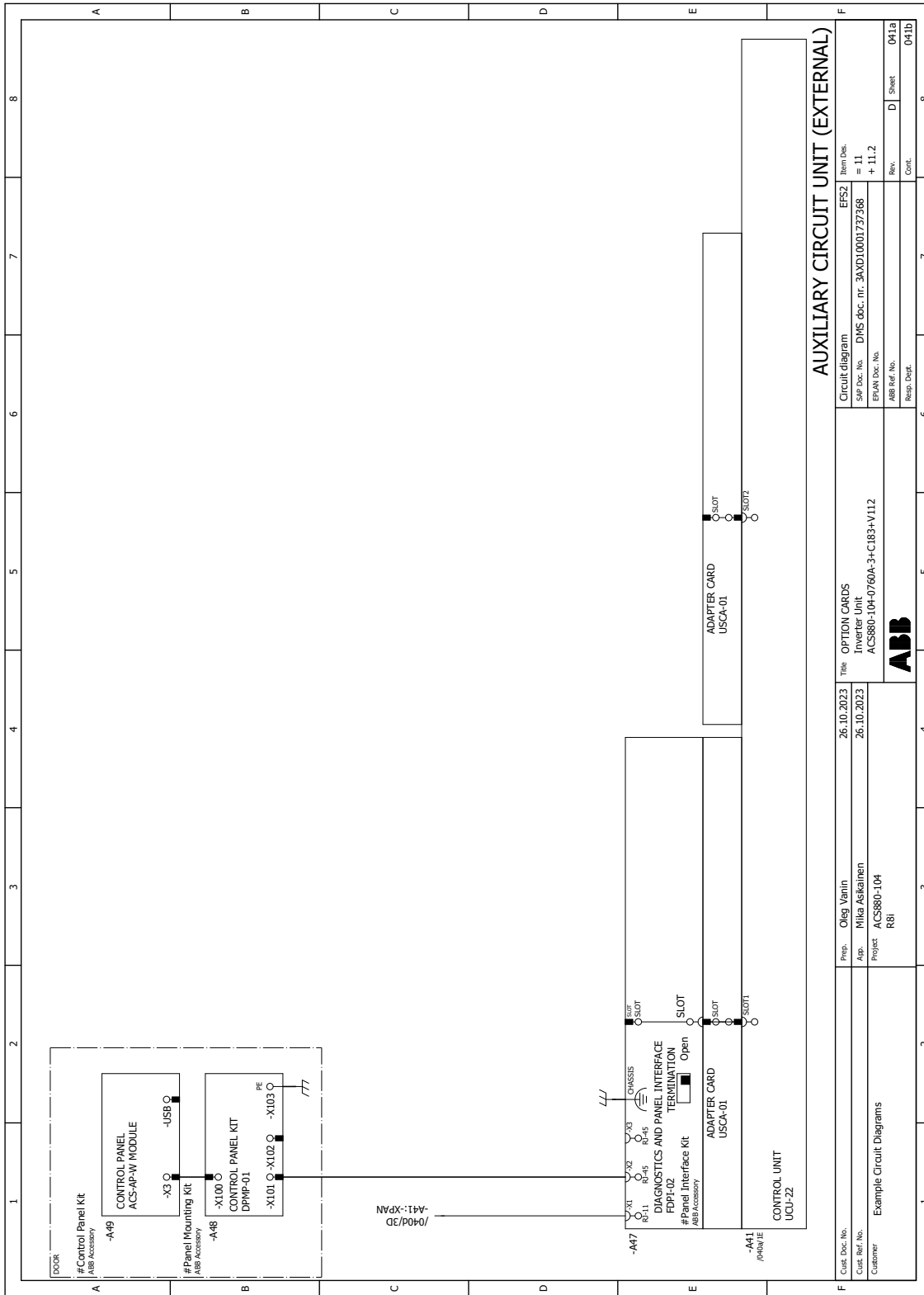

■ Frames 1xR8i and 2xR8i – Sheet 061a

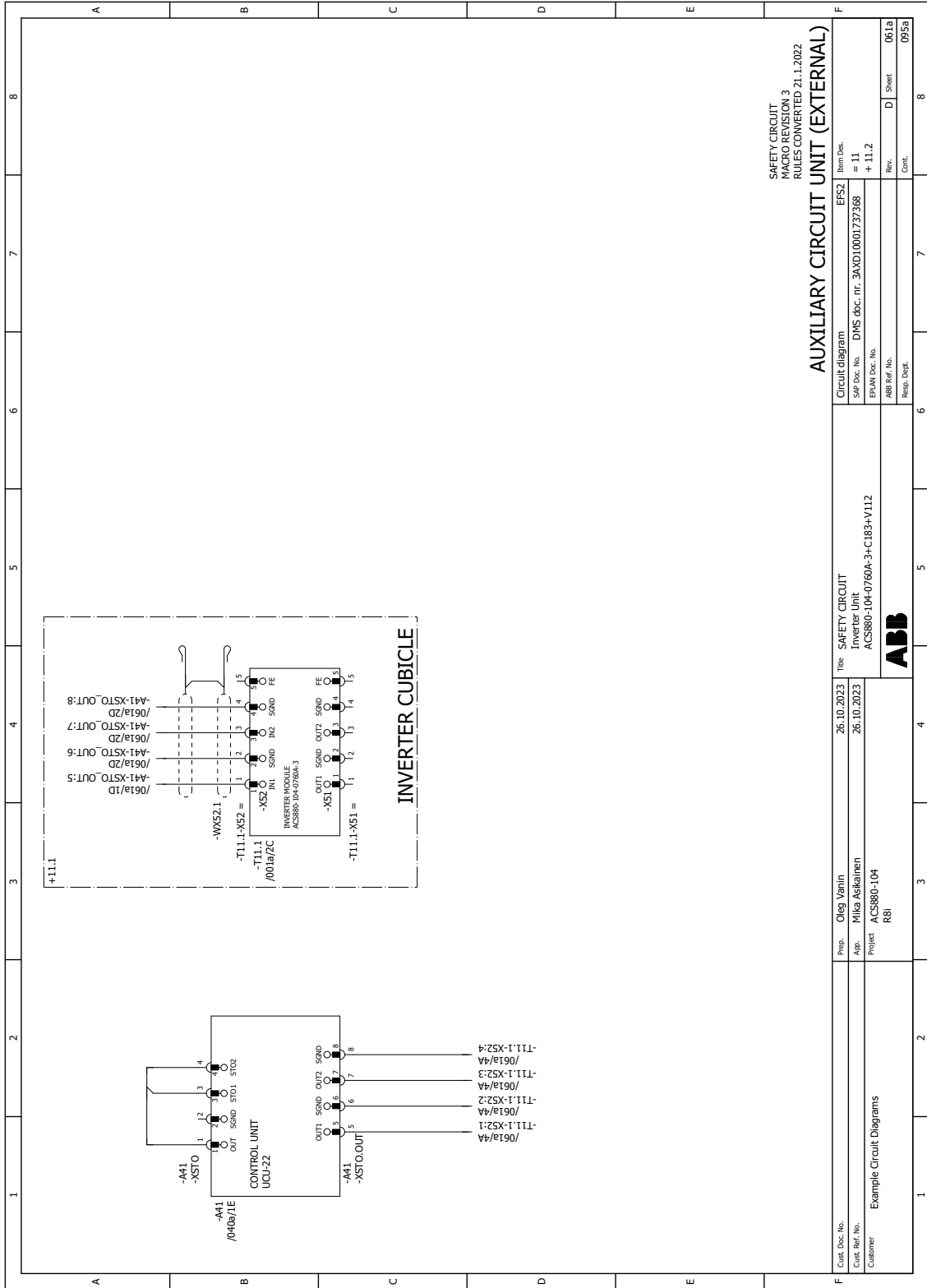

SAFETY CIRCUIT
MACRO REVISION 3
RULES CONVERTED 21.11.2022

AUXILIARY CIRCUIT UNIT (EXTERNAL)

Customer	Example Circuit Diagrams	Prep.	Oleg Vanin	Title	SAFETY CIRCUIT Inverter Unit	Item Des.	EFSZ
Customer Ref. No.		App.	Mika Asikainen	26.10.2023	ACS880-104-0760A-3+C183+V112	SWP Doc. No.	DMS doc. nr. 3AXD10001737368
Customer		Project	ACS880-104 R8i	26.10.2023		EPAN Doc. No.	= 11 + 11.2
						ABB Ref. No.	
						Resp. Dept.	
							Rev. D Sheet 061a
							Cont. 095a



■ Frames 1xR8i and 2xR8i – Sheet 095a

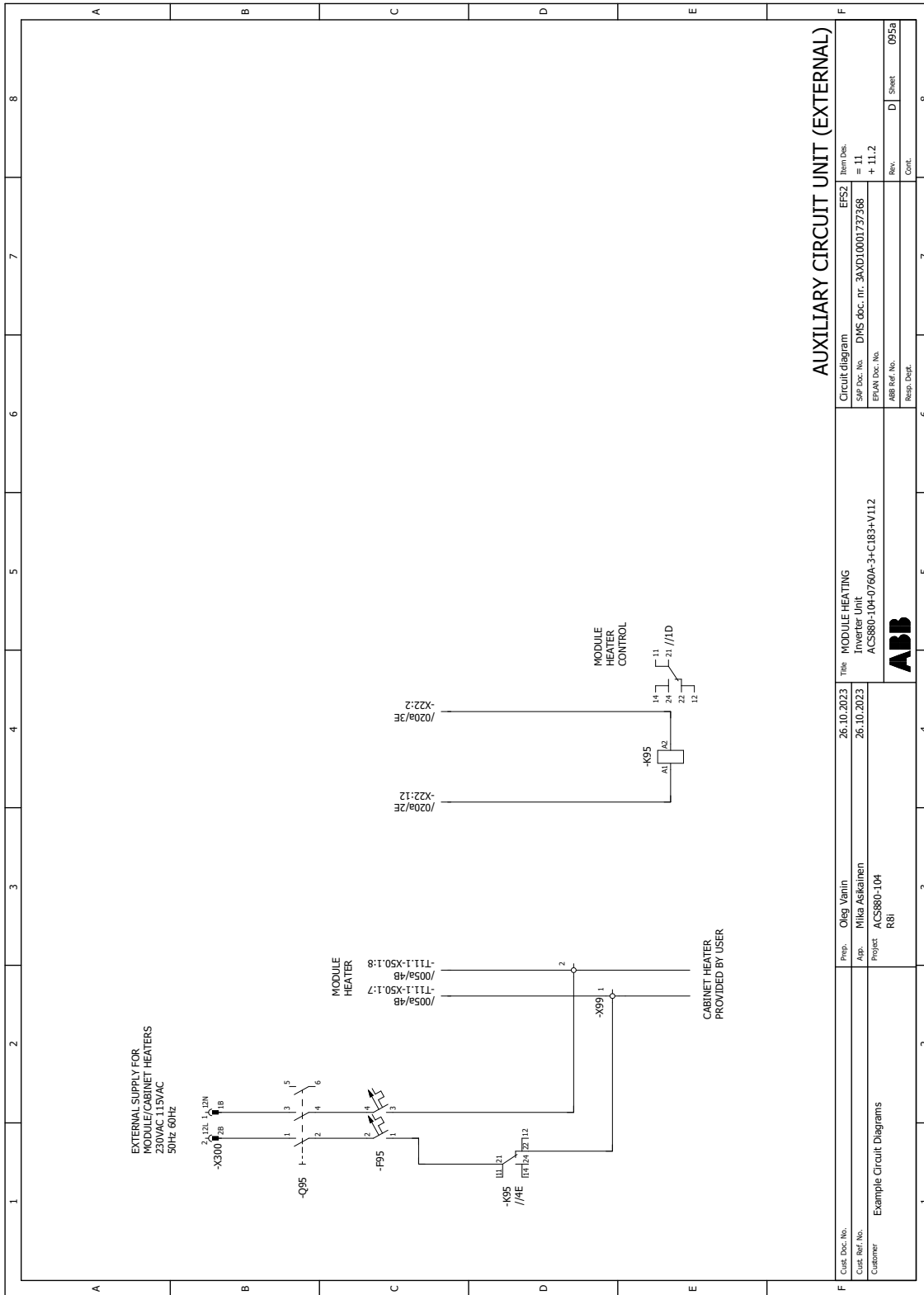

AUXILIARY CIRCUIT UNIT (EXTERNAL)

Client Doc. No.	26.10.2023	Time	26.10.2023	Prep.	Oleg Vanin
Customer	Example Circuit Diagrams	Project	ACS880-104 R8i	App.	Mika Askainen
Item Des.	Circuit diagram	Module Heating	Module Heating	Project	ACS880-104
Rev.	D	Sheet	095a	Project	ACS880-104
Cont.				Project	R8i

■ Frame 2xR8i – Sheet 000B

1		2		3		4		5		6		7		8	
Higher-level function		Page	Page description		Revision										
11		000A	Title page / cover sheet		E										
		000C	Structured Identifier overview		E										
		000D	Summarized parts list		E										
		200A	Overview diagram		E										
		300A	Symbol Overview		E										
		001a	MAIN CIRCUIT		E										
		005a	INVERTER MODULES		E										
		020a	AUXILIARY VOLTAGE DISTRIBUTION		E										
		021a	AUXILIARY VOLTAGE DISTRIBUTION		E										
		040a	CONTROL BOARD		E										
		040b	CONTROL BOARD		E										
040c	CONTROL BOARD		E												
040d	CONTROL BOARD		E												
041a	OPTION CARDS		E												
041b	OPTION CARDS		E												
061a	SAFETY CIRCUIT		E												
095a	MODULE HEATING		E												
D															
E															
F															
Customer No.		Prep: Oleg Vanin		27.10.2023		Title: Table of contents		27.10.2023		Circuit diagram		EFS2		Item Des.	
Doc. Ref. No.		App: Mika Askainen		27.10.2023		Inverter Unit		ACS880-104-1150A-5+E205+CI83+CI88+Y112		SAP Doc. No. DMS doc. nr. 3AXD10001728143		=			
Customer		Project: ACS880-104-2XR8i				ABB				EPAN Doc. No.		+			
										ABB Ref. No.		Rev.		E Sheet 000B	
										Resp. Dept.		Cont.		E Sheet 000C	
1		2		3		4		5		6		7		8	

■ Frame 2xR8i – Sheet 001a

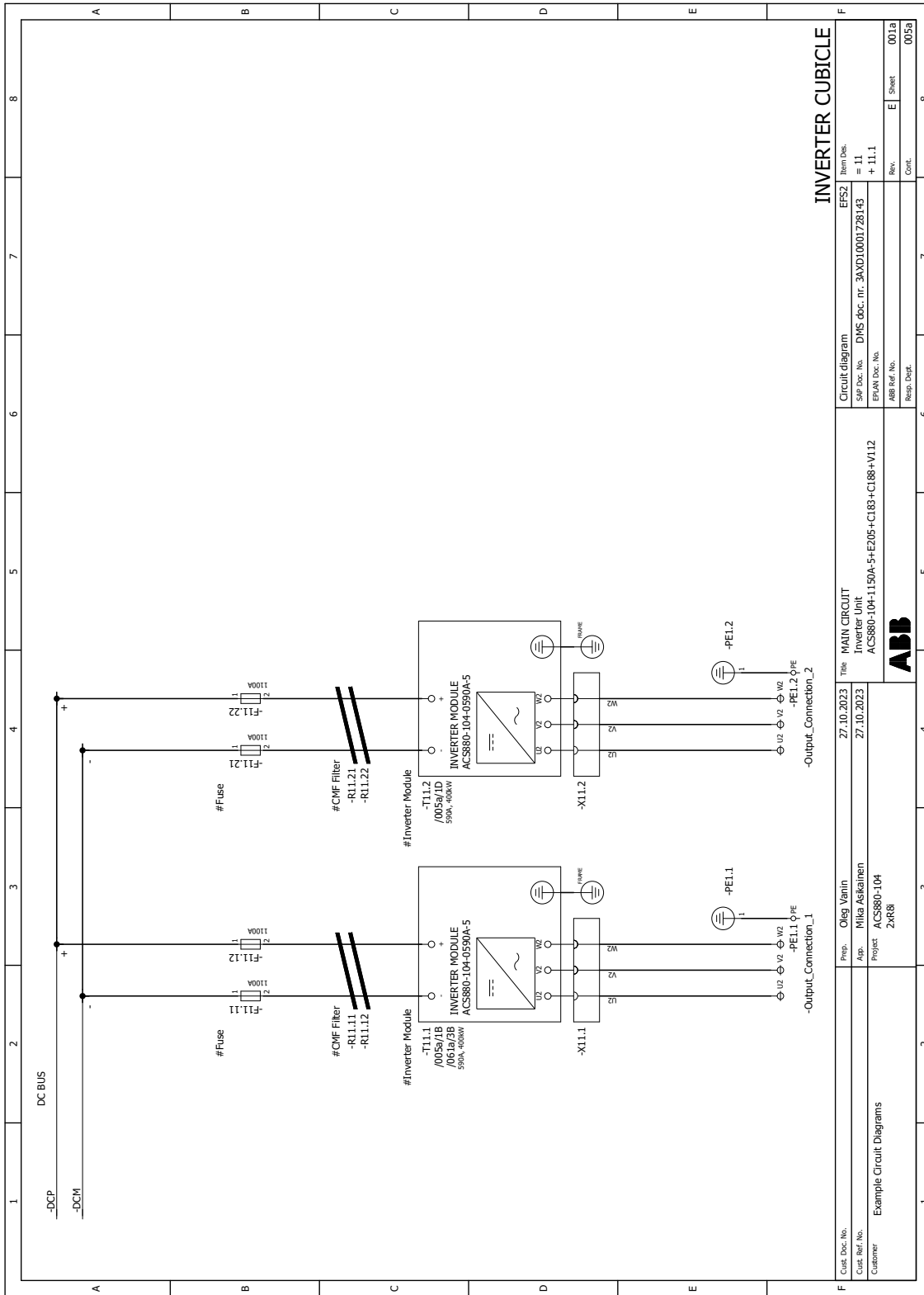

INVERTER CUBICLE

Client Doc. No.	Proj:	Obj:	Time	Item Des.
Example Circuit Diagrams	Oleg Vanin	Mika Askari	27.10.2023	EFCS2
Customer	ACS880-104 2xR8i	ACS880-104-1150A-5+E205+CI83+CI88+Y112	27.10.2023	Item Des. = 11 + 11.1
				Rev.
				Cont.
				001a
				005a

■ Frame 2xR8i – Sheet 005a

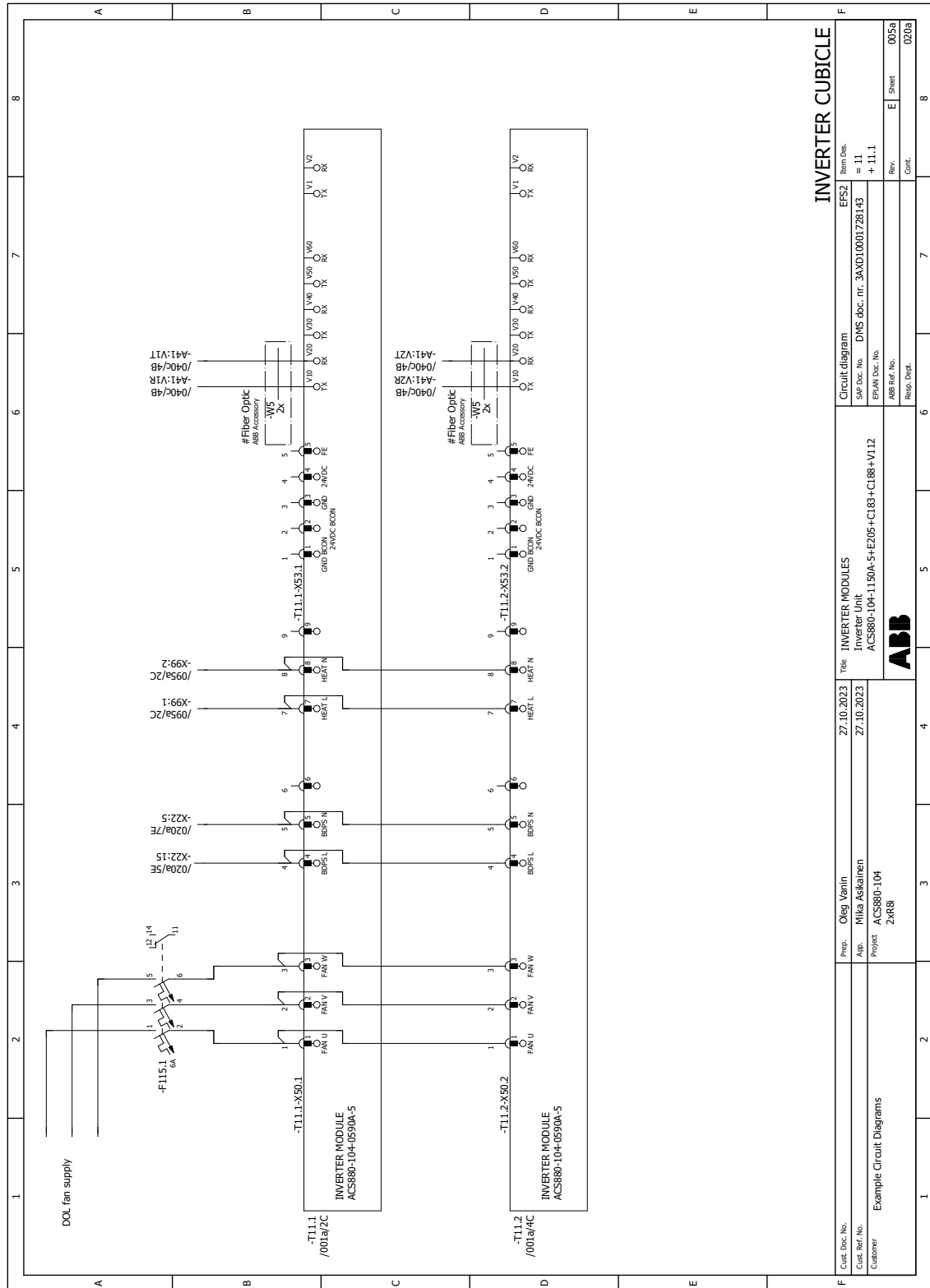

■ Frame 2xR8i – Sheet 020a

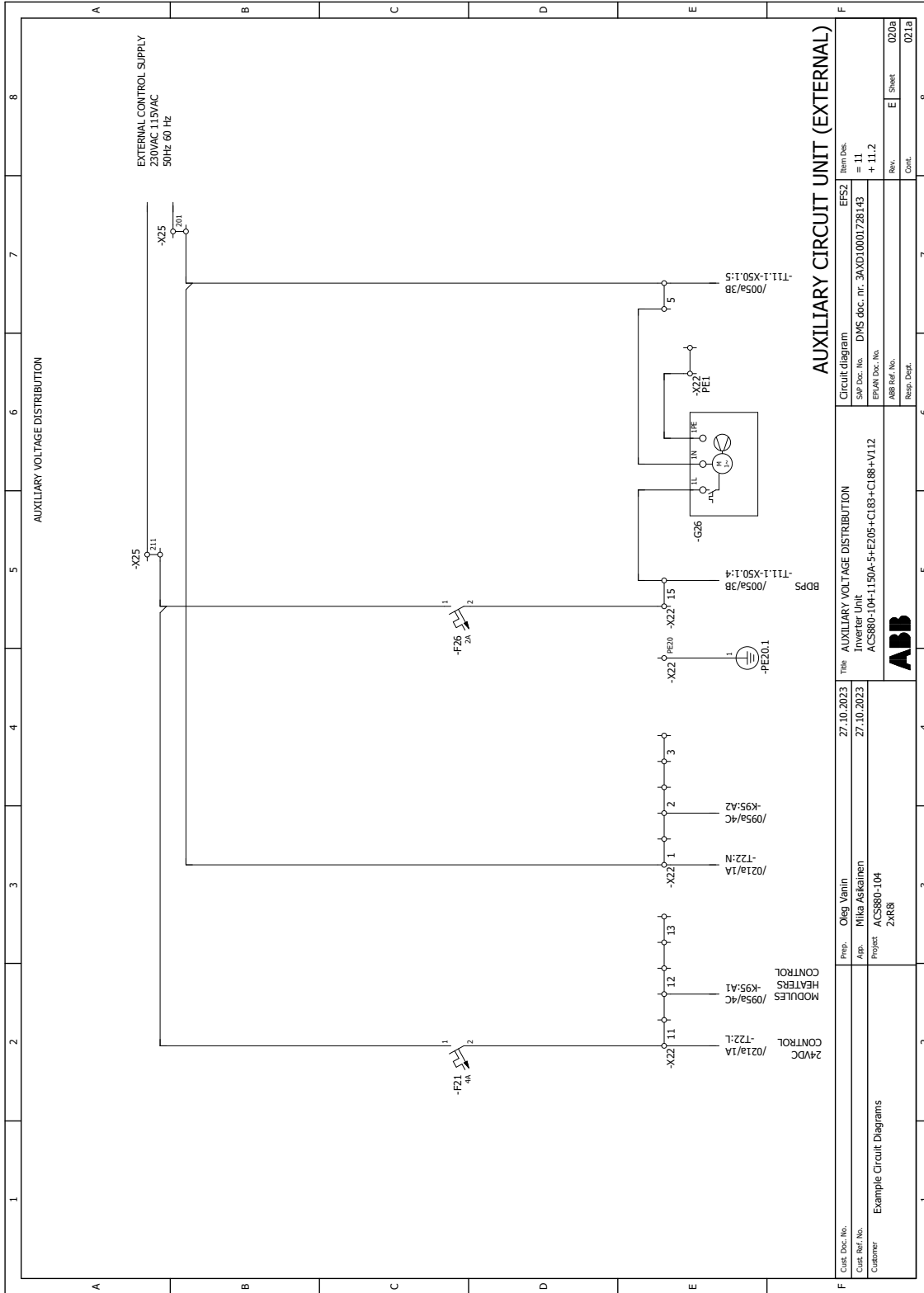

Further information

Product and service inquiries

Address any inquiries about the product to your local ABB representative, quoting the type designation and serial number of the unit in question. A listing of ABB sales, support and service contacts can be found by navigating to new.abb.com/contact-centers.

Product training

For information on ABB product training, navigate to new.abb.com/service/training.

Providing feedback on ABB manuals

Your comments on our manuals are welcome. Navigate to forms.abb.com/form-26567.

Document library on the Internet

You can find manuals and other product documents in PDF format on the Internet at www.abb.com/drives/documents.



www.abb.com/drives



3AUA0000104271P